

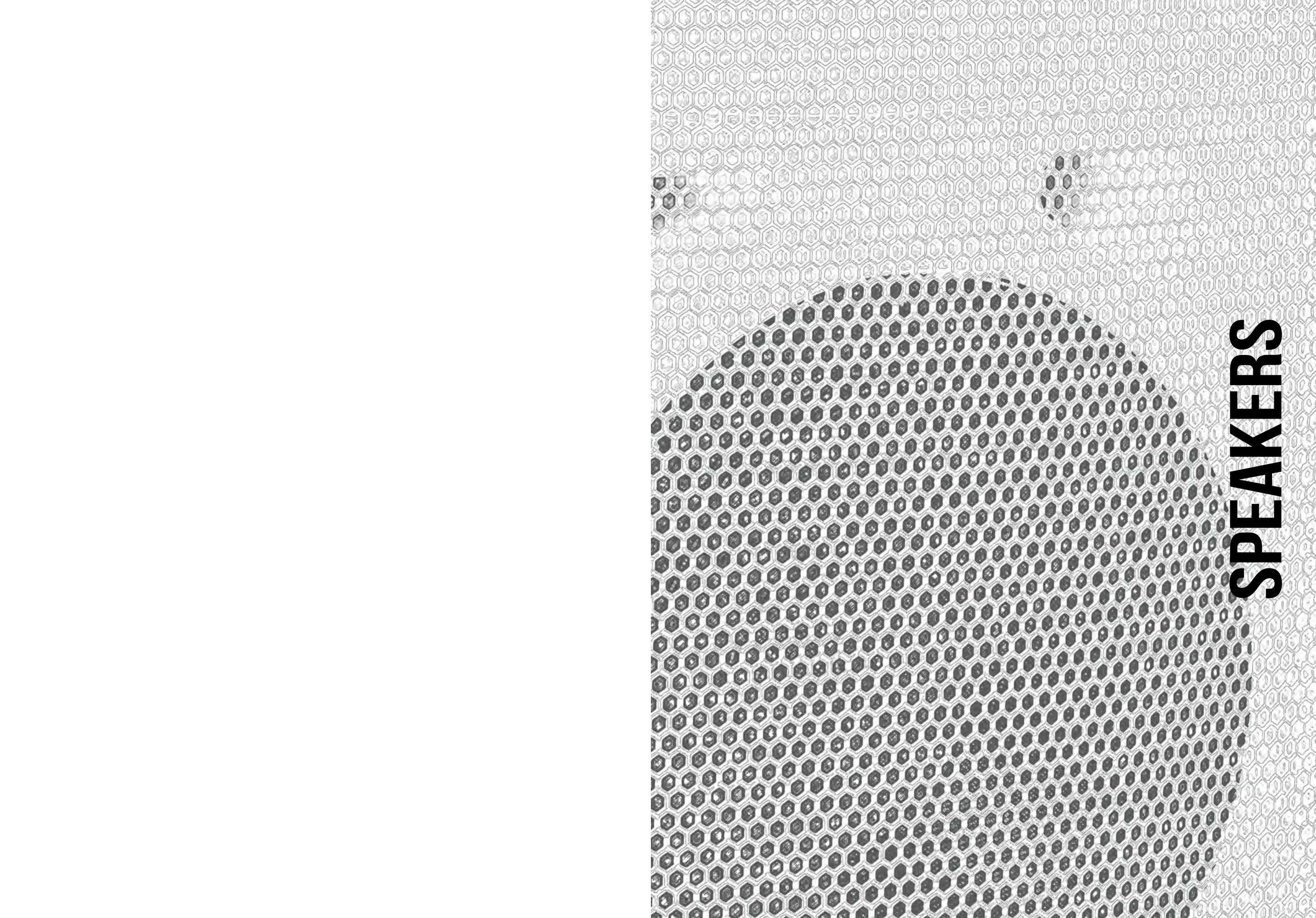

PRO AUDIO & SHOW LIGHTING
Catalog 2022



SPEAKERS

GO-SOUND Air
GO-SOUND 8AIR - 8" Battery PA System with MP3, BT VHF Mic and Go-Sound Air App Control

SoundSation Go-Sound takes another step forward and becomes Go-Sound Air. While keeping all features of the previous Go-Sound AMW series (battery or mains power, VHF wireless microphone, USB/SD-Card/BT Player, Mic/Line Inputs, 2-band graphic EQ, etc.), it allows now to control the multimedia player and the Stereo Line Input via the new "Go-Sound Air" app for both Android and iOS devices (download it from Google Play® or AppStore®).

It has never been easier to play and control your favorite playlists from your mobile phone: just connect the speaker and the App via BT to your tablet or phone and it's done deal.

As for the previous AMW Series, the battery lasts 5 hours at maximum volume and full charge. Built-in Class-D amplifiers deliver 250W peak-power (mains powered). The polypropylene enclosure is strong and lightweight, with metallic grille, 36mm standard pole mount hole, and acoustic foam to protect the woofer and give a pleasant look.

- Portable PA System with rechargeable battery
- Sturdy polypropylene enclosure yet compact and lightweight
- 250W Peak Power Class-D power amplifier (*mains powered)
- 8" woofer with 1" compression driver
- MP3 player with USB, SD Card and BT
- Go-Sound Air App Control on Android® and iOS® devices
- VHF Handheld Wireless Microphone
- Microphone/Line inputs
- 2-Band Graphic EQ
- Lithium Rechargeable Battery with up to 5-hour battery life
- 36 mm standard pole mount
- Handle on top

- Speaker Type: Portable PA System with rechargeable battery
- Frequency response: 70Hz-19KHz
- Max. SPL: 107dB (Mains Powered)
- Transducers: 8" Woofer; 1" Compression Driver
- Directivity (HxV): 90° x 40° - 60°
- Horn Type: Asymmetric
- Amplifier: 125W* Program, 250W* Peak Class-D (*Mains Powered)
- Controls: Mic/Line level, VHF Mic Level, AUX/BT/MP3 level, AUX-MP3 Switch, Master level
- 2-Band Graphic EQ: 20-100 Hz, 9K-20KHz (+/- 15dB)
- Connections: Mic/Line Combo, AUX Stereo Mini Jack, Line Out L&R RCA Jack
- LED Indicators: Power, Clip, Wireless Mic On, RF Mic, Battery Charge
- Media player: USB, SD-Card, BT, LCD Display
- Media player controls: Stop, Play/Pause, Next track, Previous track, Mode
- App Control: Auxiliary BT connection to Go-Sound Air App for Android®/iOS®
- Mains: 15VDC - 1.5A
- Add. Power (no charge function): DC12V
- Add. Power Connector: DC12V Push-in Spring Terminal
- Rechargeable Battery: 11.1V-2200mAh Lithium Battery (HKD-22 type)
- Battery Model Name: HKD-22
- Charge/Discharge Cycle: 2 hours (max. volume) / up to 5 hours (standard use)
- Battery Size (WxHxD): T19mm*W56mm*L71mm
- Wireless Mic. Frequency: VHF 175.00MHz
- Frequency Response: 40Hz - 16kHz / ±3dB
- Transmitter Power: 10mW
- Modulation Type: FM
- Continuous Using: 7 hours
- Battery Voltage: 3V (2x1.5V AA-Type Batteries)
- Hand-held Mic. Size (W/DxH): Ø33 (min) - Ø48 (max) x 265 mm
- Hand-held Mic. Net Weight: 0.218 kg (batteries included)
- Housing material: Polypropylene

J697J €158,16 £145.19

GO-SOUND Air
GO-SOUND 10AIR - 10" Battery PA System with MP3, BT VHF Mic and Go-Sound Air App Control

- Portable PA System with rechargeable battery
- Sturdy polypropylene enclosure yet compact and lightweight
- 360W Peak Power Class-D power amplifier (*mains powered)
- 10" woofer with 1" compression driver
- MP3 player with USB, SD Card and BT
- Go-Sound Air App Control on Android® and iOS® devices
- VHF Handheld Wireless Microphone
- Microphone/Line inputs
- 2-Band Graphic EQ
- Lithium Rechargeable Battery with up to 12-hour battery life
- 36 mm standard pole mount
- Trolley with 2 Wheels and 1 Telescopic Handle on top

- Speaker Type: Portable PA System with rechargeable battery
- Frequency response: 65Hz-19KHz
- Max. SPL: 109dB (Mains Powered)
- Transducers: 10" Woofer; 1" Compression Driver
- Directivity (HxV): 90° x 40° - 60°
- Horn Type: Asymmetric
- Amplifier: 180W* Program, 360W* Peak Class-D (*Mains Powered)
- Controls: Mic/Line level, VHF Mic Level, AUX/BT/MP3 level, AUX-MP3 Switch, Master level
- 2-Band Graphic EQ: 20-100 Hz, 9K-20KHz (+/- 15dB)
- Connections: Mic/Line Combo, AUX Stereo Mini Jack, Line Out L&R RCA Jack
- LED Indicators: Power, Clip, Wireless Mic On, RF Mic, Battery Charge
- Media player: USB, SD-Card, BT, LCD Display
- Media player controls: Stop, Play/Pause, Next track, Previous track, Mode
- App Control: Auxiliary BT connection to Go-Sound Air App for Android®/iOS®
- Mains: 15VDC - 1.5A
- Add. Power (no charge function): DC12V
- Add. Power Connector: DC12V Push-in Spring Terminal
- Rechargeable Battery: 12V-4500mAh Lead Battery
- Battery Model Name: 6FM4.5
- Charge/Discharge Cycle: 4-hour (max. volume) / up to 12-hour (standard use)
- Battery Size (WxHxD): T70mm*W90.5mm*L102mm
- Wireless Mic. Frequency: VHF 175.00MHz
- Frequency Response: 40Hz - 16kHz / ±3dB
- Transmitter Power: 10mW
- Modulation Type: FM
- Continuous Using: 7 hours
- Battery Voltage: 3V (2x1.5V AA-Type Batteries)
- Hand-held Mic. Size (W/DxH): Ø33 (min) - Ø48 (max) x 265 mm
- Hand-held Mic. Net Weight: 0.218 kg (batteries included)
- Housing material: Polypropylene

J698J €190,02 £174.44

Download the new **GO-SOUND Air** app
to control your Go-Sound Air





GO-SOUND 12AIR - 12" Portable PA System with Go-Sound Air App, 2 VHF Wireless Microphones, Trolley and Battery

- Portable PA System with Rechargeable Battery
- Sturdy polypropylene enclosure yet compact and lightweight
- 800W* Peak Power Class-AB power amplifier (*mains powered)
- 12" woofer with 1" compression driver
- MP3 player with USB, SD Card and BT Connection
- Go-Sound Air App Control on Android® and iOS® devices
- Dual VHF Handheld Wireless Microphone
- Microphone/Line inputs
- Echo Effect for Wireless and Mic Inputs
- 5-Band Graphic EQ
- Rechargeable Battery with 2.5 (max volume) to 4-hour (standard use) battery life
- 36 mm standard pole mount hole
- Trolley system with wheels and one telescopic handle on top + 2 side handles

- Speaker Type: Portable 2-way PA System with Rechargeable Battery and Trolley
- Frequency response: 68Hz-19KHz
- Max. SPL: 112dB (mains powered)
- LF: 12"
- HF: 1" Compression Driver (1" voice coil)
- Directivity (HxV) / Horn Type: 90° x 40° - 60° / Asymmetric
- Amplifier Power (Program/Peak): 400W* / 800W* - Class-AB (*Mains Powered)
- Controls: Mic1&2 level, Line level, Echo level, Bluetooth/MP3 level, Master level, Wireless Mics On, W. Mic1 level, W. Mic2 level
- 5-Band Graphic EQ: 100Hz, 330Hz, 1KHz, 3,3KHz, 10KHz (+/- 12dB)
- Connections: Mic 1&2 6.3mm TS Jack, Line In L&R RCA, Line Out L&R RCA
- LED Indicators: Power, Clip, Wireless Mic On, RF Mic1, RF Mic2, Battery Charge
- Media player: USB, SD-Card, BT Audio Streaming, LCD Display, Remote Control
- Media player controls: Stop, Play/Pause, Next track, Prev. track, Mode
- App Control: BT connection to Go-Sound Air App for Android®/iOS®
- Mains Power: 230VAC-50Hz
- Fuse: T1A-250V
- Mains Connector: VDE + Fuse holder
- Add. Power: External 12VDC (No charge function)
- Add. Fuse: T10A-250V
- Rechargeable Battery: 12V-7Ah Lead Battery (TC12-7.0 type)
- Add. Power Connector: 12Vcc Push-in Spring Terminal
- Battery Dimension (WxHxD): 151 x 100 x 65 mm
- Wireless MIC1 / MIC2: VHF 174.4MHz / 175 MHz
- Frequency Response: 40Hz - 16kHz / ±3dB
- Transmitter Power: 10mW
- Battery Voltage: 3V (2x1.5V AA)
- Modulation Type: FM
- Continuous Using: 7 Hours
- Hand-held Mic. Size (W/DxH): Ø33 (min) - Ø48 (max) x 265 mm
- Hand-held Mic. Net Weight: 0.218 kg (including batteries)

J699J €313,26 £287.57



GO-SOUND 15AIR - 15" Portable PA System with Go-Sound Air App, 2 VHF Wireless Microphones, Trolley and Battery

- Portable PA System with Rechargeable Battery
- Sturdy polypropylene enclosure yet compact and lightweight
- 800W* Peak Power Class-AB power amplifier (*mains powered)
- 15" woofer with 1" compression driver
- MP3 player with USB, SD Card and BT Connection
- Go-Sound Air App Control on Android® and iOS® devices
- Dual VHF Handheld Wireless Microphone
- Microphone/Line inputs
- Echo Effect for Wireless and Mic Inputs
- 5-Band Graphic EQ
- Rechargeable Battery with 2.5 (max volume) to 4-hour (standard use) battery life
- 36 mm standard pole mount hole
- Trolley system with wheels and one telescopic handle on top + 2 side handles

- Speaker Type: Portable 2-way PA System with Rechargeable Battery and Trolley
- Frequency response: 60Hz-19KHz
- Max. SPL: 114dB (mains powered)
- LF: 15"
- HF: 1" Compression Driver (1" voice coil)
- Directivity (HxV) / Horn Type: 90° x 40° - 60° / Asymmetric
- Amplifier Power (Program/Peak): 400W* / 800W* - Class-AB (*Mains Powered)
- Controls: Mic1&2 level, Line level, Echo level, Bluetooth/MP3 level, Master level, Wireless Mics On, W. Mic1 level, W. Mic2 level
- 5-Band Graphic EQ: 100Hz, 330Hz, 1KHz, 3,3KHz, 10KHz (+/- 12dB)
- Connections: Mic 1&2 6.3mm TS Jack, Line In L&R RCA, Line Out L&R RCA
- LED Indicators: Power, Clip, Wireless Mic On, RF Mic1, RF Mic2, Battery Charge
- Media player: USB, SD-Card, BT Audio Streaming, LCD Display, Remote Control
- Media player controls: Stop, Play/Pause, Next track, Prev. track, Mode
- App Control: BT connection to Go-Sound Air App for Android®/iOS®
- Mains Power: 230VAC-50Hz
- Fuse: T1A-250V
- Mains Connector: VDE + Fuse holder
- Add. Power: External 12VDC (No charge function)
- Add. Fuse: T10A-250V
- Rechargeable Battery: 12V-7Ah Lead Battery (TC12-7.0 type)
- Add. Power Connector: 12Vcc Push-in Spring Terminal
- Battery Dimension (WxHxD): 151 x 100 x 65 mm
- Wireless MIC1 / MIC2: VHF 174.4MHz / 175 MHz
- Frequency Response: 40Hz - 16kHz / ±3dB
- Transmitter Power: 10mW
- Battery Voltage: 3V (2x1.5V AA)
- Modulation Type: FM
- Continuous Using: 7 Hours
- Hand-held Mic. Size (W/DxH): Ø33 (min) - Ø48 (max) x 265 mm
- Hand-held Mic. Net Weight: 0.218 kg (including batteries)

J700J €354,11 £325.07



Download the new
GO-SOUND Air app
to control your Go-Sound Air



CHECKLINE series - High-Performance and sonic clarity

CHECKLINE Coaxial Stage Monitor Series is the answer to those rental companies, sound engineers, and bands who need robust, elegant, and handy tools on the stage, but without giving up on high-performance and sonic quality. All three models of the series offer full-range coaxial woofers. The Bi-Amp module delivers 350W (RMS)/ 1000W (Peak) power with absolute sound clarity and reliability. The internal DSP ensures maximum dynamics, overloads and overheating control, and offers 5 EQ factory presets (Full-range, Monitor, Live, Speech, DJ) and other 5 user-defined, with different equalization curves designed for all main applications. Whether they are used as monitor, full-range speaker, front fill or delayed speaker for indoor/outdoor applications with large dimensions, the CHECKLINE series is the perfect ready-to-use solution for audio professionals.

- 1.000W (Peak) Class-D bi-amped power module
- 48kHz/24-bit DSP with 5+5 EQ presets, 3-band EQ, Low-Cut, Delay (up to 100m)
- Dual-Band Peak/Overload/Thermal Limiter
- Easy-to-Use DSP Graphic Interface with LCD display and Single Encoder
- Two combo inputs (XLR/6.3 jack with MIC/LINE switches)
- Two boutique-quality microphone preamps
- Rugged, texture-painted plywood enclosure
- Sophisticated coaxial transducers
- 90°x90° sound coverage

- Coverage Pattern: 90° x 90° nominal (HxV)
- HF Horn: Coaxial (included)
- Crossover Modes: Active / DSP
- Power Rating (Continuous/Program): 350W /1.000W
- Digital Sound Processor: 48kHz/24bit
- Input Connectors: 2x XLR combo female (Mic/Line)
- Input Impedance: 9.09kohm (XLR Combo)
- Output Connectors: /
- Enclosure: 15mm, birch plywood
- Mounting: 35 mm pole socket
- Monitor Angle: 32°
- Transport: 2 integrated handles
- Finish: Black spot painting
- Grille: Powder coated, black, perforated steel with acoustic transparent foam



CHECKLINE-10A - 10" Bi-Amped Coaxial Stage Monitor with built-in DSP

- System Type: Self-powered 10" two-way, coaxial
- Frequency Range (-10 dB): 65 Hz - 20 KHz
- Frequency Response (±3 dB): 72 Hz - 20 KHz
- Crossover Frequency: 2.400 Hz
- Maximum SPL: 126 dB SPL peak
- LF Driver: 1x10"/1" coaxial transducer
- Dimensions (WxHxD): 380 x 307.3 x 410 mm
- Net Weight: 12,5 kg
- Optional Accessories: CHECKLINE-10 BAG (SKU Code J128J)

CODE	MSRP EUR	MSRP GBP
J125J	€578,65	£531.20

CHECKLINE-10 BAG

CODE	MSRP EUR	MSRP GBP
J128J	€27,42	£25.17

CHECKLINE-12A - 12" Bi-Amped Coaxial Stage Monitor with built-in DSP

- Stereo Line RCA Input
- System Type: Self-powered 12" two-way, coaxial
- Frequency Range (-10 dB): 55 Hz - 20 KHz
- Frequency Response (±3 dB): 64 Hz - 20 KHz
- Crossover Frequency: 2.300 Hz
- Maximum SPL: 127 dB SPL peak
- LF Driver: 1x12"/1" coaxial transducer
- Dimensions (WxHxD): 420 x 336.6 x 450 mm
- Net Weight: 14 kg

CODE	MSRP EUR	MSRP GBP
J126J	€602,23	£552.85

CHECKLINE-12 BAG

CODE	MSRP EUR	MSRP GBP
J129J	€31,42	£28.84

CHECKLINE-15A - 15" Bi-Amped Coaxial Stage Monitor with built-in DSP

- Stereo Line RCA Input
- System Type: Self-powered 15" two-way, coaxial
- Frequency Range (-10 dB): 50 Hz - 20 KHz
- Frequency Response (±3 dB): 59 Hz - 20 KHz
- Crossover Frequency: 2.200 Hz
- Maximum SPL: 129 dB SPL peak
- LF Driver: 1x15"/1" coaxial transducer
- Dimensions (WxHxD): 470 x 371.7 x 520 mm
- Net Weight: 18 kg
- Optional Accessories: CHECKLINE-15 BAG (SKU Code J130J)

CODE	MSRP EUR	MSRP GBP
J127J	€666,22	£611.59

CHECKLINE-15 BAG

CODE	MSRP EUR	MSRP GBP
J130J	€33,79	£31.02



VAT excluded

Hyper series

HYPER-PRO 12ACX - 12" 1600W Peak 2-way Powered Loudspeakers with DSP

The Bi-Amplified Active speakers of the HYPER-PRO ACX series are part of the high range of SOUNDSATION Pro Audio products. Peak powers of 1600 W and 1800W respectively for 12" and 15" models, selected transducers, CELESTION® compression drivers, powerful DSP: all the ingredients cleverly combined to offer the best even to the most demanding professionals. HYPER-PRO ACX series 12" and 15" woofers sound punchy and loud; the 1.4" driver lets them sound crystal clear. Sound control via the DSP is really simple. By pressing the PRESET switch you can choose between 4 audio programs (LIVE, DJ, SPEECH, MONITOR); the character of the sound will change and the corresponding LED will show the selected mode. The rear panel, organized in a very simple way and with separately controllable inputs, allows the choice of devices to be connected as a microphone, a mixer, an instrument, a CD player, a smartphone etc. In the three panel sections, input levels can quickly be set with gain controls independently of each other.

- Bi-Amped Active Speaker
- 1600W Peak Power
- Amplifier: Class-D (low-frequencies); Class-AB (high-frequencies)
- Celestion® 1.4" Compression Driver
- 4-Preset DSP (Live, DJ, Speech, Monitor)
- Balanced MIC / Line XLR input with Thru XLR output, Line Stereo input with 2x ¼ "jack, Stereo input with Mini-Jack and RCA, all with independent level controls
- Link output with Mono / Stereo selection
- Blue Front LED with On/Off Switch
- Sturdy Polypropylene Enclosure with black anti-scratch paint
- Flyable: 3 x M10 (2 on Top, 1 on Rear)
- Handles: 1 on top, 2 on sides
- Dual pole mount: Standard 36 mm, 0° and 7°

- Frequency Response: 50Hz - 20kHz / -10dB
- Max SPL: 134 dB
- Low-freq. Transducer: 12" Woofer
- High-freq. Transducer: Celestion® 1.4" Compression Driver
- Coverage: 90° x 90°
- Low-Frequency Amplifier: Class-D 350W RMS - 1400W Picco
- High-Frequency Amplifier: Class-AB 50W RMS - 200W Picco
- AC Mains: 100-120VAC/220-240VAC
- Power Consumption (Average/Peak): 800W / 1600W
- Fuse: T6.3AL 250V (100-120V) / T3.15AL250V (220-240V)
- DSP: 4 preset (Live, DJ, Speech, Monitor)
- Input Connections: 1x XLR connector, 2x 63mm Jack, 1x Mini-Jack, 1x RCA Pair
- Output Connectors: 1x XLR Thru Output (Input 1), 1x XLR Link Output with Mono/Stereo selection
- Housing Material: Polypropylene
- Grille: Steel/1.2mm
- Flyable: 3 x M10 points (2 on top, 1 on rear)
- Handles: 2 on sides; 1 on top
- Dual tripod/pole hole: Standard D36mm, 0° and 7°
- Speaker Size (WxHxD): 362 x 597 x 347 mm
- Speaker Weight: 15.5 kg



CODE	MSRP EUR	MSRP GBP
J194J	€550,42	£505.29

HYPER-PRO 15ACX - 15" 1800W Peak 2-way Powered Loudspeakers with DSP

The Bi-Amplified Active speakers of the HYPER-PRO ACX series are part of the high range of SOUNDSATION Pro Audio products. Peak powers of 1600 W and 1800W respectively for 12" and 15" models, selected transducers, CELESTION® compression drivers, powerful DSP: all the ingredients cleverly combined to offer the best even to the most demanding professionals. HYPER-PRO ACX series 12" and 15" woofers sound punchy and loud; the 1.4" driver lets them sound crystal clear. Sound control via the DSP is really simple. By pressing the PRESET switch you can choose between 4 audio programs (LIVE, DJ, SPEECH, MONITOR); the character of the sound will change and the corresponding LED will show the selected mode. The rear panel, organized in a very simple way and with separately controllable inputs, allows the choice of devices to be connected as a microphone, a mixer, an instrument, a CD player, a smartphone etc. In the three panel sections, input levels can quickly be set with gain controls independently of each other.

- Bi-Amped Active Speaker
- 1800W Peak Power
- Amplifier: Class-D (low-frequencies); Class-AB (high-frequencies)
- Celestion® 1.4" Compression Driver
- 4-Preset DSP (Live, DJ, Speech, Monitor)
- Balanced MIC / Line XLR input with Thru XLR output, Line Stereo input with 2x ¼ "jack, Stereo input with Mini-Jack and RCA, all with independent level controls
- Link output with Mono / Stereo selection
- Blue Front LED with On/Off Switch
- Sturdy Polypropylene Enclosure with black anti-scratch paint
- Flyable: 3 x M10 points (2 on top, 1 on rear)
- Handles: 1 on top, 2 on sides
- Dual pole mount: D36mm Standard, 0° and 7°

- Frequency Response: 45Hz - 20kHz / -10dB
- Max SPL: 136 dB
- Low-freq. Transducer: 15" Woofer
- High-freq. Transducer: Celestion® 1.35" Compression Driver
- Coverage: 90° x 90°
- Low-Frequency Amplifier: Class-D 400W RMS - 1600W Picco
- High-Frequency Amplifier: Class-AB 50W RMS - 200W Picco
- AC Mains: 100-120VAC/220-240VAC
- Power Consumption (Average/Peak): 900W / 1800W
- Fuse: T6.3AL 250V (100-120V) / T3.15AL250V (220-240V)
- DSP: 4 preset (Live, DJ, Speech, Monitor)
- Input Connections: 1x XLR connector, 2x ¼ " Jack, 1x ?" Mini-Jack, 1x RCA Pair
- Output Connectors: 1x XLR Thru Output (Input 1), 1x XLR Link Output with Mono/Stereo selection
- Housing Material: Polypropylene
- Grille: Steel/1.2mm
- Flyable: 3 x M10 points (2 on top, 1 on rear)
- Handles: 2 on sides; 1 on top
- Dual tripod/pole Hole: D36mm Standard, 0° and 7°
- Speaker Size (WxDxA): 445 x 376 x 698 mm
- Speaker Weight: 20.5 kg



CODE	MSRP EUR	MSRP GBP
J195J	€591,64	£543.13

Hyper series

HYPER series is the result of years of experience gathered by Soundsation in Portable Sound systems. This speaker line is built with a sturdy, lightweight and stylish polypropylene enclosure with full metal grille and acoustic foam to protect the transducers. The cutting-edge design, according to latest industry standard, offers both a great look and an optimal sound quality. All models are equipped with a Class D amp and switching power supply to deliver massive power with great efficiency and light weigh. (with the exception of the 6"). MIC and Line inputs to connect all major input sources, being microphones, mixers or media players. Featuring four M8 flying points distributed on each side, 1 handle on top and a standard D36mm pole mount hole it is ideal for both fixed installation or portable applications.

Common Features

- High resonance, sturdy and lightweight polypropylene cabinet with full metal grille and foam soundproof material
- Microphone/line inputs XLR + jack jack 1/4", stereo RCA + stereo mini jack ideal to connect smartphones or tablets
- XLR output mix out
- Volume and equalization Hi/LOW controls
- Suited for stage monitor use at 30°/45°
- Top handle for easy carrying
- 36mm pole mount
- 4 M8 flying points, one each side

HYPER TOP 6A - 200W 6" Polypropylene active speaker

- 2-Way Active Speaker
- Class AB 200W amplifier
- 6" woofer and 1" driver

- Woofer: 6" with 1.2" voice coil
- Compression driver: 1" voice coil, 1" throat
- Horn: 90° x 60°, symmetric
- Frequency Response [- 10dB]: 67Hz - 19KHz
- Frequency Response [- 3dB]: 72Hz - 19KHz
- Max SPL: 108dB
- Sensitivity: 89dB
- Class AB amplifier
- Power (Peak/Rated): 200W/100W
- Crossover: 3.5KHz, 18dB/Oct
- EQ: High (2.5KHz, +/- 12 dB); Low (150Hz, +/- 12 dB)
- LEDs: Power On (Green), Clip (Red)
- Power Requirement: 230Vac - 50 Hz
- Minimum Power Consumption: 60W
- Power Connector: VDE with T1A-250V Fuse
- Dimensions (WxHxD): 217 x 367 x 209 mm - Weight: 5,8 Kg



CODE	MSRP EUR	MSRP GBP
L474L	€201,19	£184.69



HYPER TOP 8A - 480W 8" Polypropylene bi-amped active speaker

- 2-Way bi-amped Active Speaker
- 2 Class D amplifiers 480W (432W+48W)
- 8" woofer and 1" driver

- Woofer: 8" with 1.5" voice coil
- Compression driver: 1" voice coil, 1" throat
- Horn: 90° x 60°, symmetric
- Frequency Response [- 10dB]: 56Hz - 19KHz
- Frequency Response [- 3dB]: 61Hz - 19KHz
- Max SPL: 111dB
- Sensitivity: 91dB
- 2 x Class D amplifier
- Power (Peak/Rated): 480W (432+48W) / 240W (216+24W)
- Crossover: 3.5KHz, 24dB/Oct.
- EQ: High (2.5KHz, +/- 12 dB); Low (150Hz, +/- 12 dB)
- LEDs: Power On (Green), Clip (Red)
- Power Requirement: 230Vac - 50 Hz
- Minimum Power Consumption: 120W
- Power Connector: VDE with T2A-250V Fuse
- Dimensions (WxHxD): 270 x 495 x 270 mm - Weight: 7,2 Kg



CODE	MSRP EUR	MSRP GBP
L475L	€234,52	£215.29



Accessories

CODE	DESCRIPTION	MSRP EUR	MSRP GBP
E867E	HYPER TOP 6 COVER - HYPER TOP 6 Active/Passive Padded Cover	€21,79	£20.00
E868E	HYPER TOP 8 COVER - HYPER TOP 8 Active/Passive Padded Cover	€28,12	£25.81
E872E	ESTRO 6P BRACKET - Wall-Mount Bracket for ESTRO 6P and HYPER TOP 6 Active/Passive	€40,16	£36.87
E873E	ESTRO 8P BRACKET - Wall-Mount Bracket for ESTRO 8P and HYPER TOP 8 Active/Passive	€45,08	£41.38



HYPER TOP 10A - 500W 10" Polypropylene bi-amped active speaker

- 2-Way bi-amped Active Speaker
- 2 Class D amplifiers 500W (440W+60W)
- 10" woofer and 1" driver

- Woofer: 10" with 2" voice coil
- Compression driver: 1" voice coil, 1" throat
- Horn: 90° x 60°, symmetric
- Frequency Response [- 10dB]: 53Hz - 19KHz
- Frequency Response [- 3dB]: 58Hz - 19KHz
- Max SPL: 116dB
- Sensitivity: 93dB
- 2 x Class D amplifier
- Power (Peak/Rated): 500W (440+60W) / 250W (220+30W)
- Crossover: 3.2KHz, 24dB/Oct.
- EQ: High (2.5KHz, +/- 12 dB); Low (150Hz, +/- 12 dB)
- LEDs: Power On (Green), Clip (Red)
- Power Requirement: 230Vac - 50 Hz
- Minimum Power Consumption: 125W
- Power Connector: VDE with T2A-250V Fuse
- Dimensions (WxHxD): 300 x 528 x 306 mm
- Weight: 9 Kg

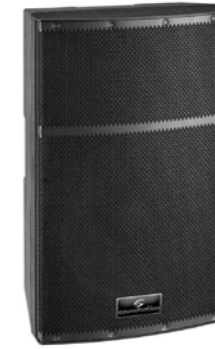

CODE	MSRP EUR	MSRP GBP
L476L	€292,06	£268.11

HYPER TOP 10 COVER - HYPER TOP 10 Active/Passive Padded Cover

CODE	MSRP EUR	MSRP GBP
E869E	€32,08	£29.45



ESTRO 10P BRACKET - Wall-Mount Bracket for ESTRO 10P and HYPER TOP 10 Active/Passive

CODE	MSRP EUR	MSRP GBP
E874E	€56,56	£51.92





HYPER TOP 12A - 1000W 12" Polypropylene bi-amped active speaker

- 2-Way bi-amped Active Speaker
- Class D amplifier for Low-frequencies; Class-AB for High-frequencies. 1000W total power (800W+200W)
- 12" woofer and 1.35" driver
- Woofer: 12" with 2.5" voice coil
- Compression driver: 1.35" voice coil, 1" throat
- Horn: 90° x 60°, symmetric
- Frequency Response [- 10dB]: 48Hz - 19KHz
- Frequency Response [- 3dB]: 53Hz - 19KHz
- Max SPL: 119dB
- Sensitivity: 95dB
- Amplifiers: Class-D (Low freq.); Class-AB (High Freq.)
- Power (Peak/Rated): 1000W (800+200W) / 500W (400+100W)
- Crossover: 2.8KHz, 24dB/Oct.
- EQ: High (2.5KHz, +/- 12 dB); Low (150Hz, +/- 12 dB)
- LEDs: Power On (Green), Clip (Red)
- Power Requirement: 230Vac - 50 Hz
- Minimum Power Consumption: 250W
- Power Connector: VDE with T2A-250V Fuse
- Dimensions (WxHxD): 355 x 611 x 350 mm
- Weight: 14,6 Kg



HYPER TOP 12 COVER
HYPER TOP 12 Active/Passive/Pro Padded Cover

CODE	MSRP EUR	MSRP GBP
L477L	€347,17	£318.70

CODE	MSRP EUR	MSRP GBP
E870E	€42,37	£38.90



HYPER TOP 15A - 1000W 15" Polypropylene bi-amped active speaker

- 2-Way bi-amped Active Speaker
- Class D amplifier for Low-frequencies; Class-AB for High-frequencies. 1000W total power (800W+200W)
- 15" woofer and 1.35" driver
- Woofer: 15" with 3" voice coil
- Compression driver: 1.35" voice coil, 1" throat
- Horn: 90° x 60°, symmetric
- Frequency Response [- 10dB]: 41Hz - 19KHz
- Frequency Response [- 3dB]: 46Hz - 19KHz
- Max SPL: 121dB
- Sensitivity: 96dB
- Amplifiers: Class-D (Low freq.); Class-AB (High Freq.)
- Power (Peak/Rated): 1000W (800+200W) / 500W (400+100W)
- Crossover: 2.6KHz, 24dB/Oct.
- EQ: High (2.5KHz, +/- 12 dB); Low (150Hz, +/- 12 dB)
- LEDs: Power On (Green), Clip (Red)
- Power Requirement: 230Vac - 50 Hz
- Minimum Power Consumption: 250W
- Power Connector: VDE with T2A-250V Fuse
- Dimensions (WxHxD): 420 x 697 x 383 mm
- Weight: 18 Kg



CODE	MSRP EUR	MSRP GBP
L478L	€381,61	£350.32

HYPER TOP 15 COVER
HYPER TOP 15 Active/Passive/Pro Padded Cover

CODE	MSRP EUR	MSRP GBP
E871E	€46,70	£42.87



GO-SOUND series

Go-Sound series is built with the user in mind. As result of years of experience gathered by Soundsation in portable sound systems, we designed these versatile high-quality speakers with unmatched value and performances. Built in a polypropylene cabinet, sturdy yet compact and lightweight, these active speaker are equipped with Class AB amplifiers, which guarantee reliability and outstanding performances. Mic and line inputs are included to allow the user to connect various audio sources such as microphones, mixers as well as smartphones and tablets. Go-Sound series is an incredible value and the perfect solution in many situations such as parties, presentations, schools, conference and live music, delivering great sound quality, reliability and ease of use.

Common Features

- 2-Way Active Speaker
- Sturdy polypropylene enclosure yet compact and lightweight
- Balanced microphone/Line inputs XLR + 1/4" Jack and line inputs Stereo RCA + Stereo Mini jack ideal to connect smartphones and tablets
- XLR line output
- Mic/line switch, volume and equalizer (Hi and Low) controls
- 36 mm standard pole mount
- 2 side handles for convenient carrying

GO-SOUND 8A - 320 Watt 8" Polypropylene Active Speaker

- 320 Watt class AB power amplifier
- 8" woofer with 1" compression driver
- Woofer: 8" with 1.2" voice coil
- Compression driver: 1" voice coil, 1" throat
- Directivity: 90° x 50°, asymmetric
- Frequency Response [- 3dB]: 80Hz - 18KHz
- Frequency Response [- 10dB]: 75Hz - 18KHz
- Max SPL(Peak): 110dB - Sensitivity: 91dB
- Power (Peak/Rated): 320W/160W
- Crossover: 3.5KHz, 18dB/Oct.
- EQ: High (2.5KHz, +/- 12 dB); Low (150Hz, +/- 12 dB)
- LEDs: Power On (Green), Clip (Red)
- Power Requirement: 230Vac - 50 Hz
- Minimum Power Consumption: 90W
- Power Connector: VDE with T1A-250V Fuse
- Speaker Dimension (WxHxD): 260 x 390 x 250 mm - Weight: 5 Kg



CODE	MSRP EUR	MSRP GBP
L479L	€144,13	£132.31

GO-SOUND 12A - 880 Watt 12" Polypropylene Active Speaker

- 880 Watt class AB power amplifier
- 12" woofer with 1.35" compression driver
- Woofer: 12" with 2" voice coil
- Compression driver: 1.35" voice coil, 1" throat
- Directivity: 90° x 50°, asymmetric
- Frequency Response [- 3dB]: 60Hz - 18KHz
- Frequency Response [- 10dB]: 55Hz - 18KHz
- Max SPL(Peak): 114dB - Sensitivity: 94dB
- Power (Peak/Rated): 880W/440W
- Crossover: 3KHz, 24dB/Oct.
- EQ: High (2.5KHz, +/- 12 dB); Low (150Hz, +/- 12 dB)
- LEDs: Power On (Green), Clip (Red)
- Power Requirement: 230Vac - 50 Hz
- Minimum Power Consumption: 230W
- Power Connector: VDE with T3.15A-250V Fuse
- Speaker Dimension (WxHxD): 375 x 588 x 320 mm - Weight: 12,2 Kg



CODE	MSRP EUR	MSRP GBP
L481L	€256,56	£235.52

GO-SOUND 10A - 480 Watt 10" Polypropylene Active Speaker

- 480 Watt class AB power amplifier
- 10" woofer with 1" compression driver
- Woofer: 10" with 1.5" voice coil
- Compression driver: 1" voice coil, 1" throat
- Directivity: 90° x 50°, asymmetric
- Frequency Response [- 3dB]: 75Hz - 18KHz
- Frequency Response [- 10dB]: 70Hz - 18KHz
- Max SPL(Peak): 112 dB - Sensitivity: 93dB
- Power (Peak/Rated): 480W/240W
- Crossover: 3.2KHz, 18dB/Oct.
- EQ: High (2.5KHz, +/- 12 dB); Low (150Hz, +/- 12 dB)
- LEDs: Power On (Green), Clip (Red)
- Power Requirement: 230Vac - 50 Hz
- Minimum Power Consumption: 130W
- Power Connector: VDE with T1A-250V Fuse
- Speaker Dimension (WxHxD): 320 x 490 x 260 mm - Weight: 6,4 Kg



CODE	MSRP EUR	MSRP GBP
L480L	€197,94	£181.71

GO-SOUND 15A - 880 Watt 15" Polypropylene Active Speaker

- 880 Watt class AB power amplifier
- 15" woofer with 1.35" compression driver
- Woofer: 15" with 2.5" voice coil
- Compression driver: 1.35" voice coil, 1" throat
- Directivity: 90° x 50°, asymmetric
- Frequency Response [- 3dB]: 55Hz - 18KHz
- Frequency Response [- 10dB]: 50Hz - 18KHz
- Max SPL(Peak): 116dB - Sensitivity: 95dB
- Power (Peak/Rated): 880W/440W
- Crossover: 2.7KHz, 24dB/Oct.
- EQ: High (2.5KHz, +/- 12 dB); Low (150Hz, +/- 12 dB)
- LEDs: Power On (Green), Clip (Red)
- Power Requirement: 230Vac - 50 Hz
- Minimum Power Consumption: 230W
- Power Connector: VDE with T3.15A-250V Fuse
- Speaker Dimension (WxHxD): 440 x 703 x 370 mm - Weight: 15 Kg



CODE	MSRP EUR	MSRP GBP
L482L	€288,04	£264.42

GO-SOUND 12AM - 880 Watt 12" Polypropylene Active Speaker with MP3/ Bluetooth™ player

- 880 Watt class AB power amplifier
- 12" woofer with 1.35" compression driver
- Large LCD display MP3 player with USB/SD input and Bluetooth™ and to play your favourites tunes
- Balanced Microphone/Line inputs XLR + 1/4" Jack, line inputs Stereo RCA + XLR, line input stereo Mini jack ideal to connect smartphones and tablets
- XLR line output
- Mic/line switch, volume and equalizer (Hi and Low) controls
- 2-Way active speaker
- Woofer: 12" with 2" voice coil
- Compression driver: 1.35" voice coil, 1" throat
- Directivity: 90° x 50°, asymmetric
- Frequency Response [- 3dB]: 60Hz - 18KHz
- Frequency Response [- 10dB]: 55Hz - 18KHz
- Max SPL(Peak): 114dB
- Sensitivity: 94dB
- Power (Peak/Rated): 880W/440W
- Crossover: 3KHz, 24dB/Oct.
- EQ: High (2.5KHz, +/- 12 dB); Low (150Hz, +/- 12 dB)
- USB/SD input: compatible with memory stick/sd card up to 32 GB
- Media player formats: MP3 fino a 320kBs e Wav 16 bit 44.1 kHz
- LEDs: Power On (Green), Clip (Red)
- Power Requirement: 230Vac - 50 Hz
- Minimum Power Consumption: 230W
- Power Connector: VDE with T3.15A-250V Fuse
- Speaker Dimension (WxHxD): 375 x 588 x 320 mm
- Weight: 12,2 Kg



CODE	MSRP EUR	MSRP GBP
L483L	€297,08	£272.72

GO-SOUND 15AM - 880 Watt 15" Polypropylene Active Speaker with MP3/ Bluetooth™ player

- 880 Watt class AB power amplifier
- 15" woofer with 1.35" compression driver
- 2-Way active speaker
- Woofer: 15" with 2.5" voice coil
- Compression driver: 1.35" voice coil, 1" throat
- Directivity: 90° x 50°, asymmetric
- Frequency Response [- 3dB]: 55Hz - 18KHz
- Frequency Response [- 10dB]: 50Hz - 18KHz
- Max SPL(Peak): 116dB
- Sensitivity: 95dB
- Power (Peak/Rated): 880W/440W
- Crossover: 2.7KHz, 24dB/Oct.
- EQ: High (2.5KHz, +/- 12 dB); Low (150Hz, +/- 12 dB)
- USB/SD input: compatible with memory stick/sd card up to 32 GB
- Media player formats: MP3 fino a 320kBs e Wav 16 bit 44.1 kHz
- LEDs: Power On (Green), Clip (Red)
- Power Requirement: 230Vac - 50 Hz
- Minimum Power Consumption: 230W
- Power Connector: VDE with T3.15A-250V Fuse
- Speaker Dimension (WxHxD): 440 x 703 x 370 mm
- Weight: 15 Kg



CODE	MSRP EUR	MSRP GBP
L484L	€334,72	£307.27

PASSIVE SPEAKERS

LIVEMAKER 6P - Pair of 6" 2-Way Passive Speakers

LIVEMAKER 6P are passive 2-way loudspeakers designed for small portable applications. The custom 6" woofer and 1" compression driver with titanium diaphragm ensure warm, crystal clear sound with 90° horizontal and 60° vertical angular coverage. There is a practical handle on rear side and a 36mm pole or tripod adapter on the bottom.

- 2-way speakers with front bass reflex
- 6" woofer, 1" titanium driver
- 75W RMS
- Speakon 4P connection
- Reinforced MDF cabinet
- 36mm pole / tripod hole

- Speaker Type: 2-Way Passive
- RMS Power: 75W
- Impedance: 8 ohm
- Frequency Response [- 10dB]: 85Hz-18kHz
- Sensitivity (1W@1m): 93dB
- Max SPL (Peak): 116dB
- HF Type: 1" Compr. Driver (1" v.c.)
- Diaphragm material: Titanium
- HF Horn (HxV): 90° x 60° Symmetric
- Crossover Frequency: 3.5kHz (12dB/Oct.)
- Woofer Diameter: 6.5" (167mm), 1.5" v.c.
- Input Connector: Speakon
- Housing: MDF
- Grille material and thickness: Steel, 1.5mm
- Finish: Anti-scratch Black Painting
- Handles: 1 on rear side
- Pole Mount: 36mm
- Speaker Dimension - Single (WxDxH): 204 x 190 x 370 mm
- Net Weight - Single : 6, 5 kg



R746R	€203,94	£187.22
-------	---------	---------



Hyper series

Common Features

- Bass-reflex Active Subwoofer
- Integrated active crossover
- XLR L/R Balanced Line Inputs
- XLR L/R Balanced Filtered Outputs, XLR L/R Balanced Link Outputs
- Controls: Sub Level, 80-120Hz crossover switch, 0-180° Phase, Shape

- switch, Ground Lift On-Off
- RMS, Overload, Thermal limiter protection
- Multiplex Birch plywood enclosure with painted black finish
- 2 lateral recessed handles
- M20 type speaker pole mount to reduce vibrations

HYPER BASS 12A - 900 Watt Bass reflex active subwoofer



- 12" woofer
- 900 Watt class D amplifier

- Woofer: 12", 3" voice coil
- Amplifier: 900W Peak/ 450W RMS, Class-D
- Max SPL(Peak): 120dB
- Crossover Frequency: 120 Hz (24dB/Oct.)
- Frequency Response [- 10dB]: From 40 Hz to 150 Hz
- Frequency Response [- 3dB]: From 50 Hz to 120 Hz
- LEDs: Power On (Green), Signal (Green) / Limit (Red)
- Power Requirement: 230Vac - 50 Hz
- Minimum Power Consumption: 500W
- Power Connector: VDE with T5AL-250V Fuse
- Dimensions (LxHxW): 480 x 480 x 560 mm - Weight: 17 Kg

CODE	MSRP EUR	MSRP GBP
L485L	€556,58	£510.94

HYPER BASS 15A - 1200 Watt 15" Bass reflex active subwoofer



- 15" woofer
- 1200 Watt class D amplifier
- Predisposition for 4 wheels (not included)

- Woofer: 15", 4" voice coil
- Amplifier: 1200W Peak/ 600W RMS, Class-D
- Max SPL(Peak): 124dB
- Crossover Frequency: 120 Hz (24dB/Oct.)
- Frequency Response [- 10dB]: From 35 Hz to 150 Hz
- Frequency Response [- 3dB]: From 40 Hz to 120 Hz
- LEDs: Power On (Green), Signal (Green) / Limit (Red)
- Power Requirement: 230Vac - 50 Hz
- Minimum Power Consumption: 750W
- Power Connector: VDE with T5AL-250V Fuse
- Dimensions (LxHxW): 520 x 670 x 625 mm - Weight: 29 Kg

CODE	MSRP EUR	MSRP GBP
L486L	€630,80	£579.07

HYPER BASS 18A - 1200 Watt 18" Bass reflex active subwoofer



- 18" woofer
- 1200 Watt class D amplifier
- Predisposition for 4 wheels (not included)

- Woofer: 18", 4" voice coil
- Amplifier: 1200W Peak/ 600W RMS, Class-D
- Max SPL(Peak): 126dB
- Crossover Frequency: 120 Hz (24dB/Oct.)
- Frequency Response [- 10dB]: From 30 Hz to 150 Hz
- Frequency Response [- 3dB]: From 35 Hz to 120 Hz
- LEDs: Power On (Green), Signal (Green) / Limit (Red)
- Power Requirement: 230Vac - 50 Hz
- Minimum Power Consumption: 750W
- Power Connector: VDE with T5AL-250V Fuse
- Dimensions (LxHxW): 620 x 700x 740 mm - Weight: 37 Kg

CODE	MSRP EUR	MSRP GBP
L487L	€705,00	£647.19



HYPER WHEEL - 75mm High-Load Wheel with Roller Bearing

- 75mm High-Load Wheel with Roller Bearing for SOUNDSATION HYPER BASS 15 & 18 Active/Passive Subwoofers. Working Load 200kg (each wheel). Maximum load per 4pcs set: 800 kg.

CODE	MSRP EUR	MSRP GBP
E875E	€13,57	£12.46



HYPER WHEEL BRAKE - 75mm High-Load Wheel with Roller Bearing and Brake

- 75mm High-Load Wheel with Roller Bearing and Brake for SOUNDSATION HYPER BASS 15 & 18 Active/Passive Subwoofers. Working Load 200kg (each wheel). Maximum load per 4pcs set: 800 kg.

CODE	MSRP EUR	MSRP GBP
E876E	€17,34	£15.92

Hyper series

Common Features

- Sturdy housing in plywood with front bass-reflex
- Anti-scratch powder coating
- Connection: Spekon Input and Output (+1 Positive, -1 Negative)
- Recessed handles (1 per side)
- Pole mounting with M20 thread

- Input Connectors: 1x2 Poles Speakon connector
- Output Connectors: 1x2 Poles Speakon connector
- Housing Material: Plywood
- Grille Material: Steel
- Thickness Grille: 1.5mm
- Handles: 2 Recessed handles (1 on each side)
- Pole Mount: SUBEST100-BK or SUBST100-M20 (Optional)

HYPER BASS 12P - 12" Bass-Reflex Professional Passive Subwoofer



- 12" custom woofer with 3" voice coil
- Power: 500W RMS - 8ohm (1000W Program / 2000W Peak)
- Frequency Resp. (-10 dB): 40Hz - 1KHz
- Frequency Resp. (-3 dB): 50Hz - 600Hz
- Sensitivity (1m @ 1m): 94dB
- MAX SPL: 124dB
- RMS Power: 500W
- Peak Power: 2000W
- Impedance: 8 Ohm
- LF Diameter: 12"
- LF Voice Coil: 3"
- Subwoofer Dimensions (WxHxD): 420 x 500x 475 mm
- Subwoofer Weight: 23,5 kg

CODE	MSRP EUR	MSRP GBP
E578E	€373,05	£342.46

HYPER BASS 18P - 18" Bass-Reflex Professional Passive Subwoofer

- 18" custom woofer with 4" voice coil
- Power: 800W RMS - 8ohm (1600W Program / 3200W Peak)
- Frequency Resp. (-10 dB): 35Hz - 1KHz
- Frequency Resp. (-3 dB): 40Hz - 600Hz
- Sensibility (1W @ 1m): 98dB
- MAX SPL: 130dB
- RMS Power: 800W
- Program/Peak Power: 1600/3200W
- Impedance: 8 Ohm
- LF Diameter: 18"
- LF Voice Coil: 4"
- Subwoofer Dimensions (WxHxD): 540 x 660 x 620 mm
- Subwoofer Weight: 38,7 kg

CODE	MSRP EUR	MSRP GBP
E580E	€484,98	£445.21

HYPER BASS 15P - 15" Bass-Reflex Professional Passive Subwoofer



- 15" custom woofer with 4" voice coil
- Power: 600W RMS - 8ohm (1200W Program / 2400W Peak)
- Frequency Resp. (-10 dB): 35Hz - 1KHz
- Frequency Resp. (-3 dB): 45Hz - 600Hz
- Sensitivity (1W @ 1m): 96dB
- MAX SPL: 127dB
- RMS Power: 600W
- Program/Peak Power: 1200/2400W
- Impedance: 8 Ohm
- LF Diameter: 15"
- LF Voice Coil: 4"
- Subwoofer Dimensions (WxHxD): 460 x 610 x 565 mm
- Subwoofer Weight: 32,5 kg

CODE	MSRP EUR	MSRP GBP
E579E	€447,66	£410.95



SPWM Series

SPWM-05V - 100 Volt passive speaker pair with 5" woofer and wall mount stand included

Soundsation SPWM series represent a reliable and versatile solutions for your sound amplification needs. Polypropylene cabinet, compared to wood ones, is much lighter and also offers great performances both in terms of resistance and sound quality. SPWM-05V is suited in many applications. Working with 100V power supply and coming with a wall mount stand, it's suitable in fixed installations: schools, conferences, pubs, restaurants, home studios, small concerts or events. The versatile and reliable solution for your amplification needs.

- 2 way full range passive speaker pair
- Polypropylene cabinet
- Max Power: 50W per speaker, total 100W
- 5" speaker + 3/4" dome tweeter
- Speaker impedance 8Ohm
- 100V power supply
- Possibility to install several speakers according to the power amplifier
- Input binding post connectors
- Wall mount stand included with security cable

- Maximum power handling: 50W per speaker
- Woofer dimension: 5" (12,7 Cm)
- Tweeter dimension: dome 3/4" (1,905 Cm)
- Frequency response: 95Hz-20kHz
- Maximum SPL: 106dB
- Sensitivity(1m/1W): 88dB
- Crossover Frequency: 4kHz
- Impedence: 8Ohm
- Power supply: 100V
- Color: glossy black
- Dimensions: (HxWxL): 226x152x130 mm
- Weight: 3,2 Kg



CODE	MODEL	COLOR	MSRP EUR	MSRP GBP
I573I	SPWM-05V	Glossy Black	€140,84	£129.29
I574I	SPWM-05V-WH	Glossy White	€147,32	£135.24

WSS-10B - Wall mount black speaker stand with omniball system

- Fully built in metal material
- Two speaker fixing points
- 4 wall fixing point (screws not included)
- Omniball system for 180° horizontal adjustment in all directions
- Load capacity: 18 Kg
- Directivity: 180° in all directions
- Horizontal distance of wall fixing holes: 79 mm
- Vertical distance of wall fixing holes: 81 mm
- Distance of speaker fixing holes : 60mm +/-6mm
- Wall plate dimension (LxH): 99 x 99 mm
- Speaker plate dimension (LxH): 80 x 40mm
- Total lenght: 120 mm - Weight: 0,7 Kg



CODE	MODEL	COLOR	MSRP EUR	MSRP GBP
D865D	WSS-10B	Black	€11,96	£10.98
D866D	WSS-10W	White	€11,96	£10.98

STUDIOPAD5 - Pair of foam pads for 5" Studio Monitors

- Ideal for acoustic decoupling of studio monitors
- 2 different angles (in addition to 0°): 3.3°, 7.1°
- Load-bearing capacity per pad: 12 kg
- Anthracite
- Dimension (WxDxH): 180x300x40mm
- Package consist of 2 Pads

CODE	MSRP EUR	MSRP GBP
J404J	€9,61	£8.82



STUDIOPAD8 - Pair of foam pads for 8" Studio Monitors

- Ideal for acoustic decoupling of studio monitors
- 2 different angles (in addition to 0°): 2.6°, 5.1°
- Load-bearing capacity per pad: 18 kg
- Anthracite
- Dimension (WxDxH): 260x370x40mm
- Package consist of 2 Pads

CODE	MSRP EUR	MSRP GBP
J408J	€17,19	£15.78

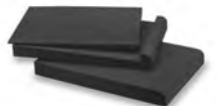

STUDIOPAD6 - Pair of foam pads for 6.5" Studio Monitors

- Ideal for acoustic decoupling of studio monitors
- 2 different angles (in addition to 0°): 3.2°, 6.5°
- Load-bearing capacity per pad: 15 kg
- Anthracite
- Dimension (WxDxH): 230x330x40mm
- Package consist of 2 Pads

CODE	MSRP EUR	MSRP GBP
J407J	€14,47	£13.28



CLARITY A5 - Bi-amplified 2-way white studio monitor with 5,25" Woofer

The CLARITY A5-W studio monitor is part of the new CLARITY Studio Monitor series and is an optimal solution for both home recording and the Studio. The technological implementation makes these Monitors ideal for high-level listening thanks to the linear frequency response and the possibility of adjustment for high and low frequencies. The wide choice of inputs positioned on the rear panel (XLR, TRS, RCA) guarantees ease of use. The modern and refined design and the satin white finish make this studio monitor elegant and suitable for many environments.

- Biamp two ways active speaker
- 50W RMS output power Woofer
- 30W RMS output power Tweeter
- 50Hz-22KHz Frequency response at -10dB
- 5,25" Woofer
- 1,0" Tweeter Silk Dome
- Attenuation of High Frequencies (-2/-1/0/+1dB above 2KHz)
- Attenuation of Low Frequencies (-2/-1/0/+2dB below 100Hz)
- Balanced 1/4" TS / XLR and unbalanced RCA inputs
- Rugged MDF Case

- Speaker Type: Biamp two ways active speaker
- Mains Power: 220-240V~/50-60Hz
- Fuse: T5AL250V
- Frequency response (-10dB): 50Hz- 22KHz
- Woofer: 5,25" (Paper Cone)
- Tweeter: 1,0" (Silk Dome)
- Crossover: 2,5KHz
- Woofer Output Power: 50W RMS
- Tweeter Output Power: 30W RMS
- SPL (1m axial direction): 108dB
- Audio Input Connections: Balanced type 1/4"/ XLR interface,unbalanced RCA
- High Frequency Adjustment: -2/-1/0/+1dB above 2KHz
- Low Frequency Adjustment: -2/-1/0/+2dB below 100Hz
- Cabinet Material: MDF
- Dimensions(WxDxH): 175 x 220 x 285 mm
- Weight: 5,6Kg



CODE	MODEL	COLOR	MSRP EUR	MSRP GBP
L866L	CLARITY A5	Black	€160,54	£147.38
L869L	CLARITY A5-W	White	€160,54	£147.38

CLARITY A6- Bi-amplified 2-way studio monitor with 6,5" Woofer

The CLARITY A6 studio monitor is part of the new CLARITY Studio Monitor series and is an optimal solution for both home recording and the Studio. The technological implementation makes these Monitors ideal for high-level listening thanks to the linear frequency response and the possibility of adjustment for high and low frequencies. The wide choice of inputs positioned on the rear panel (XLR, TRS, RCA) guarantees ease of use. The modern and refined design and the satin black finish make this studio monitor elegant and suitable for many environments.

- Biamp two ways active speaker
- 60W RMS output power Woofer
- 30W RMS output power Tweeter
- 45Hz - 22KHz Frequency Response at -10dB
- 6,5" Woofer
- 1,0" Tweeter Silk Dome
- Attenuation of High Frequencies (-2/-1/0/+1dB above 2KHz)
- Attenuation of Low Frequencies (-2/-1/0/+2dB below 100Hz)
- Balanced 1/4" TS / XLR and unbalanced RCA inputs
- Rugged MDF Case

- Speaker Type: Biamp two ways active speaker
- Mains Power: 220-240V~/50-60Hz
- Fuse: T5AL250V
- Frequency response (-10dB): 45Hz- 22KHz
- Woofer: 6,5" (Paper Cone)
- Tweeter: 1,0" (Silk Dome)
- Crossover: 2,5KHz
- Woofer Output Power: 60W RMS
- Tweeter Output Power: 30W RMS
- SPL (1m axial direction): 111dB
- Audio Input Connections: Balanced type 1/4"/ XLR interface,unbalanced RCA
- High Frequency Adjustment: -2/-1/0/+1dB above 2KHz
- Low Frequency Adjustment: -2/-1/0/+2dB below 100Hz
- Cabinet Material: MDF
- Dimensions(WxDxH): 224 x 253 x 350 mm - Weight: 7,4Kg



CODE	MODEL	COLOR	MSRP EUR	MSRP GBP
L867L	CLARITY A6	Black	€170,55	£156.56
L870L	CLARITY A6-W	White	€170,55	£156.56

CLARITY S-10- Active Studio Subwoofer with 10" Woofer

The 10" CLARITY S-10 active studio subwoofer has been designed to offer musicians, sound technicians and music producers a deep and dynamic response at low frequencies and therefore precise and clear bass in the sound for a full musical experience with 350 watts of class AB amplification. The wide choice of inputs positioned on the rear panel (XLR, TRS, RCA) guarantees ease of use. The modern and refined design and the satin black finish make this studio subwoofer elegant and suitable for many environments.

- Active Subwoofer
- 350W RMS output power
- AB Class Amplifier
- 30Hz - 150Hz Frequency response at -10dB
- 10" Woofer
- Attenuation adjustment of High and Low Frequencies (from 80Hz to 120Hz)
- Balanced 1/4" TS / XLR and unbalanced RCA inputs
- Rugged MDF Case

- Speaker Type: Active Subwoofer
- Mains Power: 220-240V~/50-60Hz
- Fuse: T5AL250V
- Frequency Response: (-10dB) 30Hz - 150Hz
- Woofer: 10" (Paper Cone)
- Woofer Output Power: 350W RM
- Amplifier Class: AB
- SPL (1m axial direction) 118dB
- Audio Input Connections: Balanced type 1/4"TS/ XLR interface,unbalanced RCA
- Cabinet Material: MDF
- Dimensions(WxDxH): 300 x 320 x 300 mm - Weight: 12,8Kg

CODE	MODEL	COLOR	MSRP EUR	MSRP GBP
L868L	CLARITY S-10	Black	€315,15	£289.31
L871L	CLARITY S-10-W	White	€315,15	£289.31



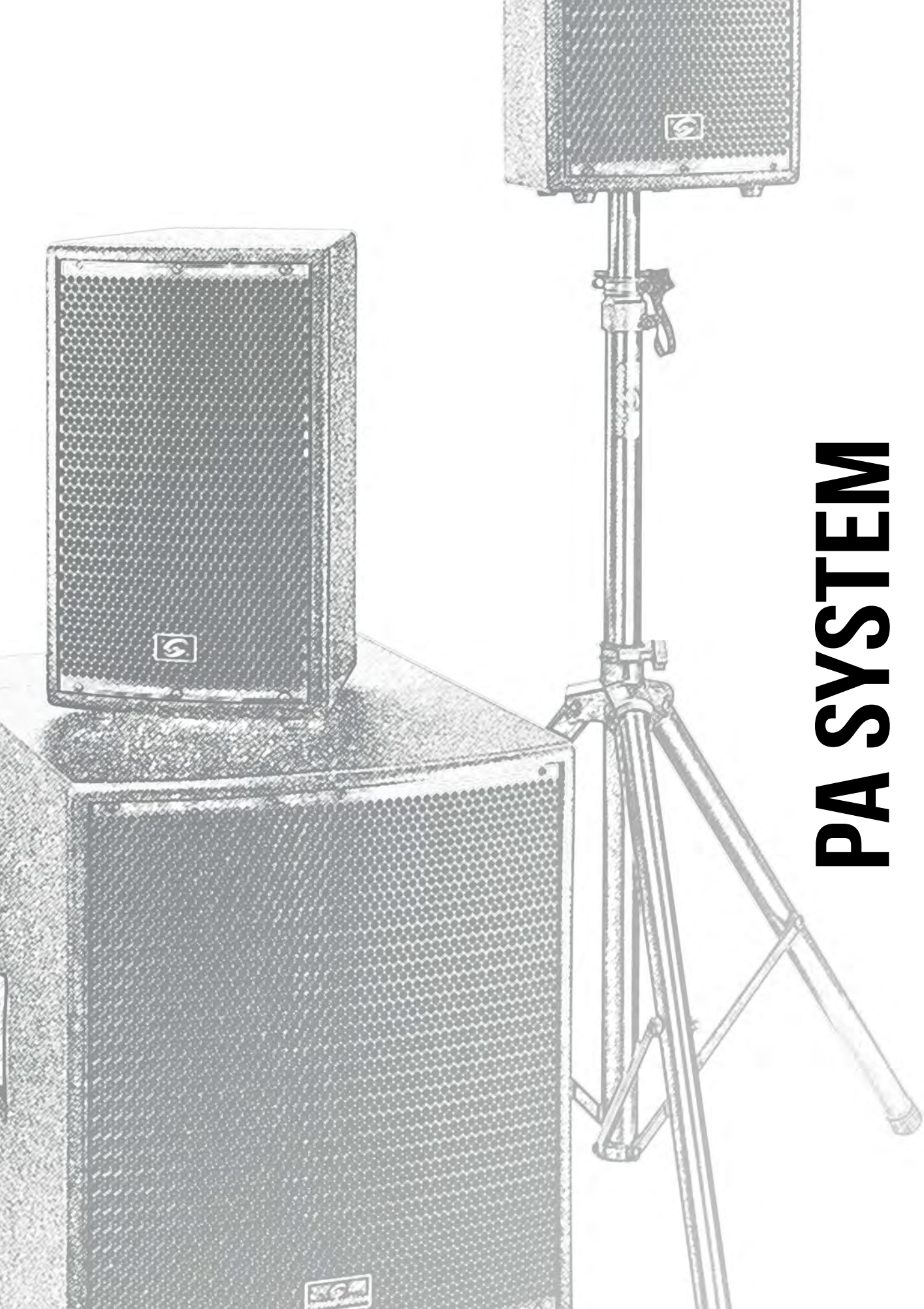

PA SYSTEM

Hyper series

HYPER PLAY 6AMW - 6.5" Portable PA System with UHF Wireless MIC, MP3/Bluetooth, and Rechargeable Battery

HYPER PLAY 6AMW is a new battery-powered portable loudspeaker with 6.5" woofer. It features a 4-channel mixer, MP3 player, USB, SD-card, and Bluetooth™ connection and professional a UHF wireless microphones with handheld transmitter. HYPER PLAY 6AMW is AC or battery operated with about 5 hours battery life. The Built-in Class-D amplifiers delivers 150W Program Power. The stylish polypropylene enclosure is strong and lightweight, with metallic grille, and 36mm standard pole mount hole. Included in the package there is a padded cover with side pockets to hold microphone and mains adapter.

- Portable 2-Way Active Speaker with Rechargeable Battery
- Sturdy polypropylene enclosure compact and lightweight
- 300W Peak Power Class-D power amplifier (Peak Power, AC powered)
- 6,5" woofer with 1" compression driver
- MP3 player with USB, SD Card and Bluetooth™
- UHF Handheld Wireless Microphone
- 2 Microphone/Line inputs
- 1 Stereo Input (Mini Jack /RCA)
- 2-Band EQ
- Lead Rechargeable Battery with 5-hour battery life
- 36 mm standard pole mount
- Handle on top
- Padded Cover with side-pockets

- Frequency response: 80Hz-20KHz
- Max. SPL: 110 dB (values referred to mains power)
- LF: 6,5" / HF: 1" Compression Driver
- Directivity (HxV): 90° x 60°, Symmetric
- Crossover Frequency: 5.1 kHz
- Amp Power (Program/Peak): 150W / 300W, Class-D (values referred to mains power)
- Controls: 2xMic/Line level, UHF Mic Level, AUX/Bluetooth/MP3 level, AUX-MP3 Switch, Master level
- 2-Band EQ (BASS/TREBLE): Bass 100Hz (+/- 12dB); Treble 10kHz (+/- 12dB)
- Connections: 2xMic/Line Combo, AUX Stereo Mini Jack, Line In L&R RCA Jack
- Indicators: Power, Clip, Wireless Mic On, RF Mic, Battery Charge
- Media player: USB, SD-Card, Bluetooth™, LCD Display
- Media player controls: Stop, Play/Pause, Next track, Previous track, Mode
- Power Mains: 19V - 3,42A
- Rechargeable Battery: 12V-2600 mAh Lead Battery (TP12-2.6 type)
- Battery Size (WxHxD): 70mm x 47mm x 100mm
- Battery Charge/Discharge Cycle: 2hours / 5hours
- Wireless Microphone Frequency: Carrier Freq. UHF 863-865MHz; Operating Freq. 863.1MHz.
- Frequency Response: 50Hz – 17kHz
- Transmitter Power: 10mW
- Modulation Type: FM
- Battery Voltage: 3V (2x1.5V AA-Type Batteries) - Continuous use about 7 hours
- Hand-held Mic. Size (W/DxH): Ø35 (min) - Ø52 (max) x 245 mm
- Wireless Mic. Weight: 0.245 kg (batteries included)
- Housing / Grille material: Polypropylene / 0.8mm Steel
- 1 Handle on top + Padded Cover with side pockets
- Pole Mount: Standard D36 mm
- Speaker Dimension (WxHxD): 220 x 320 x 200 mm - Net Weight: 4.4 kg (Battery included)

CODE	MSRP EUR	MSRP GBP
E547E	€230,14	£211.27



Go-Sound series

GO-SOUND family is now enhanced by a new battery-powered portable PA series with 12" and 15" woofers GO-SOUND 12AMW and 15AMW that, in addition to MP3 player, USB, SD-card, and Bluetooth™ connection of MULTIMEDIA version, integrates two VHF wireless microphones with handheld transmitters, an Echo effect for the two microphone inputs and the two wireless microphones, a useful 5-band graphic EQ and a handy trolley with wheels and telescopic handle on top. They are AC or battery operated; the latter with a duration of about 2.5 hours at maximum volume and full charge. Amplification, as well as for the previous GO-SOUND 12A and AM versions, is equipped with a Class-AB 800W (mains powered) peak-power module. The polypropylene enclosure is strong and lightweight, with metallic grille, 36mm standard pole mount hole, and acoustic foam to protect the woofer and give a pleasant look.

GO-SOUND 8AMW - Portable 2-Way Active Speaker with Rechargeable Battery

- Portable 2-Way Active Speaker with Rechargeable Battery
- Sturdy polypropylene enclosure yet compact and lightweight
- 250W* Class-D power amplifier
- 8" woofer with 1" compression driver
- MP3 player with USB, SD Card and Bluetooth™
- VHF Handheld Wireless Microphone
- Microphone/Line inputs
- 2-Band Graphic EQ
- Lithium Rechargeable Battery with 4-hour battery life
- 36 mm standard pole mount
- Handle on top
- *Peak power, mains powered

- Speaker Type: Portable 2-way active speaker with rechargeable battery
- Frequency response: 70Hz-19KHz
- Max. SPL: 107dB (Mains Powered)
- Transducers: 8" Woofer; 1" Compression Driver
- Directivity (HxV): 90° x 40° - 60°
- Horn Type: Asymmetric
- Amplifier: 125W* Program, 250W* Peak Class-D (*Mains Powered)
- Controls: Mic/Line level, VHF Mic Level, AUX/Bluetooth/MP3 level, AUX-MP3 Switch, Master level
- 2-Band Graphic EQ: 20-100 Hz, 9K-20KHz (+/- 15dB)
- Connections: Mic/Line Combo, AUX Stereo Mini Jack, Line Out L&R RCA Jack
- Indicators: Power, Clip, Wireless Mic On, RF Mic, Battery Charge
- Media player: USB, SD-Card, Bluetooth™, LCD Display
- Media player controls: Stop, Play/Pause, Next track, Previous track, Mode
- Mains Power: 15VDC - 1.5A
- External Power (no charge function): 12Vcc
- Rechargeable Battery: 11.1V-2200mAh Lithium Battery (HKD-22 type)
- Battery Life: 4 hours
- Battery Dimension (WxHxD): 56 x 19 x 71mm
- Housing material: Polypropylene
- Grille: 0.8mm, steel
- Handles: 1 on top
- Pole Mount: Standard D36 mm
- Speaker Dimension (WxHxD): 248 x 395 x 198 mm
- Net Weight: 4.6 kg

CODE	MSRP EUR	MSRP GBP
E384E	€154,46	£141.79



Go-SOUND series

GO-SOUND 10AMW - Portable 2-Way Active Speaker with Trolley and Rechargeable Battery

- Portable 2-Way Active Speaker with Trolley and Rechargeable Battery
- Sturdy polypropylene enclosure yet compact and lightweight
- 360W* Class-D power amplifier
- 10" woofer with 1" compression driver
- MP3 player with USB, SD Card and Bluetooth™
- VHF Handheld Wireless Microphone
- Microphone/Line inputs
- 2-Band Graphic EQ
- Rechargeable Battery with 4-hour battery life
- 36 mm standard pole mount
- Trolley system with wheels and one telescopic handle on top + 2 side handles
- *Peak power, mains powered

- Speaker Type: Portable 2-way active speaker with trolley and rechargeable battery
- Frequency response: 65Hz-19KHz
- Max. SPL: 109dB (Mains Powered)
- Transducers: 10" Woofer, 1" Compression Driver
- Directivity (HxV): 90° x 40° - 60°
- Horn Type: Asymmetric
- Amplifier: 180W* Program, 360W* Peak Class-D (*Mains Powered)
- Controls: Mic/Line level, VHF Mic Level, AUX/Bluetooth/MP3 level, AUX-MP3 Switch, Master level
- 2-Band Graphic EQ: 20-100 Hz, 9K-20KHz (+/- 15dB)
- Connections: Mic/Line Combo, AUX Stereo Mini Jack, Line Out L&R RCA Jack
- Indicators: Power, Clip, Wireless Mic On, RF Mic, Battery Charge
- Media player: USB, SD-Card, Bluetooth™, LCD Display
- Media player controls: Stop, Play/Pause, Next track, Previous track, Mode
- Mains Power: 15VDC - 1.5A
- External Power (no charge function): 12Vcc
- Rechargeable Battery: 12V-4500mAh Lead Battery (6FM4.5 type)
- Battery Life: 4 hours
- Battery Dimension (WxHxD): 90.5 x 70 x 102mm
- Housing material: Polypropylene
- Grille: 0.8mm, steel
- Handles: 1 telescopic on top, 2 on sides
- Trolley: 2 Wheels and 1 Telescopic Handle, 31 cm max. extension
- Pole Mount: Standard D36 mm
- Speaker Dimension (WxHxD): 308 x 493 x 250 mm
- Net Weight: 6.4 kg



CODE	MSRP EUR	MSRP GBP
E385E	€186,31	£171.03



Go-SOUND series

GO-SOUND 15AMW- Battery-Powered Portable 2-Way Active Speaker with Trolley and MP3/Bluetooth™ player

- Sturdy polypropylene enclosure yet compact and lightweight
- 800W Class-AB power amplifier (Peak power, mains powered)
- 15" woofer, 1" compression driver
- MP3 player with USB, SD Card and Bluetooth™
- Dual VHF Handheld Wireless Microphone
- Echo Effect
- Unbalanced Microphone/Line inputs
- 5-Band Graphic EQ
- Rechargeable Battery with 2.5-hour battery life
- 36 mm standard pole mount
- Trolley system with wheels and one telescopic handle on top + 2 side handles

- Speaker Type: Portable 2-way active speaker with rechargeable battery
- Frequency response: 60Hz-19KHz
- Max. SPL: 114dB (Mains Powered)
- Transducers: 15" Woofer, 1" Compression Driver
- Directivity (HxV): 90° x 40° - 60°
- Horn Type: Asymmetric
- Amplifier: 400W* Program, 800W* Peak Class AB (*Mains Powered)
- Controls: Mic1&2 level, Line level, Echo level, Bluetooth/MP3 level, Master level, Wireless Mics On, W. Mic1 level, W. Mic2 level
- 5-Band Graphic EQ: 100Hz, 330Hz, 1KHz, 3,3KHz, 10KHz (+/- 12dB)
- Connections: Mic 1&2 6.3mm TS Jack, Line In L&R RCA Jack, Line Out L&R RCA Jack
- Indicators: Power, Clip, Wireless Mic On, RF Mic1, RF Mic2, Battery Charge
- Media player: USB, SD-Card, Bluetooth™, 2x16 LCD Display
- Media player controls: Stop, Play/Pause, Next track, Previous track, Mode
- Mains Power: 230VAC-50Hz
- Fuse: T1A-250V
- External Power (no charge function): 12Vcc
- External Add. Fuse: T10A-250V
- Rechargeable Battery: 12V-7AH Lead Battery (TC12-7.0 type)
- Battery Dimension (WxHxD): 151 x 100 (poles Included) x 65 mm
- Housing material: Polypropylene
- Grille: 0.8mm, steel
- Handles: 2 on sides; 1 telescopic on top
- Trolley: 2 Wheels and 1 Telescopic Handle, 31 cm max. extension
- Pole Mount: Standard D36 mm
- Speaker Dimension (WxHxD): 440 x 703 x 370 mm
- Net Weight: 14.0 kg

CODE	MSRP EUR	MSRP GBP
L756L	€351,22	£322.42



Go-Sound series

GO-SOUND 12AMW - Battery-Powered Portable 2-Way Active Speaker with Trolley and MP3/Bluetooth™ player

- Sturdy polypropylene enclosure yet compact and lightweight
- 800W Class-AB power amplifier (Peak power, mains powered)
- 12" woofer, 1" compression driver
- MP3 player with USB, SD Card and Bluetooth™
- Dual VHF Handheld Wireless Microphone
- Echo Effect
- Unbalanced Microphone/Line inputs
- 5-Band Graphic EQ
- Rechargeable Battery with 2.5-hour battery life
- 36 mm standard pole mount
- Trolley system with wheels and one telescopic handle on top + 2 side handles

- Speaker Type: Portable 2-way active speaker with rechargeable battery
- Frequency response: 68Hz-19KHz
- Max. SPL: 112dB (Mains Powered)
- Transducers: 12" Woofer, 1" Compression Driver
- Directivity (HxV): 90° x 40° - 60°
- Horn Type: Asymmetric
- Amplifier: 400W* Program, 800W* Peak Class AB (*Mains Powered)
- Controls: Mic1&2 level, Line level, Echo level, Bluetooth/MP3 level, Master level, Wireless Mics On, W. Mic1 level, W. Mic2 level
- 5-Band Graphic EQ: 100Hz, 330Hz, 1KHz, 3.3KHz, 10KHz (+/- 12dB)
- Connections: Mic 1&2 6.3mm TS Jack, Line In L&R RCA Jack, Line Out L&R RCA Jack
- Indicators: Power, Clip, Wireless Mic On, RF Mic1, RF Mic2, Battery Charge
- Media player: USB, SD-Card, Bluetooth™, 2x16 LCD Display
- Media player controls: Stop, Play/Pause, Next track, Previous track, Mode
- Mains Power: 230VAC-50Hz
- Fuse: T1A-250V
- External Power (no charge function): 12Vcc
- External Add. Fuse: T10A-250V
- Rechargeable Battery: 12V-7AH Lead Battery (TC12-7.0 type)
- Battery Dimension (WxHxD): 151 x 100 (poles Included) x 65 mm
- Housing material: Polypropylene
- Grille: 0.8mm, steel
- Handles: 2 on sides; 1 telescopic on top
- Trolley: 2 Wheels and 1 Telescopic Handle, 31 cm max. extension
- Pole Mount: Standard D36 mm
- Speaker Dimension (WxHxD): 375 x 588 x 320 mm
- Net Weight: 13.4 kg

CODE	MSRP EUR	MSRP GBP
L755L	€310,37	£284.92



GO-SOUND POCKET MIC - Kit Bodypack, Headset, and Lavalier Mic for GO-SOUND AMW Speakers

The Go-Sound Pocket Mic is an optional set including a VHF bodypack transmitter, a lavalier microphone, and a headset microphone. It is intended for all of those owners of SOUNDSATION GO-SOUND AMW Active Speakers who need total freedom of movement during their sessions.

- Compatible with GO-SOUND 8AMW / 10AMW / 12AMW / 15AMW
- VHF Transmission with SMD Technology
- 175MHz VHF Frequency (NOTE: Before purchasing this product, make sure that the wireless microphone frequency of your Go-Sound 8-10 AMW – or at least one of the two frequencies for Go-Sound AMW 12-15 AMW – is 175MHz)
- Plug and play setup
- 30m ideal distance (without obstacles)
- Simple and lightweight bodypack
- Lightweight Headset with cardioid electret capsule
- Tie Microphone with clip and omni-directional electret capsule

- Carrier Frequency: VHF - 175.00MHz
- Transmitter Power: 10mW
- Modulation Type: FM
- Deviation: 37KHz
- Spurious Emission: > 30dB
- Continuous Using: 7 hours
- Frequency Stabilization: Automatic calibration
- Dynamic Range: > 90dB
- Total Harmonic Distortion: < 0.5%
- Frequency Response: 40Hz~15KHz ±3dB
- Input Connector: 1/8" mono Jack (without thread)
- Knobs: Mic Volume
- LED: Red (battery-low)
- Battery Voltage: 3V (2x1.5V AA Battery)
- Headset Microphone: Cardioid electret capsule
- Headset Connector: 1/8" Mini-Jack (90° without thread)
- Lavalier Microphone: Omni-directional electret capsule
- Lavalier Connector: 1/8" Mini-Jack (without thread)



CODE	MSRP EUR	MSRP GBP
J197J	€27,37	£25.13

POCKETLIVE U16HBT Portable Amplifier with UHF 16-channel wireless system, MP3 and Bluetooth™

Dedicated to all those who need maximum portability and are always "on the road", the POCKETLIVE U16HBT is a 35W battery-powered PA system with 16-channel UHF wireless microphone system, MP3 player with Bluetooth™, line and microphone inputs, and more. Its weight of about 3kg (batteries included), the strap and the carrying bag make it suitable for almost any situation where you need to play loud but there isn't even any electrical outlet: in classroom, sport contexts, ceremonies, tourism and more. The internal battery lasts more than five hours (continuous use at maximum volume). The UHF 16-channel wireless microphone operates in ISM band (863-865MHz), can be used even in high interference environments and does not require any special authorization within the European Community. The MP3 player with Bluetooth™, the SD-Card and USB lets you play your playlists and can also be operated via a handy remote control. The bag, which features a shoulder strap and a large side pocket, has an opening with zipper and net on speaker side, and allows the use of POCKETLIVE U16 also inside the bag. Finally, under the amplifier is a hole that, by mounting the supplied adapter, allows the use on a standard microphone stand.

- SMT integrated technology with surface mount components designed for maximum energy-efficiency and environmental friendliness
- Designed for use in schools, sport events, coaching, religious contexts, etc.
- 35 Watt High-quality power amplifier with 6" full-range speaker
- Lithium battery pack with over 5 hours operation (maximum volume with full-charged batteries)
- Professional 16-channel UHF wireless with IR setup system
- ISM-Europe Band operation (863-865MHz); it doesn't need any special license in Europe
- Handheld microphone with cardioid dynamic capsule
- MP3 player with Bluetooth™, USB, SD-Card e IR remote controller
- Built-in Echo effect on wired/wireless microphones
- Bag with shoulder strap, side pocket and opening with zipper and net on speaker side, which allows the use of POCKETLIVE U16 also inside the bag
- 5V DC USB charger out (max 500mA) for smartphones and other external devices
- Microphone stand adapter
- Power Amplifier: 35W
- Input / Output Connections: 1x Wired Mic, 2x Line In (one on the MP3 player), 1x Line Out
- Speaker size: 6" full-range
- Dynamic range: >95dB
- Total Harmonic Distortion: < 0.8%
- frequency Response: 40Hz-15KHz ±3dB
- Battery: Rechargeable Lithium Battery Pack 14.8V - 4000mA
- External Power Supply: Input 100-240Vac, 50/60Hz – Output 19Vcc, 3.42A (70W Max)
- Dimensions (WxHxD): 296 x 180 x 175 mm
- Net Weight: 2.6kg (batteries included)
- Receiving Band: UHF 863-865MHz
- Receiver Total Harmonic Distortion: < 0.4%
- Receiver Frequency Response: 40Hz-15KHz ±3dB
- Receiver Signal/Noise Ratio: > 95dB
- Receiving Sensibility: >7dBuV (SINAD=30dB)
- De-Emphasis: 75uS
- Transmission Power: 10mW
- Transmitter Maximum Deviation: ±20KHz
- Handhel Mic. Batteries: 2x 1.5V AA-Type
- Handhel Mic. Battery Life: 5 hours
- Handhel Mic. Dimensions (W/DxH): Ø50 x 232 mm
- Handhel Mic. Net Weight: 0.26kg (batteries included)
- MP3 Player Audio Formats: MP3, WMA, WMW
- IR remote controller
- USB and SD-Card slots

CODE	MSRP EUR	MSRP GBP
L216L	€236,48	£217.09

POCKETLIVE U16P-KIT - Professional Headset Microphone + Pocket Trasmmitter Kit for POCKETLIVE U16

The kit consists of a 16-channel UHF Pocket Transmitter and a professional headset microphone for SOUNDSATION POCKETLIVE U16H-BT.

CODE	MSRP EUR	MSRP GBP
A702A	€54,03	£49.60



BLACKPORT-80BTRW -Battery Powered PA System with trolley, VHF wireless microphone, Bluetooth™, MP3 player and reverb

Dedicated to all those who need maximum portability and are constantly “on the road”, the BLACKPORT-80BTRW is a battery-powered 80W max. PA system, featuring built-in 4-channel mixer, VHF wireless microphone, reverb, Bluetooth™ and MP3 player with SD-Card and USB slots. Battery life is 6 hours at full volume and with fully charged batteries. Its lightweight and rugged construction combined with the extremely useful trolley, make it an ideal tool in all “on the fly” situations such as parties, one-man band gigs, and small PA needs, without risks of damage but with good performance in terms of power and audio quality.

- Portable battery-powered PA system 80W
- Built-in 4-channel mixer
- VHF wireless microphone
- Mic input with Combo connector (XLR + 1/4" Jack)
- Instrument/Mic input with 1/4" jack connector
- RCA a mini-jack stereo line inputs
- 2-Band EQ
- MP3 player with Bluetooth™, USB and SD-Card slots
- Rechargeable batteries with LED charge level display and 6-hour battery life
- Rugged enclosure in MDF with aluminum corners
- Trolley system with telescopic handle and wheels
- Remote control for MP3 player
- D36mm pole-mount



- 2-way active speaker with bass-reflex port
- Frequency Response: 70Hz – 20kHz +/- 3dB
- LF: 8" woofer
- HF: 1" dome tweeter
- Peak Power: 80W
- PRG Power: 40W
- VHF wireless operating Frequency: 175 MHz
- Transmission Output Power: 10mW max.
- Operating distance: 30m without direct obstacles
- Input Voltage: 220-240V/50Hz
- Fuse: T1.6A/250V
- Battery: 6FM7-Type Rechargeable Lead Battery 12V-7AH/20HR
- Battery life: Over 6 hours (at full volume of the system when fully charged)
- Battery size (WxHxD): 150 x 100 (including poles) x 65mm
- Product size: 390 x 300 x 485mm
- Net Weight: 17.5 kg

CODE	MSRP EUR	MSRP GBP
L738L	€272,82	£250.45



BLUEPORT FX - 2x100W Portable PA System with active mixer and two passive 2-Way Speakers

BLUEPORT FX is the result of years of experience gathered by SOUNDSTATION in Portable Sound systems, a segment where quality, versatility and value for money are absolutely essential. This active amplified portable PA system includes two passive speakers with 10 “woofers and integrated amplified mixer. In addition to the MP3 player with USB, SD card and Bluetooth™, the system integrates a 24Bit DSP FX with 16 genuine effects to add to the MIC inputs choosing the level for each channel. The integrated mixer is equipped with a Class-D 2x100W (RMS) amplifier. The enclosures (ABS) are strong and lightweight and have a pleasant look.

- Two passive speakers with integrated amplified mixer
- Class-D 2x100W (RMS) Amplifier
- Speakers with 10" Woofers and 1" compression driver
- Dual Band Equalizer (Low/High frequencies)
- MP3 player with USB, SD card and Bluetooth™
- 4 Microphones/Line Inputs
- 1 Stereo RCA/JACK 1/4" Line Input
- 1 Stereo RCA Line Output
- 24Bit DSP FX with 16 genuine effects
- Infrared receiver for remote control
- 35 mm hole for pole mounting
- Sturdy, compact and lightweight cabinets (ABS)



- Frequency Response - 65 Hz - 20KHz [- 10dB] ; 65Hz-19KHz [- 3dB]
- System Max SPL / Sensitivity - 118dB / 95dB
- HF Type - Compression Driver ; Throat diameter / Voice coil diameter - 1" / 1" ; Driver throat diameter - 80mm ; Directivity (HxV) / Horn Type - 90°x40°-60° / Asymmetric ; Magnet Material / Weight - Ferrite Magnet Structure / 225g ; RMS Power - 25W ; Sensitivity(1W/1m) - 106dB ; Crossover Frequency / Filter Slope - 3KHz / 6dB/Octave ; Impedance - 8 Ohm
- LF Woofer Diameter - 10" ; Voice coil diameter - 10" ; Voice coil diameter - 1.5" ; Magnet Material / Weight - Ferrite Magnet Structure / 677.3g ; RMS Power - 100W ; Frequency Response - 63Hz - 3.5KHz ; Max SPL (1W/1m) - 94dB ; Impedance - 4 Ohm
- Amplifier Class - D ; Power RMS / Peak - 2 x 100W / 2 x 250W ; Output Connectors - 2x 1/4" Jack
- Input Channels - 4 Mic/Line + 1 Stereo Line
- Phantom Power - (CH1-4) +48V
- EQ High (CH 1-4 and Master) - Cut-off freq: 1KHz / Gain: +/-15dB
- EQ Low (CH 1-4 and Master) - Cut-off freq: 500Hz / Gain: +/-15dB
- Digital Effects - 16 Presets with Level Control (CH1-4)
- Digital Multimedia Player - USB, SD-CARD and Bluetooth
- Power Requirement - 230Vac-50Hz ; Power Consumption - 350W ; Power Switch - YES ; Connector - VDE ; Fuse - T3.15A - 250V
- Speaker Housing material - ABS
- Grille material / thickness - Steel / 0.8 mm
- Mixer Housing material - ABS
- Handles - YES
- Pole Mount - YES/35mm
- Single Speaker Size (WxHxD) - 330 x 300 x 490mm

CODE	MSRP EUR	MSRP GBP
E577E	€500,05	£459.05



LIVEMAKER SERIES

LIVEMAKER 1521 MIX - 1500W 2.1 Portable PA System with 8-Ch Mixer, Effect, and Bluetooth

The LIVEMAKER 1521 MIX, 1500W 2.1 PA system, is designed as a compact system for live and educational purposes. It integrates an 8-channel mixer with Digital Effects and Bluetooth, three Class-D amplifiers with switching power supply for 1500W total peak power, a generous 15" subwoofer and two satellites with a 8" woofer and 1.4" HF driver. It represents the perfect answer to those who need a professional sound system, but have problems of space, move with not very big cars or vans, and have a lot of audio sources to be connected. Not only, but they also need a professional reverb and, if necessary, want to connect a mobile phone, a tablet or a computer to play their play-lists. Both the subwoofer and the two tops are equipped with 36mm hole for pole or tripod. The reinforced MDF cabinets are robust, lightweight and finished with anti-scratch paint, to make them resistant to the rigors of the stage.

- 2.1 Compact PA System with 2 passive satellites and 1 active subwoofer
- 2 passive Tops with reinforced MDF cabinet, featuring 8" and 1.44" Titanium dome driver
- Active bass-reflex subwoofer with reinforced MDF enclosure, featuring a 15" woofer for up to 128dB sound pressure
- 8 Channel mixer with 4 MIC Inputs, 1 Stereo Line Input, 1 Stereo Bluetooth Input
- 2-Band EQ, 16 Digital Effects (Mic channels only)
- 1500W Peak power class-D amplifier with high-efficiency, low-heat dissipation switching power supply
- Balanced MIC/Line Inputs and Balanced Outputs
- Standard D36mm pole mount adapter over the subwoofer top and under the two satellites
- 2 handles on subwoofer (1 on each side)
- 1 Rear handle on each top

- System Max SPL: 129 dB
- System Frequency Response: 40 Hz-20 kHz
- Satellite Power RMS / Peak: 300W / 600W (each)
- Satellite Frequency Response: 80 Hz-20 kHz
- Satellite Sensitivity (1W@1m): 97 dB
- Satellite Max. SPL (@1m): 122 dB
- Satellite nominal Impedance: 8 ohms
- Satellites Input Connectors: 2 x Speakon
- Satellite LF: 1 x 8" with 2" voice coil
- Satellite HF: 1 x 1.4" voice coil, titanium dome
- Satellite Crossover Frequency: 3 kHz, 12 dB/octave
- Speaker Pole Adapter: Ø36mm
- Satellite Size (WxHxD): 614x510x334 mm (2pcs carton); 270x450x245 mm (one speaker)
- Satellite Weight: Net weight 9.2kg; Gross weight 20kgs (2pcs carton)
- Inputs: MIC XLR, 6.3mm jack, RCA
- EQ Control: Low: +/-15dB; High: +/-15dB
- Bluetooth connection distance: >6m
- Subwoofer amplifier: 1 x 500W RMS @ 4ohms
- Satellites amplifier: 2x 250W RMS @ 8ohms
- Sub LF driver: 15" with 3" voice coil.
- Sub Frequency response: 40 Hz-150 Hz
- Sub Sensitivity (1m/1W): 98 dB
- Sub Max. SPL (@1m): 128 dB
- Mains: AC 230V 50Hz (Fuse: T8A/250V)
- Subwoofer Size (WxHxD): 810x725x580 mm (Packing); 465x620x650 mm (sub)
- Subwoofer Net Weight: net weight 31.4kg; packing 35kg
- Housing material: MDF + Anti-scratch Printing (Black finish)
- Handles: 2 on subwoofer (1 on each side); 1 on rear side of each top
- Pole Mount Adapter: Standard ;20



CODE	MSRP EUR	MSRP GBP
L935L	€878,41	£806.38

LIVEMAKER SERIES

LIVEMAKER 1021 MIX - 900W 2.1 Portable PA System with 8-Ch Mixer, Effect and Bluetooth

The LIVEMAKER 1021 MIX, 900W 2.1 PA system, is designed as a compact system for live and educational purposes. It integrates an 8-channel mixer with Digital Effects and Bluetooth, three Class-D amplifiers with switching power supply, for 900W total peak power, a generous 10" subwoofer and two satellites with a 6.5" woofer and 1" compression driver. It represents the perfect answer to those who need a professional sound system, but have problems of space, move with not very big cars or vans, and have a lot of audio sources to be connected. Not only, but they also need a professional reverb and, if necessary, want to connect a mobile phone, a tablet or a computer to play their play-lists. Both the subwoofer and the two tops are equipped with 36mm hole for pole or tripod. The reinforced MDF cabinets are robust, lightweight and finished with anti-scratch paint, to make them resistant to the rigors of the stage.

- 2.1 Compact PA System with 2 passive satellites and 1 active subwoofer
- 2 passive Tops with reinforced MDF cabinet, featuring 6.5" and 1" silk cloth dome driver
- Active bass-reflex subwoofer with reinforced MDF enclosure, featuring a 10" woofer for up to 123dB sound pressure
- 8 Channel mixer with 4 MIC Inputs, 1 Stereo Line Input, 1 Stereo Bluetooth Input
- 2-Band EQ, 16 Digital Effects (Mic channels only)
- 900W Peak power class-D amplifier with high-efficiency, low-heat dissipation switching power supply
- Balanced MIC/Line Inputs and Balanced Outputs
- Standard M20mm pole mount adapter over the sub top and D36mm under the two satellites
- 2 handles on subwoofer (1 on each side)
- 1 Rear handle on each top



- System Max SPL: 124 dB
- System Frequency Response: 45 Hz-20 kHz
- Satellite Power RMS / Peak: 150W / 300W (each)
- Satellite Frequency Response: 90 Hz-20 kHz
- Satellite Sensitivity (1W@1m): 90 dB
- Satellite Max. SPL (@1m): 111 dB
- Satellite nominal Impedance: 8 ohms
- Satellites Input Connectors: 2 x Speakon
- Satellite LF: 1 x 6.5" with 1.5" voice coil
- Satellite HF: 1 x 1" voice silk cloth dome
- Satellite Crossover Frequency: 3 kHz, 12 dB/octave
- Speaker Pole Adapter: Ø36mm
- Satellite Size (WxHxD): 225 x 346 x 215 mm
- Satellite Weight: 6.4 kg
- Inputs: MIC XLR, 6.3mm jack, RCA
- EQ Control: Low: +/-15dB; High: +/-15dB
- Bluetooth connection distance: >6m
- Subwoofer amplifier: 1 x 300W RMS @ 4ohms
- Satellites amplifier: 2x 150W RMS @ 8ohms
- LF driver: 10" with 2.5" voice coil
- Sub Frequency response: 45 Hz-150 Hz
- Sub Sensitivity (1m/1W): 90 dB
- Sub Max. SPL (@1m): 123 dB
- Mains: AC 230V 50Hz (Fuse: T3.15A/250V)
- Subwoofer Size (WxHxD): 340 x 429 x 460 mm
- Subwoofer Net Weight: 22 kg
- Housing material: MDF + Anti-scratch Printing (Black finish)
- Handles: 2 on subwoofer (1 on each side); 1 on rear side of each top
- Pole Mount Adapter: Standard M20

CODE	MSRP EUR	MSRP GBP
L911L	€601,44	£552.12

LIVEMAKER SERIES

LIVEMAKER X SET - 1800W Peak Power 2.1 Portable Column PA System with DSP

LIVEMAKER X is the result of years of experience gathered by SOUNDSATION in Portable Sound systems, a segment where quality, versatility and value for money are absolutely essential. LIVEMAKER X system with its powerful 1800-watt (Peak) power amp delivers astounding performance for mobile applications especially for musicians and DJs. The system is equipped with a high-performance 10" subwoofer, two satellite speakers (6 x 2.75" Wide-band Speakers) and integrated mixer. In addition to the Bluetooth, the system integrates a DSP for Audio with 4 Presets and a 24Bit DSP FX with 16 genuine effects to add to the MIC inputs choosing the level for each channel. The enclosures (ABS for the satellites and Plywood for the sub-woofer) are strong and lightweight and have a pleasant look.

- 1 x Subwoofer with integrated mixer and 2 x Satellite Passive speakers
- Class-D 2 x 600W (RMS) Amplifier
- One 10" Woofer (Subwoofer) and 6 x 2.75" Wide-band Speakers (3 for each satellite speaker)
- 2 Microphones/Line Inputs with 3 Band Equalizer (Low/Middle/High frequencies)
- Bluetooth
- AUX Input with 1 Stereo RCA Line Input, 2 x JACK 1/4 Inputs and 1 x Mini Jack Stereo Input
- Dual Band Equalizer on AUX Input
- A DSP for Audio output with 4 presets and a 24Bit DSP FX with 16 genuine effects
- 25 mm hole for satellite speaker pole mounting
- Sturdy, compact and lightweight cabinets (ABS for the satellites and Plywood for the subwoofer).
 Speaker Stands and Bag included



- System: Portable Column PA Speakers; Speaker Type: 2.1 Portable System
- Satellite and Subwoofer Max. SPL(@1m): 121dB
- Frequency Range: 50Hz-20kHz; Satellite Frequency response: 250Hz-20kHz; Subwoofer Frequency response: 50Hz-250Hz
- Satellite RMS / Peak Power Capacity : 150W/450 W (each satellite speaker)
- Sensitivity (1m/1W) Satellite/Subwoofer: 98dB/95dB
- Satellite Nominal impedance: 8ohm
- Satellite Input: 1 x Speakon connector
- Satellite HF driver: 6 x 2.75" Wideband Speakers voice coil
- Satellite Crossover frequency: 250Hz, -12 dB/octave
- Satellite HF protection: Short protection
- Satellite Pole mount: Ø 25mm
- Satellite Housing material: ABS
- Satellite Dimensions (WxDxH): (2x) 107x107x560mm; Satellite Net weight: (2x) 1.72kg
- Subwoofer Inputs: 2x XLR/6.3mm Jack Combo, Mini Jack Stereo input 3.5mm, RCA, 6.3 Jack L+R/Bluetooth
- MIC, Line, RCA Input impedance: 4.7 kΩ (MIC), 22 kΩ (LINE & RCA)
- MIC/Line in Sensitivity: -50dB (MIC), -20dB (LINE)
- Line in Sensitivity: -20dB
- EQ Control: LOW Freq, +/-12dB; MID Freq, +/-11dB; HIGH Freq, +/-11dB
- DSP: 24Bit DSP for Audio Output with 4 presets and a 24Bit DSP FX with 16 genuine effects dedicated to CH1 and CH2
- Subwoofer amplifier: 300W RMS @ 4ohm; Satellites amplifier: 150W RMS @ 8ohm (for each satellite speaker)
- Bluetooth connection distance: 30m
- LF driver: 1 x 10" Woofer 2.0" voice coil
- Mains: 110V~120V / 230V~240V
- Fuse: 110V~120V T10A / 230V~240V T5A
- Pole Mount (subwoofer): M20 thread
- Subwoofer Dimensions (WxDxH): 325x520x383mm; Subwoofer Net weight: 15.9kg
- Subwoofer Housing material: Plywood
- Stand Material: Steel; Stand Diameter: 25mm; Stand Height: 1.8m; Stand Carrying Bag: Included
- Accessories: 2x 3m Speakon-Speakon speaker cables, 1x 1.5m Schuko-IEC power cable, 1x Padded bag for speaker columns, 1: speaker stand set with bag, Owner's Manual (ENG/ITA)



CODE	MSRP EUR	MSRP GBP
E861E	€776,61	£712,93

MIXERS

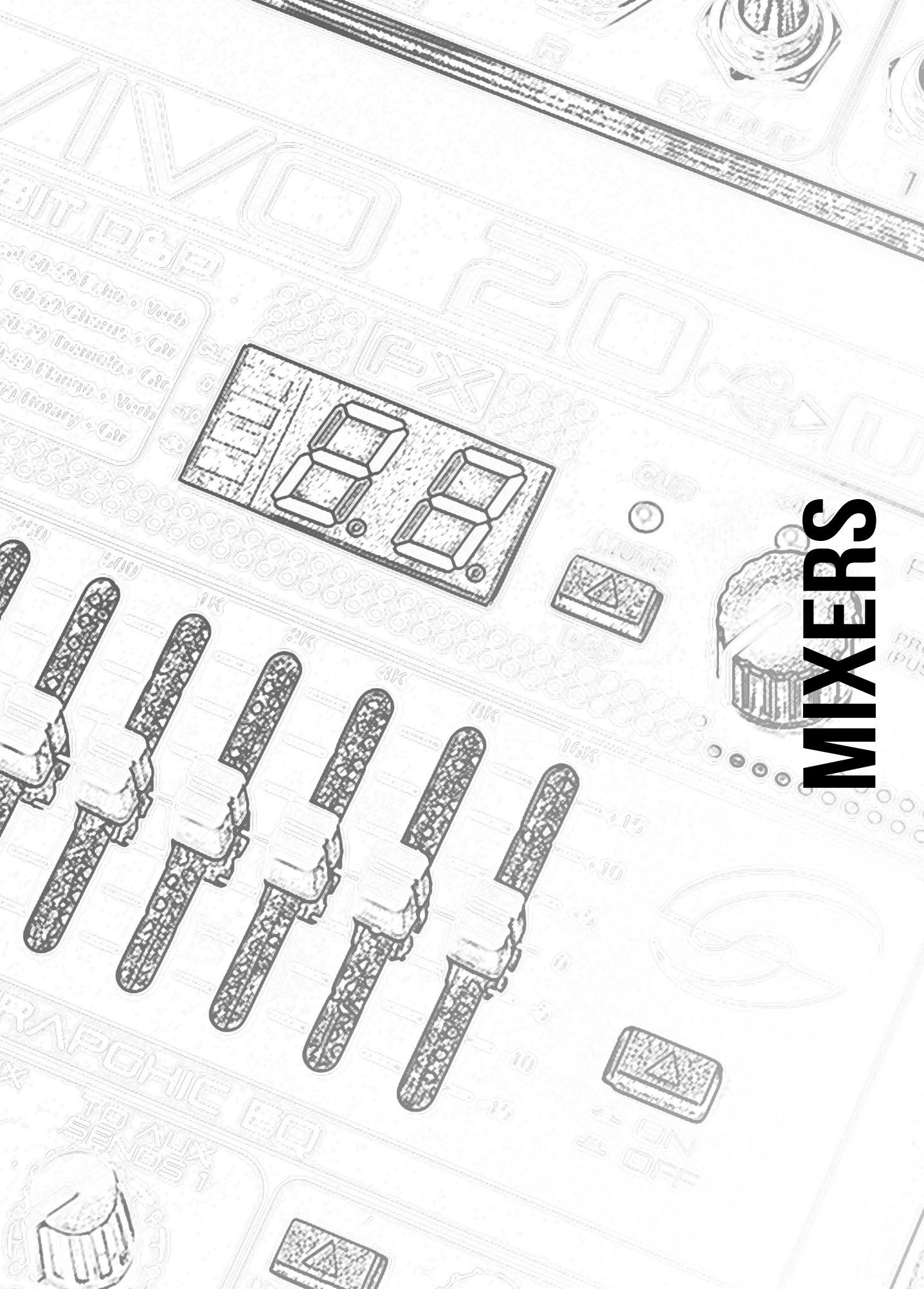

ALCHEMIX Series

ALCHEMIX 402FX - 8-Channel High Quality Mixer with 24-bit Digital Multi-Effect

AlcheMix mixer series has been designed to meet the requests of musicians and entertainment operators who need reliable and professional instruments for live shows, rehearsal rooms, schools, home recording, etc. The architecture of these 2-Bus mixers includes 2 subgroups, 2 AUX sends (one with Pre/Post-Fader selection; one Pre-Fader operation). All channels feature 3-band EQ, MUTE, AFL, Group and main assignments. A 7-band graphic EQ on the main outputs with precision filters, and a 48 kHz / 24-bit Digital Effect complete the set of tools of these mixers. The Digital Effect features 16 of the most used presets (Hall-Room-Plate reverb, Delay-Echo, and allow to customize one parameter through the Tap-Tempo button. The line consists of 4 models: AlcheMix 402FX, 402UFX, 602UFX and 802UFX with 4, 6 and 8 noiseless Mic/Line preamps. The 402-602-802UFX also feature a 2-In/2-Out USB Stereo Sound Card for recording/playback on PC/Mac at up to 96kHz/24-bit.

- 8 Total Channels
- 4 Mic/Line channels with wide-range gain noiseless preamps, XLR and balanced 1/4" Jack connectors, 75Hz Low-Cut filter, +48V Phantom Power, Signal/Peak Indicator
- 2 Stereo Line Channels with balanced 1/4" Jack inputs, with gain and Peak Indicator
- 3-Band EQ, Pan/Balance, Mute, PFL, Group 1-2, Main L-R, 60mm Volume Fader
- 2 AUX sends (1 with Pre/Post selection for internal DFX or AUX1 Out; 1 Pre-Fader for AUX2 Out) with channel/master level, AFL, and 1/4" Jack outputs
- Effect/AUX Return control with 60mm Fader, Mute, AFL, Group1-2, L-R assignment, and balanced 1/4" Jack inputs
- Group 1-2 XLR outputs with 60mm Fader, Mute, AFL, Master Left and Right assignment
- 7-Band Graphic EQ on Master Bus with precision filters
- 24-bit/48kHz 16-Preset Digital Effect with Footswitch Out, TAP-Tempo Button and up to 2 Adjustable Parameters for each Preset
- 2-Track In/Out RCA connections and Level control
- Headphones 1/4" Stereo Jack Out with Level control
- XLR Main Outputs with 60mm Fader Control and MUTE
- Stereo 12-Led VU Meter Bar for Main, PFL/AFL monitoring
- Stereo 1/4" Jack Monitor Output
- Rugged and Lightweight Metal Case

- Configuration: 4 Mic/Line + 2 Stereo
- Nominal Gain (Mic/Line/Stereo Line): 60dB, 40dB, 20dB
- Max Gain (Mic/Line/Stereo Line): 80dB, 60dB, 40dB
- Mic Input Sensitivity (Gain Min/Gain Max): -10dBu/-60dBu
- Line Input Sensitivity (Gain Min/Gain Max): +10dBu/-40dBu
- Stereo Line Input Sensitivity (Gain Min/Gain Max): +10dBu/-20dBu
- Aux Return Input Sensitivity: 0dBu / 2-Track In Input Sensitivity: -2dBu
- Mic/Line Max Input Level: +24dB
- Stereo Line/Aux/2-Track Max Input Level: +20dB
- Mic Input Impedance: 2kohm Balanced
- Line/Aux Input Impedance: 20kohm (Balanced)/10kohm (Unbalanced)
- Tape Record Inputs Input Impedance: 10kohm Balanced
- Main/Group/Monitor/Aux Output Levels: 0dBu (0.775V RMS) Nominal/ +22dBu (10V RMS) Max
- Record Out Output Levels: -2dB (600mv RMS)/ +22dBu (10V RMS) Max
- Main/Group/Monitor/Aux Send Output Impedance: 75ohm
- Record Output Impedance: 1kohm
- Phones Output Impedance: 33ohm min
- Frequency Response: 20Hz to 20kHz (+0/-2dB)
- Total Harmonic Distortion / Noise Ratio < 0.006% / < -85dB
- Mono MIC EQ (Treble/Mid/Bass): ±15dB (12kHz HF / 2.5 kHz MF/60Hz LF)
- Stereo Line EQ (Treble/Mid/Bass): ±15dB (12kHz HF / 2.5 kHz MF/80Hz LF)
- Effect: 16 Effects, 24-bit Sigma-Delta, 256-times oversampling, 48kHz sampling rate
- Phantom Power: +48V
- Power Supply: 150V-240V~50Hz, 15W max
- Size (WxDxH): 322 x 316.5 x 134 mm
- Net Weight: 4.5 kg



CODE	MSRP EUR	MSRP GBP
E527E	€229,57	£210.75

ALCHEMIX Series

ALCHEMIX 402 UFX - 8-Channel High Quality Mixer with 24-bit Digital Multi-Effect & USB Stereo In/Out Soundcard

AlcheMix mixer series has been designed to meet the requests of musicians and entertainment operators who need reliable and professional instruments for live shows, rehearsal rooms, schools, home recording, etc. The architecture of these 2-Bus mixers includes 2 subgroups, 2 AUX sends (one with Pre/Post-Fader selection; one Pre-Fader operation). All channels feature 3-band EQ, MUTE, AFL, Group and main assignments. A 7-band graphic EQ on the main outputs with precision filters, and a 48 kHz / 24-bit Digital Effect complete the set of tools of these mixers. The Digital Effect features 16 of the most used presets (Hall-Room-Plate reverb, Delay-Echo, and allow to customize one parameter through the Tap-Tempo button. The line consists of 4 models: AlcheMix 402FX, 402UFX, 602UFX and 802UFX with 4, 6 and 8 noiseless Mic/Line preamps. The 402-602-802UFX also feature a 2-In/2-Out USB Stereo Sound Card for recording/playback on PC/Mac at up to 96kHz/24-bit.

- 8 Total Channels
- 4 Mic/Line channels with wide-range gain noiseless preamps, XLR and balanced 1/4" Jack connectors, 75Hz Low-Cut filter, +48V Phantom Power, Signal/Peak Indicator
- 2 Stereo Line Channels with balanced 1/4" Jack inputs, with gain and Peak Indicator
- 3-Band EQ, Pan/Balance, Mute, PFL, Group 1-2, Main L-R, 60mm Volume Fader
- 2 AUX sends (1 with Pre/Post selection for internal DFX or AUX1 Out; 1 Pre-Fader for AUX2 Out) with channel/master level, AFL, and 1/4" Jack outputs
- Effect/AUX Return control with 60mm Fader, Mute, AFL, Group1-2, L-R assignment, and balanced 1/4" Jack inputs
- Group 1-2 XLR outputs with 60mm Fader, Mute, AFL, Master Left and Right assignment
- 7-Band Graphic EQ on Master Bus with precision filters
- 24-bit/48kHz 16-Preset Digital Effect with Footswitch Out, TAP-Tempo Button and up to 2 Adjustable Parameters for each Preset
- USB Stereo In/Out Sound Card with up to 96kHz/24-bit recording/playback capability
- 2-Track In/Out RCA connections and Level control
- Headphones 1/4" Stereo Jack Out with Level control
- XLR Main Outputs with 60mm Fader Control and MUTE
- Stereo 12-Led VU Meter Bar for Main, PFL/AFL monitoring
- Stereo 1/4" Jack Monitor Output
- Rugged and Lightweight Metal Case

- Configuration: 4 Mic/Line + 2 Stereo
- Nominal Gain (Mic/Line/Stereo Line): 60dB, 40dB, 20dB
- Max Gain (Mic/Line/Stereo Line): 80dB, 60dB, 40dB
- Mic Input Sensitivity (Gain Min/Gain Max): -10dBu/-60dBu
- Line Input Sensitivity (Gain Min/Gain Max): +10dBu/-40dBu
- Stereo Line Input Sensitivity (Gain Min/Gain Max): +10dBu/-20dBu
- Aux Return Input Sensitivity: 0dBu / 2-Track Input Sensitivity: -2dBu
- Mic/Line Max Input Level: +24dB
- Stereo Line/Aux/2-Track Max Input Level: +20dB
- Mic Input Impedance: 2kohm Balanced
- Line/Aux Input Impedance: 20kohm (Balanced)/10kohm (Unbalanced)
- Tape Record Inputs Impedance: 10kohm Balanced
- Main/Group/Monitor/Aux Send Output Levels: 0dBu (0.775V RMS) Nominal/ +22dBu (10V RMS) Max
- Record Out Output Levels: -2dB (600mv RMS)/ +22dBu (10V RMS) Max
- Main/Group/Monitor/Aux Send Output Impedance: 75ohm
- Record Output Impedance: 1kohm
- Phones Output Impedance: 33ohm min
- Frequency Response: 20Hz to 20kHz (+0/-2dB)
- Total Harmonic Distortion / Signal-Noise Ratio < 0.006% / < -85dB
- Mono MIC EQ (Treble/Mid/Bass): ±15dB (12kHz HF / 2.5 kHz MF/60Hz LF)
- Stereo Line EQ (Treble/Mid/Bass): ±15dB (12kHz HF / 2.5 kHz MF/80Hz LF)
- Effect: 16 Effects, 24-bit Sigma-Delta, 256-times oversampling, 48kHz sampling rate
- USB I/O Soundcard: Up to 24-bit/96kHz Stereo Input/Output Streaming, USB Class-2.0 compliant
- Phantom Power: +48V
- Power Supply: 150V-240V~50Hz, 15W max
- Size (WxDxH): 322 x 316.5 x 134 mm - Net Weight: 4.5 kg



CODE	MSRP EUR	MSRP GBP
E528E	€250,21	£229.69

ALCHEMIX Series

ALCHEMIX 602UFX - 10-Channel High Quality Mixer with 24-bit Digital Multi-Effect & USB Stereo In/Out Soundcard

AlcheMix mixer series has been designed to meet the requests of musicians and entertainment operators who need reliable and professional instruments for live shows, rehearsal rooms, schools, home recording, etc. The architecture of these 2-Bus mixers includes 2 subgroups, 2 AUX sends (one with Pre/Post-Fader selection; one Pre-Fader operation). All channels feature 3-band EQ, MUTE, AFL, Group and main assignments. A 7-band graphic EQ on the main outputs with precision filters, and a 48 kHz / 24-bit Digital Effect complete the set of tools of these mixers. The Digital Effect features 16 of the most used presets (Hall-Room-Plate reverb, Delay-Echo, and allow to customize one parameter through the Tap-Tempo button. The line consists of 4 models: AlcheMix 402FX, 402UFX, 602UFX and 802UFX with 4, 6 and 8 noiseless Mic/Line preamps. The 402-602-802UFX also feature a 2-In/2-Out USB Stereo Sound Card for recording/playback on PC/Mac at up to 96kHz/24-bit.

- 10 Total Channels
- 6 Mic/Line channels with wide-range gain noiseless preamps, XLR and balanced 1/4" Jack connectors, 75Hz Low-Cut filter, +48V Phantom Power, Signal/Peak Indicator
- 2 Stereo Line Channels with balanced 1/4" Jack inputs, with gain and Peak Indicator
- 3-Band EQ, Pan/Balance, Mute, PFL, Group 1-2, Main L-R, 60mm Volume Fader
- 2 AUX sends (1 with Pre/Post selection for internal DFX or AUX1 Out; 1 Pre-Fader for AUX2 Out) with channel/master level, AFL, and 1/4" Jack outputs
- Effect/AUX Return control with 60mm Fader, Mute, AFL, Group1-2, L-R assignment, and balanced 1/4" Jack inputs
- Group 1-2 XLR outputs with 60mm Fader, Mute, AFL, Master Left and Right assignment
- 7-Band Graphic EQ on Master Bus with precision filters
- 24-bit/48kHz 16-Preset Digital Effect with Footswitch Out, TAP-Tempo Button and up to 2 Adjustable Parameters for each Preset
- USB Stereo In/Out Sound Card with up to 96kHz/24-bit recording/playback capability
- 2-Track In/Out RCA connections and Level control
- Headphones 1/4" Stereo Jack Out with Level control
- XLR Main Outputs with 60mm Fader Control and MUTE
- Stereo 12-Led VU Meter Bar for Main, PFL/AFL monitoring
- Stereo 1/4" Jack Monitor Output
- Rugged and Lightweight Metal Case

- Configuration: 6 Mic/Line + 2 Stereo
- Nominal Gain (Mic/Line/Stereo Line): 60dB, 40dB, 20dB
- Max Gain (Mic/Line/Stereo Line): 80dB, 60dB, 40dB
- Mic Input Sensitivity (Gain Min/Gain Max): -10dBu/-60dBu
- Line Input Sensitivity (Gain Min/Gain Max): +10dBu/-40dBu
- Stereo Line Input Sensitivity (Gain Min/Gain Max): +10dBu/-20dBu
- Aux Return Input Sensitivity: 0dBu / 2-Track Input Sensitivity: -2dBu
- Mic/Line Max Input Level: +24dB
- Stereo Line/Aux/2-Track Max Input Level: +20dB
- Mic Input Impedance: 2kohm Balanced
- Line/Aux Input Impedance: 20kohm (Balanced)/10kohm (Unbalanced)
- Tape Record Inputs Impedance: 10kohm Balanced
- Main/Group/Monitor/Aux Send Output Levels: 0dBu (0.775V RMS) Nominal/ +22dBu (10V RMS) Max
- Record Out Output Levels: -2dB (600mv RMS)/ +22dBu (10V RMS) Max
- Main/Group/Monitor/Aux Send Output Impedance: 75ohm
- Record Output Impedance: 1kohm
- Phones Output Impedance: 33ohm min
- Frequency Response: 20Hz to 20kHz (+0/-2dB)
- Total Harmonic Distortion / Signal-Noise Ratio <0.006% / < -85dB
- Mono MIC (Treble/Mid/Bass): ±15dB (12kHz HF / 2.5 kHz MF/60Hz LF)
- Stereo Line (Treble/Mid/Bass): ±15dB (12kHz HF / 2.5 kHz MF/80Hz LF)
- Effect: 16 Effects, 24-bit Sigma-Delta, 256-times oversampling, 48kHz sampling rate
- USB I/O Soundcard: Up to 24-bit/96kHz Stereo Input/Output Streaming, USB Class-2.0 compliant
- Phantom Power: +48V
- Power Supply: 150V-240V~50Hz, 15W max
- Size (WxDxH): 376 x 316.5 x 134 mm - Net Weight: 5.0 kg



CODE	MSRP EUR	MSRP GBP
E529E	€277,58	£254.82

ALCHEMIX Series

ALCHEMIX 802UFX - 12-Channel High Quality Mixer with 24-bit Digital Multi-Effect & USB Stereo In/Out Soundcard

AlcheMix mixer series has been designed to meet the requests of musicians and entertainment operators who need reliable and professional instruments for live shows, rehearsal rooms, schools, home recording, etc. The architecture of these 2-Bus mixers includes 2 subgroups, 2 AUX sends (one with Pre/Post-Fader selection; one Pre-Fader operation). All channels feature 3-band EQ, MUTE, AFL, Group and main assignments. A 7-band graphic EQ on the main outputs with precision filters, and a 48 kHz / 24-bit Digital Effect complete the set of tools of these mixers. The Digital Effect features 16 of the most used presets (Hall-Room-Plate reverb, Delay-Echo, and allow to customize one parameter through the Tap-Tempo button. The line consists of 4 models: AlcheMix 402FX, 402UFX, 602UFX and 802UFX with 4, 6 and 8 noiseless Mic/Line preamps. The 402-602-802UFX also feature a 2-In/2-Out USB Stereo Sound Card for recording/playback on PC/Mac at up to 96kHz/24-bit.

- 12 Total Channels
- 8 Mic/Line channels with wide-range gain noiseless preamps, XLR and balanced 1/4" Jack connectors, 75Hz Low-Cut filter, +48V Phantom Power, Signal/Peak Indicator
- 2 Stereo Line Channels with balanced 1/4" Jack inputs, with gain and Peak Indicator
- 3-Band EQ, Pan/Balance, Mute, PFL, Group 1-2, Main L-R, 60mm Volume Fader
- 2 AUX sends (1 with Pre/Post selection for internal DFX or AUX1 Out; 1 Pre-Fader for AUX2 Out) with channel/master level, AFL, and 1/4" Jack outputs
- Effect/AUX Return control with 60mm Fader, Mute, AFL, Group1-2, L-R assignment, and balanced 1/4" Jack inputs
- Group 1-2 XLR outputs with 60mm Fader, Mute, AFL, Master Left and Right assignment
- 7-Band Graphic EQ on Master Bus with precision filters
- 24-bit/48kHz 16-Preset Digital Effect with Footswitch Out, TAP-Tempo Button and up to 2 Adjustable Parameters for each Preset
- USB Stereo In/Out Sound Card with up to 96kHz/24-bit recording/playback capability
- 2-Track In/Out RCA connections and Level control
- Headphones 1/4" Stereo Jack Out with Level control
- XLR Main Outputs with 60mm Fader Control and MUTE
- Stereo 12-Led VU Meter Bar for Main, PFL/AFL monitoring
- Stereo 1/4" Jack Monitor Output
- Rugged and Lightweight Metal Case

- Configuration: 8 Mic/Line + 2 Stereo
- Nominal Gain (Mic/Line/Stereo Line): 60dB, 40dB, 20dB
- Max Gain (Mic/Line/Stereo Line): 80dB, 60dB, 40dB
- Mic Input Sensitivity (Gain Min/Gain Max): -10dBu/-60dBu
- Line Input Sensitivity (Gain Min/Gain Max): +10dBu/-40dBu
- Stereo Line Input Sensitivity (Gain Min/Gain Max): +10dBu/-20dBu
- Aux Return Input Sensitivity: 0dBu / 2-Track Input Sensitivity: -2dBu
- Mic/Line Max Input Level: +24dB
- Stereo Line/Aux/2-Track Max Input Level: +20dB
- Mic Input Impedance: 2kohm Balanced
- Line/Aux Input Impedance: 20kohm (Balanced)/10kohm (Unbalanced)
- Tape Record Inputs Impedance: 10kohm Balanced
- Main/Group/Monitor/Aux Send Output Levels: 0dBu (0.775V RMS) Nominal/ +22dBu (10V RMS) Max
- Record Out Output Levels: -2dB (600mv RMS)/ +22dBu (10V RMS) Max
- Main/Group/Monitor/Aux Send Output Impedance: 75ohm
- Record Output Impedance: 1kohm
- Phones Output Impedance: 33ohm min
- Frequency Response: 20Hz to 20kHz (+0/-2dB)
- Total Harmonic Distortion / Signal-Noise Ratio <0.006% / < -85dB
- Mono MIC (Treble/Mid/Bass): ±15dB (12kHz HF / 2.5 kHz MF/60Hz LF)
- Stereo Line (Treble/Mid/Bass): ±15dB (12kHz HF / 2.5 kHz MF/80Hz LF)
- Effect: 16 Effects, 24-bit Sigma-Delta, 256-times oversampling, 48kHz sampling rate
- USB I/O Soundcard: Up to 24-bit/96kHz Stereo Input/Output Streaming, USB Class-2.0 compliant
- Phantom Power: +48V
- Power Supply: 150V-240V~50Hz, 15W max
- Size (WxDxH): 430 x 316.5 x 134 mm - Net Weight: 5.5 kg



CODE	MSRP EUR	MSRP GBP
E530E	€304,74	£279.75

YOUMIX Series

YOUMIX-202 MEDIA - 6-Channel Professional Mixer with Media Player, BT and Digital Multi Effect

YouMix series combines maximum portability with preamp quality, and filters and controls accuracy. The use of high quality SMD components allow us to concentrate functions that normally require much more space, such as the 60mm volume sliders, the SOLO function, a single display for both digital multi-effect and USB player, the BT connection. This series includes two models with 2 and 4 mic/line channels (plus 2 Line stereo inputs): YouMix-202 Media and YouMix-402 Media. They are ideal for live music, home recording, podcasting, and all those applications where you need to integrate all main functions of a professional mixing console into a single tool. The mic preamps offer high headroom and low noise, to guarantee a clean and natural sound with all source types: condenser microphones (with +48V Phantom Power), dynamic mics, line signals and high impedance instruments. The digital multi-effect offers 256 presets that cover all the most used effects (Room, Hall, Vocal, and Plate reverbs; Delay; Echo; Chorus; Flanger, and Combo). The USB player accepts files in MP3 format (up to 48kHz – 32-bit @ 320kbps); the BT receiver assures professional audio streaming. Both use one of the two stereo Line inputs and offer the advantage of in-line channel controls (Gain, 2-band EQ, FX Send, Pan and Solo). YouMix essentially represents the compact solution with superior performance to all those mixing requirements where the quality of the result cannot be secondary.

- 6-Channel Professional Mixing Console
- 2 Mic preamps with high-headroom & low-noise
- 2 Stereo channels and 1 separate stereo tape In/Out channel
- BT Stereo audio wireless connection with in-line channel controls
- USB Player with in-line channel controls
- 24-bit Digital Multi Effect with 256 Presets
- Balanced 1/4" (6.3mm) jacks on all Mic/Stereo Line channels
- Stereo Balanced Output with XLR; Stereo Control Room Outputs with 1/4" Jack
- 3-band EQ on all mono channels; 2-band EQ on stereo channels
- 60mm Volume slider on each channel and Main Output
- Aux/Eff Send controls on all channels
- Aux/Eff Return with 60mm slider for optimal level adjustment
- Control Room/Headphones output with dedicated volume control
- Built-in +48V phantom power for condenser microphones



- Input Connections: Balanced XLR (Mic Channels), Balanced 1/4" Jack (Mic and Stereo Line Channels), Stereo RCA (Tape In), USB 2.0 Type-A Jack (MP3 player)
- Output Connection: Balanced XLR (Main Out L-R), Unbalanced 1/4" Jack (Control Room L&R Out, Aux Send Out, Aux Return Input), Stereo 1/4" Jack (Phones), Stereo RCA (Tape Out)
- CH1-2 Mic Pre Type: Electronically balanced Preamps, discrete input configuration
- CH1-2 Mic Pre Frequency Response: 10Hz to 200kHz
- CH1-2 Mic Pre Gain range: +14dB to +60dB; SNR: 120dB E.I.N.
- CH1-2 Line input Type: Electronically balanced
- CH1-2 Line input Frequency Response: 10Hz to 130kHz
- CH1-2 Line input Gain range: -6dB to +38dB; SNR: 95dB E.I.N.
- CH1-2 3-Band EQ: Low Freq. 80Hz, +/-15dB; Mid Freq. 2.5kHz, +/-15dB
- CH1-2 Other Controls: Peak Led Indicator, Effect Send, Pan Position, Solo Button, 60mm Volume Slider, +48V Phantom Power (switch on rear panel)
- CH3-6 Stereo Mic/Line Pre Type: Electronically balanced
- CH3-6 Frequency response: 10Hz to 70kHz
- CH3-6 Gain range: Line: -8 to +15dB / Mic: +13 to +60dB
- CH3-6 SNR: Line: 96dB / Mic: 104dB E.I.N.
- CH3-6 2-Band EQ: Low Freq.; 80Hz, +/-15dB; Hi Freq.; 12kHz, +/-15dB
- CH3-6 Other Controls: Peak Led Indicator, Effect Send, Pan Position, Solo Button, 60mm Volume Slider, BT Pair button (CH3/4 only)
- Main Outputs: +28dB (balanced)
- Control Room Outputs, Aux Send/Return, Tape Out: +22dBu (unbalanced)
- Phones Output: +15dBu / 150ohm
- Main Section Controls: FX Return 60mm Level Slider, 60mm Main Level Slider, 60mm Phones/Control Room Volume Slider, Power On Led Indicator, Phantom On Led Indicator, 2x8 Led Vu Meter Bar (Main Level/Solo), 2x8 Character LCD Display (MP3 player and multieffect)
- MP3 Player Controls: USB Button, Parameter Dial/Push knob
- Player Functions: Music Player, EQ-Curve Selection, Player Mode, Audio Recording
- USB Drive Format: FAT32 format – max 32GByte
- Player/Recorder File Formats: MP3 (up to 48kHz @ 320kbps); WAV (32kHz/32bit)
- Digital Multi Effect: 24-bit Sigma-Delta, 256-times oversampling, 48kHz sampling rate, 256 Presets
- Power Requirement: 100-240Vac, 50/60Hz; Power Consumption: Max. 5W
- Size (WxDxH): 230 x 250 x 70 mm
- Net Weight: 1.85kg

CODE	MSRP EUR	MSRP GBP
E525E	€181,25	£166.39

YOUMIX Series

YOUMIX-402 MEDIA - 8-Channel Professional Mixer with Media Player, BT and Digital Multi Effect

YouMix series combines maximum portability with preamp quality, and filters and controls accuracy. The use of high quality SMD components allow us to concentrate functions that normally require much more space, such as the 60mm volume sliders, the SOLO function, a single display for both digital multi-effect and USB player, the BT connection. This series includes two models with 2 and 4 mic/line channels (plus 2 Line stereo inputs): YouMix-202 Media and YouMix-402 Media. They are ideal for live music, home recording, podcasting, and all those applications where you need to integrate all main functions of a professional mixing console into a single tool. The mic preamps offer high headroom and low noise, to guarantee a clean and natural sound with all source types: condenser microphones (with +48V Phantom Power), dynamic mics, line signals and high impedance instruments. The digital multi-effect offers 256 presets that cover all the most used effects (Room, Hall, Vocal, and Plate reverbs; Delay; Echo; Chorus; Flanger, and Combo). The USB player accepts files in MP3 format (up to 48kHz – 32-bit @ 320kbps); the BT receiver assures professional audio streaming. Both use one of the two stereo Line inputs and offer the advantage of in-line channel controls (Gain, 2-band EQ, FX Send, Pan and Solo). YouMix essentially represents the compact solution with superior performance to all those mixing requirements where the quality of the result cannot be secondary.

- 8-Channel Professional Mixing Console
- 4 Mic preamps with high-headroom & low-noise
- 2 Stereo channels and 1 separate stereo tape In/Out channel
- BT Stereo audio wireless connection with in-line channel controls
- USB Player with in-line channel controls
- 24-bit Digital Multi Effect with 256 Presets
- Balanced 1/4" (6.3mm) jacks on all Mic/Stereo Line channels
- Stereo Balanced Output with XLR; Stereo Control Room Outputs with 1/4" Jack
- 3-band EQ on all mono channels; 2-band EQ on stereo channels
- 60mm Volume slider on each channel and Main Output
- Aux/Eff Send controls on all channels
- Aux/Eff Return with 60mm slider for optimal level adjustment
- Control Room/Headphones output with dedicated volume control
- Built-in +48V phantom power for condenser microphones



- Input Connections: Balanced XLR (Mic Channels), Balanced 1/4" Jack (Mic and Stereo Line Channels), Stereo RCA (Tape In), USB 2.0 Type-A Jack (MP3 player)
- Output Connection: Balanced XLR (Main Out L-R), Unbalanced 1/4" Jack (Control Room L&R Out, Aux Send Out, Aux Return Input), Stereo 1/4" Jack (Phones), Stereo RCA (Tape Out)
- CH1-4 Mic Pre Type: Electronically balanced Preamps, discrete input configuration
- CH1-4 Mic Pre Frequency Response: 10Hz to 200kHz
- CH1-4 Mic Pre Gain range: +14dB to +60dB; SNR: 120dB E.I.N.
- CH1-4 Line input Type: Electronically balanced
- CH1-4 Line input Frequency Response: 10Hz to 130kHz
- CH1-4 Line input Gain range: -6dB to +38dB; SNR: 95dB E.I.N.
- CH1-4 3-Band EQ: Low Freq. 80Hz, +/-15dB; Mid Freq. 2.5kHz, +/-15dB; Hi Freq. 12kHz, +/-15dB
- CH1-4 Other Controls: Peak Led Indicator, Effect Send, Pan Position, Solo Button, 60mm Volume Slider, +48V Phantom Power (switch on rear panel)
- CH5-8 Stereo Mic/Line Pre Type: Electronically balanced
- CH5-8 Frequency response: 10Hz to 70kHz
- CH5-8 Gain range: Line: -8 to +15dB / Mic: +13 to +60dB
- CH5-8 SNR: Line: 96dB / Mic: 104dB E.I.N.
- CH5-8 2-Band EQ: Low Freq.; 80Hz, +/-15dB; Hi Freq.; 12kHz, +/-15dB
- CH5-8 Other Controls: Peak Led Indicator, Effect Send, Pan Position, Solo Button, 60mm Volume Slider, BT Pair button (CH5/6 only)
- Main Outputs: +28dB (balanced)
- Control Room Outputs, Aux Send/Return, Tape Out: +22dBu (unbalanced)
- Phones Output: +15dBu / 150ohm
- Main Section Controls: FX Return 60mm Level Slider, 60mm Main Level Slider, 60mm Phones/Control Room Volume Slider, Power On Led Indicator, Phantom On Led Indicator, 2x8 Led Vu Meter Bar (Main Level/Solo), 2x8 Character LCD Display (MP3 player and multieffect)
- MP3 Player Controls: USB Button, Parameter Dial/Push knob
- Player Functions: Music Player, EQ-Curve Selection, Player Mode, Audio Recording
- USB Drive Format: FAT32 format – max 32GByte
- Player/Recorder File Formats: MP3 (up to 48kHz @ 320kbps); WAV (32kHz/32bit)
- Digital Multi Effect: 24-bit Sigma-Delta, 256-times oversampling, 48kHz sampling rate, 256 Presets
- Power Requirement: 100-240Vac, 50/60Hz; Power Consumption: Max. 5W
- Size (WxDxH): mm - Net Weight: kg

CODE	MSRP EUR	MSRP GBP
E526E	€205,97	£189.08

MIOMIX Series

MIOMIX 104 - 5-Channel Professional Audio Mixer with Digital Echo Effect

MioMix 104 is a 5-channel mixer ideal for small home recording, live gigs and Podcasting applications that require professional quality level and maximum portability. The Mic input is equipped with a noise-less preamp, able to manage all main sound sources, such as condenser microphones - thanks to the +48V Phantom Power, dynamic mics, line and high-impedance inputs (guitars, basses, etc.). The stereo line inputs allow you to connect keyboards, CD players, DJ consoles, tablets, smartphones, etc. The professional echo digital effect enriches your performance by allowing you to adjust speed and number of repetitions. An indispensable and reliable tool for all small audio applications.

- 5 Total Channels
- 1 Mic/Line channel with noiseless preamp, combo connector, Hi-Z input for guitars, +48V Phantom Power, Peak Indicator
- 1 Stereo Line Channel with 1/4" Jack inputs, +4/-10dB Pad Adapter and Peak Indicator
- 1 Stereo Line Channel with RCA and 1/8" Stereo Mini-Jack
- 2-Band EQ on channels from 1 to 3
- Digital Echo Effect with Repetition, Delay and Level adjustment
- Headphone monitor out with level control
- XLR Main Outputs with Master Level Control
- Stereo 6-Led VU Meter Bar
- Rugged and Lightweight Metal Case for Maximum Flexibility and Portability



- Input Connections: Balanced XLR/Jack Combo (Channel 1). Balanced 1/4" Jack (Channel 2-3). Stereo RCA, Stereo 1/8" Mini-Jack (Channel 4-5)
- Output Connection: Balanced XLR (Main Out L-R), Stereo 1/4" Jack (Phones)
- Channel 1 Functions: +48V Phantom Power, Impedance switch (Line/Hi-Z), 2-Band EQ (80Hz/12kHz +/-15dB), Effect Send Level, Pan Position, Channel Volume, Peak Led Indicator
- Channel 2-3 Functions: Impedance switch (+4/-10dB), 2-Band EQ (80Hz/12kHz +/-15dB), Effect Send Level, Pan Position, Channel Volume, Peak Led Indicator
- Channel 4-5 Functions: Pan Position, Channel Volume
- Effect Functions: Echo Repetition Adjustment, Echo Delay Time Adjustment, Echo Level Adjustment
- Level Meter: 2x6 LED Meter
- Max Output Level: 3 Vrms
- Frequency Response: +/-0.5dB, 20Hz-20kHz
- Dynamic Range: 102dB
- THD+N @ 1kHz: =0.003%
- Stereo Crosstalk: 92dB
- Power Requirements: DC 5V, 0.5A
- Power Consumption: Max. 2.5W
- Net Weight: 0.89kg

CODE	MSRP EUR	MSRP GBP
E918E	€63,47	£58.27

MIOMIX 202M - 4-Channel Professional Audio Mixer with Media Player, BT & Digital Echo Effect

MioMix 202M is a 4-channel mixer with USB player ideal for small home recording, live gigs and podcasting applications that require professional quality level and maximum portability. Two Mic inputs are equipped with noise-less preamps that accepts all main sound sources, such as condenser microphones - thanks to the +48V Phantom Power, dynamic mics, line and high-impedance inputs (guitars, basses, etc.). A stereo line input allow you to connect keyboards, CD players, DJ consoles, tablets, smartphones, etc. The USB & BT player accepts WAV, MP3, WMA and FLAC format audio files, as well as wireless audio streaming (BT). It also records your gig in MP3 format (48kHz/16bit @ 128Kbps). The professional echo digital effect enriches your performance by allowing you to adjust speed and number of repetitions. An indispensable and reliable tool for all small audio applications.

- 4 Total Channels
- 2 Mic/Line channels with noiseless preamp, combo connector, Hi-Z input for guitars, +48V Phantom Power, Peak Indicator
- 1 Stereo Line Channel with 1/4" Jack inputs, +4/-10dB Pad Adapter and Peak Indicator
- USB Media Player and Recorder (WAV, MP3, WMA, FLAC and BT wireless audio streaming)
- 2-Band EQ for channels 1 and 2
- Digital Echo Effect with Repetition, Delay and Level adjustment
- Media Player output level control
- Headphone monitor out with level control
- XLR Main Outputs with Master Level Control
- Stereo 6-Led VU Meter Bar
- Rugged and Lightweight Metal Case for Maximum Flexibility and Portability



- Input Connections: Balanced XLR/Jack Combo (Channel 1-2), Balanced 1/4" Jack (Channel 3-4)
- Output Connection: Balanced XLR (Main Out L-R), Stereo 1/4" Jack (Phones)
- Channel 1-2 Functions: +48V Phantom Power, Impedance switch (Line/Hi-Z), 2-Band EQ (80Hz/12kHz +/-15dB), Effect Send Level, Pan Position, Channel Volume, Peak Led Indicator
- Channel 3-4 Functions: Impedance switch (+4/-10dB), 2-Band EQ (80Hz/12kHz +/-15dB), Effect Send Level, Pan Position, Channel Volume, Peak Led Indicator
- USB Player Buttons: Up/Rewind, Down/Forward, Play/Pause/Enter, Menu
- USB Player Functions: BT streaming, Music Player, Audio Recording, EQ-Curve Selection
- USB Drive Format: FAT32 format - max 64GByte
- Player File Formats: WAV, MP3, WMA, FLAC e streaming audio wireless BT
- Recorder File Format: MP3 (48kHz/16bit @ 128Kbps)
- Effect Functions: Echo Repetition Adjustment, Echo Delay Time Adjustment, Echo Level Adjustment
- Level Meter: 2x6 LED Meter
- Max Output Level: 3 Vrms
- Frequency Response: +/-0.5dB, 20Hz-20kHz
- Dynamic Range: 102dB
- THD+N @ 1kHz: =0.003%
- Stereo Crosstalk: 92dB
- Power Requirements: DC 5V, 0.5A
- Power Consumption: Max. 2.5W
- Size (WxDxH): 166 x 165 x 66 mm - Net Weight: 0.9 kg

CODE	MSRP EUR	MSRP GBP
E919E	€85,18	£78.20

MIOMIX Series

MIOMIX 202UFX - 4-Channel Professional Audio Mixer with Digital Multi-Effect & up to 24-bit/96kHz USB I/O Soundcard

MioMix 202UFX is a 4-channel mixer with digital multi-effect and USB soundcard ideal for small home recording, live gigs and podcasting applications that require professional quality level and maximum portability. Two Mic inputs are equipped with noise-less preamps that accepts all main sound sources, such as condenser microphones - thanks to the +48V Phantom Power, dynamic mics, line and high-impedance inputs (guitars, basses, etc.). A stereo line input allow you to connect keyboards, CD players, DJ consoles, tablets, smartphones, etc. The 24-bit/48kHz digital effect with 16 commonly used presets (Hall/Room/Plate Reverb, Delay, Echo, Chorus, etc.) and TAP-Tempo function let you improve your performance and adjust up to two parameters of each effect. The USB 24-bit/96kHz Stereo In/Out Soundcard lets you connect to a computer and record or play top-quality audio files. An indispensable and reliable tool for all small audio applications.

- 4 Total Channels
- 2 Mic/Line channels with noiseless preamp, combo connector, Hi-Z input for guitars, +48V Phantom Power, Peak Indicator
- 1 Stereo Line Channel with 1/4" Jack inputs, +4/-10dB Pad Adapter and Peak Indicator
- 2-Band EQ for channels 1 and 2
- 24-bit/48kHz 16-Preset Digital Effect with TAP-Tempo and up to 2 adjustable Parameters
- 24-bit/96kHz USB I/O Stereo Soundcard with Playback Level Control
- Headphone monitor out with level control
- XLR Main Outputs with Master Level Control
- Stereo 6-Led VU Meter Bar
- Rugged and Lightweight Metal Case for Maximum Flexibility and Portability
- 240Vac - 5Vdc Power Adapter included



- Input Connections: Balanced XLR/Jack Combo (Channel 1-2), Balanced 1/4" Jack (Channel 3-4)
- Output Connection: Balanced XLR (Main Out L-R), Stereo 1/4" Jack (Phones)
- USB Connection: Type-B, Female
- Channel 1-2 Functions: +48V Phantom Power, Impedance switch (Line/Hi-Z), 2-Band EQ (80Hz/12kHz +/-15dB) Effect Send Level, Pan Position, Channel Volume, Peak Led Indicator
- Channel 3-4 Functions: Impedance switch (+4/-10dB), 2-Band EQ (80Hz/12kHz +/-15dB), Effect Send Level, Pan Position, Channel Volume, Peak Led Indicator
- USB I/O Soundcard: Up to 24-bit/96kHz Stereo Input/Output Streaming, USB Class-2.0 compliant
- Digital Effect: 24-bit Sigma-Delta, 256-times oversampling, 48kHz sampling rate
- Level Meter: 2x6 LED Meter
- Max Output Level: 3 Vrms
- Frequency Response: +/-0.5dB, 20Hz-20kHz
- Dynamic Range: 102dB
- THD+N @ 1kHz: =0.003%
- Stereo Crosstalk: 92dB
- Power Requirements: DC 5V, 0.5A
- Power Consumption: Max. 2.5W
- Power Adapter: 100-240Vac - 0.15A / 5Vcc - 1A Max (Power Adapter Included)
- Size (WxDxH): 166 x 165 x 66 mm - Net Weight: 0.9kg

CODE	MSRP EUR	MSRP GBP
E920E	€130,27	£119.59

MIOMIX 204FX - 6-Channel Professional Audio Mixer with 24-bit Digital Multi-Effect

MioMix 204FX is a 6-channel mixer with digital multi-effect ideal for small home recording, live gigs and podcasting applications that require professional quality level and maximum portability. Two Mic inputs are equipped with noise-less preamps that accepts all main sound sources, such as condenser microphones - thanks to the +48V Phantom Power, dynamic mics, line and high-impedance inputs (guitars, basses, etc.). The stereo line inputs allow you to connect keyboards, CD players, DJ consoles, tablets, smartphones, etc. The 24-bit/48kHz digital effect with 16 commonly used presets (Hall/Room/Plate Reverb, Delay, Echo, Chorus, etc.) and TAP-Tempo function let you improve your performance and adjust up to two parameters of each effect. An indispensable and reliable tool for all small audio applications.

- 6 Total Channels
- 2 Mic/Line channels with noiseless preamp, combo connector, Hi-Z input for guitars, +48V Phantom Power, Peak Indicator
- 1 Stereo Line Channel with 1/4" Jack inputs, +4/-10dB Pad Adapter and Peak Indicator
- 1 Stereo Line Channel with RCA and 1/8" Stereo Mini-Jack
- 2-Band EQ for channels 1 and 2
- 24-bit/48kHz 16-Preset Digital Effect with TAP-Tempo and up to 2 adjustable Parameters
- Headphone monitor out with level control
- XLR Main Outputs with Master Level Control
- Stereo 6-Led VU Meter Bar
- Rugged and Lightweight Metal Case for Maximum Flexibility and Portability



- Input Connections: Balanced XLR/Jack Combo (Channel 1-2), Balanced 1/4" Jack (Channel 3-4), Stereo RCA, Stereo 1/8" Mini-Jack (Channel 5-6)
- Output Connection: Balanced XLR (Main Out L-R), Stereo 1/4" Jack (Phones)
- Channel 1-2 Functions: +48V Phantom Power, Impedance switch (Line/Hi-Z), 2-Band EQ (80Hz/12kHz +/-15dB), Effect Send Level, Pan Position, Channel Volume, Peak Led Indicator
- Channel 3-4 Functions: Impedance switch (+4/-10dB), Pan Position, Channel Volume, Peak Led Indicator
- Channel 5-6 Functions: Channel Volume, Mono/Stereo Switch
- Digital Effect: 24-bit Sigma-Delta, 256-times oversampling, 48kHz sampling rate
- Level Meter: 2x6 LED Meter
- Max Output Level: 3 Vrms
- Frequency Response: +/-0.5dB, 20Hz-20kHz
- Dynamic Range: 102dB
- THD+N @ 1kHz: =0.003%
- Stereo Crosstalk: 92dB
- Power Requirements: DC 5V, 0.5A
- Power Consumption: Max. 2.5W
- Size (WxDxH): 166 x 165 x 66 mm - Net Weight: 0.9kg

CODE	MSRP EUR	MSRP GBP
E921E	€106,89	£98.13

MIOMIX Series

MIOMIX 404FX - 8-Channel Professional Audio Mixer with 24-bit Digital Multi-Effect

MioMix 404FX is a 8-channel mixer with digital multi-effect ideal for small home recording, live gigs and podcasting applications that require professional quality level and maximum portability. 4 Mic inputs are equipped with noise-less preamps that accepts all main sound sources, such as condenser microphones - thanks to the +48V Phantom Power, dynamic mics, line and high-impedance inputs (guitars, basses, etc.). The stereo line inputs allow you to connect keyboards, CD players, DJ consoles, tablets, smartphones, etc. The 24-bit/48kHz digital effect with 16 commonly used presets (Hall/Room/Plate Reverb, Delay, Echo, Chorus, etc.) and TAP-Tempo function let you improve your performance and adjust up to two parameters of each effect. An indispensable and reliable tool for all small audio applications.

- 8 Total Channels
- 4 Mic/Line channels with noiseless preamp, combo connector, Hi-Z input for guitars, +48V Phantom Power, Peak Indicator
- 1 Stereo Line Channel with 1/4" Jack inputs, +4/-10dB Pad Adapter and Peak Indicator
- 1 Stereo Line Channel with RCA and 1/8" Stereo Mini-Jack
- 2-Band EQ for channels 1 to 4
- 24-bit/48kHz 16-Preset Digital Effect with TAP-Tempo and up to 2 adjustable Parameters
- Headphone monitor out with level control
- XLR Main Outputs with Master Level Control
- Stereo 6-Led VU Meter Bar
- Rugged and Lightweight Metal Case for Maximum Flexibility and Portability

- Input Connections: Balanced XLR/Jack Combo (Channel 1-4), Balanced 1/4" Jack (Channel 5-6), Stereo RCA, Stereo 1/8" Mini-Jack (Channel 7-8)
- Output Connection: Balanced XLR (Main Out L-R), Stereo 1/4" Jack (Phones)
- Channel 1-4 Functions: +48V Phantom Power, Impedance switch (Line/Hi-Z), 2-Band EQ (80Hz/12kHz +/-15dB), Effect Send Level, Pan Position, Channel Volume, Peak Led Indicator
- Channel 5-6 Functions: Impedance switch (+4/-10dB), Pan Position, Channel Volume, Peak Led Indicator
- Channel 7-8 Functions: Channel Volume, Mono/Stereo Switch
- Digital Effect: 24-bit Sigma-Delta, 256-times oversampling, 48kHz sampling rate
- Level Meter: 2x6 LED Meter
- Max Output Level: 3 Vrms
- Frequency Response: +/-0.5dB, 20Hz-20kHz
- Dynamic Range: 102dB
- THD+N @ 1kHz: =0.003%
- Stereo Crosstalk: 92dB
- Power Requirements: DC 5V, 0.5A
- Power Consumption: Max. 2.5W
- Size (WxDxH): 220 x 165 x 66 mm - Net Weight: 1.2kg



CODE	MSRP EUR	MSRP GBP
E922E	€128,50	£117.96

MIOMIX Series

MIOMIX 404FXM - 6-Channel Professional Audio Mixer with Media Player, BT & 24-bit Digital Multi-Effect

MioMix 404FXM is a 6-channel mixer with USB player and digital multi-effect ideal for small home recording, live gigs and podcasting applications that require professional quality level and maximum portability. 4 Mic inputs are equipped with noise-less preamps that accepts all main sound sources, such as condenser microphones - thanks to the +48V Phantom Power, dynamic mics, line and high-impedance inputs (guitars, basses, etc.). The stereo line input allow you to connect keyboards, CD players, DJ consoles, tablets, smartphones, etc. The USB & BT player accepts WAV, MP3, WMA and FLAC format audio files, as well as wireless audio streaming (BT). It also records your gig in MP3 format (48kHz/16bit @ 128Kbps). The 24-bit/48kHz digital effect with 16 commonly used presets (Hall/Room/Plate Reverb, Delay, Echo, Chorus, etc.) and TAP-Tempo function let you improve your performance and adjust up to two parameters of each effect. An indispensable and reliable tool for all small audio applications.

- 6 Total Channels
- 4 Mic/Line channels with noiseless preamp, combo connector, Hi-Z input for guitars, +48V Phantom Power, Peak Indicator
- 1 Stereo Line Channel with 1/4" Jack inputs, +4/-10dB Pad Adapter and Peak Indicator
- USB Media Player and Recorder (WAV, MP3, WMA, FLAC and BT wireless audio streaming)
- 2-Band EQ for channels 1 to 4
- 24-bit/48kHz 16-Preset Digital Effect with TAP-Tempo and up to 2 adjustable Parameters
- Media Player output level control
- Headphone monitor out with level control
- XLR Main Outputs with Master Level Control
- Stereo 6-Led VU Meter Bar
- Rugged and Lightweight Metal Case for Maximum Flexibility and Portability

- Input Connections: Balanced XLR/Jack Combo (Channel 1-4), Balanced 1/4" Jack (Channel 5-6)
- Output Connection: Balanced XLR (Main Out L-R), Stereo 1/4" Jack (Phones), Stereo RCA (Rec Out)
- Channel 1-4 Functions: +48V Phantom Power, Impedance switch (Line/Hi-Z), 2-Band EQ (80Hz/12kHz +/-15dB), Effect Send Level, Pan Position, Channel Volume, Peak Led Indicator
- Channel 5-6 Functions: Impedance switch (+4/-10dB), Pan Position, Channel Volume, Peak Led Indicator
- USB Player Buttons: Up/Rewind, Down/Forward, Play/Pause/Enter, Menu
- USB Player Functions: BT streaming, Music Player, Audio Recording, EQ-Curve Selection
- USB Drive Format: FAT32 format - max 64GByte
- Player File Formats: WAV, MP3, WMA, FLAC e streaming audio wireless BT
- Recorder File Format: MP3 (48kHz/16bit @ 128Kbps)
- Digital Effect: 24-bit Sigma-Delta, 256-times oversampling, 48kHz sampling rate
- Level Meter: 2x6 LED Meter
- Max Output Level: 3 Vrms
- Frequency Response: +/-0.5dB, 20Hz-20kHz
- Dynamic Range: 102dB
- THD+N @ 1kHz: =0.003%
- Stereo Crosstalk: 92dB
- Power Requirements: DC 5V, 0.5A
- Power Consumption: Max. 2.5W
- Size (WxDxH): 220 x 165 x 66 mm - Net Weight: 1.2kg



CODE	MSRP EUR	MSRP GBP
E923E	€146,97	£134.92

VIVO Series

VIVO-24UFX MKII - 24 channels High quality Professional mixer with Ambient Pro® FX processor and USB I/O soundcard

VIVO 24 MKII is a professional mixing console studied both for Live and Studio. The new MKII version is equipped with Ambient Pro® high quality DSP. The 24 inputs cover a wide range of application and their noise-less pre-amp ensure an excellent S/N ratio. All the components are top quality starting from the 80mm channel faders that prevents any possible noise during the volume regulation. VIVO features 4 AUX sends with relative RETURNS as well as 4 SUB-Groups useful for the routing of more channels to an external device or to the MAIN. The Master section has a 12 segment VU Meter with Clip indicator and 2 knobs to adjust the levels of the Headphone Out and the Control Room out. The ultra-rugged construction allows to use this workstation in the open air with any weather condition. Using the 2.0 USB Out is possible to record in real time in any DAW becoming a powerful resource in Recording Studio.

- 24 total inputs
- 16 mono channel, 4 stereo channels, 4 Sub-groups
- 18 noiseless Mic preamp with +48v phantom power, gain control and lo-cut filter
- Balanced inputs for low noise and signal integrity
- 2 AUX Sends (Pre or Post) and 2 FX sends (4 total independent sends)
- 3 band Eq with parametric filter on Mid Frequencies
- 24 bit digital Multi Effect Ambient Pro® Processor with 100 programs
- 2 Track-in assignable to MAIN
- Adjustable Headphone monitor out and Control Room Out
- 9 band Graphic Eq on Master Out
- Clip Led indicator and mute/solo function on each channel, 12 segment VU Meter on Master Out
- Low latency USB I/O soundcard with USB input assignable to channel
- Routing of each channel on MAIN, SUB 1-2, SUB 3-4 or SOLO mode
- Rugged metal case for Live shows in the open air
- High quality and precise 80 mm faders

- Power Supply: 100 -240 V~, 50/60 Hz
- Mains connection: Standard IEC receptacle
- Fuse: 100 -240 V~, T 1.6 A L 250V
- Frequency response: 10Hz - 55 kHz +/- 3 dB
- THD+N: 0.0005% @ +4dBu, 1 kHz
- S/N Ratio: 115 dB
- Sensitivity range: from +15 dBu to -35 dBu
- DSP effect: A/D and D/A with 24 bit sample ratio
- MIC input impedance: 1,4 KOhm
- INSERT impedance: 2,5 KOhm
- All other inputs impedance: >10KOhm
- LO-CUT filter: 75 Hz, 18 dB/oct.
- HI filter: +/- 15 dB @ 12KHz
- MID filter: +/- 15 dB frequency response 100Hz-8kHz
- LO filter: +/- 15 dB @ 80 Hz
- HI-MID and LO-MID filter (Stereo Channels): +/- 15 dB @3kHz and +/- 15 dB @ 500 Hz
- Dimensions (H x W x D): 105mm x 755mm x 445 mm
- Weight: 10,4 Kg

CODE	MSRP EUR	MSRP GBP
L332L	€713,95	£655.41



PMX-4BT - 6-channels 200+200W max. powered mixer with effects, MP3 and BT

PMX-4BT is designed to be a powerful resource for live and educational purposes. The friendly user interface is one of the best features of this product and allows you to configure your sound device in a fast and easy way. The 6-Channel Active Mixer lets you plug microphones, instruments or any other audio equipment thanks to the XLR inputs on channel 1-4, the 1/4" Jack inputs on channel 1-3, the stereo RCA inputs on channel 4 and the 3mm jack input on channel 5/6 that allows you to plug in a computer, a smartphone, a tablet, etc. Each channel features a 2-Band EQ to better tune each channel. You can also use the 3-band EQ on the master section in order to adjust the overall sound to the characteristics of the environment in which you're going to use the unit. The system is equipped with a built-in effect with level adjustment on channels 1-4, and you can adjust master effect level, time duration and number of repeats in the FX Section. Finally, the multimedia player with remote control reads MP3 files from the USB connector, the SD-Card slot, and the BT connection, displaying all playback information through the wide LCD display.

- 6-Channel 200+200W powered mixer with effect and multimedia player
- 4 Mic/Line channel (CH1-4) with independent 2-band EQ and FX send bus with adjustable level
- 1 stereo channel (CH5-6) with 3mm Jack connector for tablets, computers and other multimedia devices
- 3-Band EQ on Master outputs
- Effect with Level, Delay Time and Repeat adjustment
- RCA Stereo TAPE In/Out for an external recorder/player
- MP3 player with remote control for USB, SD-Card devices and BT connection
- Impact-resistant wooden enclosure with practical handle for easy transport

- System Type: Active Mixer with MP3 and BT Player
- Rated Power: 100+100W @ 4ohm
- Peak Power: 200+200W @ 4ohm
- Frequency Range: 20Hz - 20KHz +/-3dB @ 1W
- Mixer: 6-Channel Inputs (4 x Mono /Line, 1 x Stereo Line)
- Input Impedance: Mic - 2Kohm (balanced) / 1kohm (unbalanced); Line - 10kohm / Tape IN - 47Kohm
- Input Channel EQ: HIGH +/-15dB @ 12kHz; LOW +/-15dB @ 80Hz
- 3-Band EQ: Bass - Mid- Treble for Master Section
- Stereo Monitor Out: 1/4" Stereo Jack (TRS)
- Speaker Outputs: 2x 1/4" Mono Jack (TS)
- Effect: Eco with Adjustable Level, Time and Repeat
- Digital Delay Time: 140 - 342ms
- Digital Player: USB (MS-DOS® FAT-32 format, max 32GByte), SD-Card (MS-DOS® FAT-32 format, max 32GByte), Bluetooth®, LCD Display, Remote Control
- AC Input: 230 V - 50Hz
- Fuse: T2A 250V
- Unit Size: 470 x 225 x 130 mm - 18.50 x 8.59 x 5.19 in
- Unit Weight: 7.2 Kg - 15.87 lbs.

CODE	MSRP EUR	MSRP GBP
J689J	€203,72	£187.01



PMX Series

PMX-8UBT - 8-channels 300W max. powered mixer with Bluetooth™, effects and MP3 player

PMX-8UBT is the ideal tool for all those small bands or musicians who need a mixer with quality Mic. preamps with +48V phantom power, a digital processor with 16 useful effects, an MP3 player with USB port and a dual amplification line for both FOH and stage monitoring with a 7-band EQ for each of them. Its size and lightweight combined with robust construction makes it extremely portable and stage-resistant.

- 300+300W peak power amplification
- 8-channel mixer with 2-band EQ, FX send, Gain, Pan and Level for each channel
- Premium Mic. Preamps with Low-impedance XLR and High-impedance 1/4" Jack connectors
- +48V Phantom Power switchable on all XLR inputs for the use with condenser microphones
- Digital effect with 16 among most used presets
- Stereo TAPE In/Out for recording or playing audio to/from recorders, sound cards or other equipment
- Two 7-band graphic EQ for respectively main and monitor outputs
- MP3 player with wide LCD display and USB input for mass storage devices up to 32GB
- Bluetooth™ connection for stereo playback of smartphones, tablets, etc.
- Lightweight and impact-resistant ABS enclosure with practical handle on one side for easy transport



- Peak Power: 300+300W @ 4ohm
- RMS Power: 150+150W @ 4ohm
- HI-Z/LIne Input Impedance: 2.2Kohm
- LO-Z Input Impedance/Mic: 600ohm
- Frequency Response: 20Hz - 20KHz, +1dB/-3dB @ 1W
- EQ HIGH: +/- 12 dB @ 12 kHz
- EQ LOW: +/-12 dB @ 80 Hz
- 7-Band Graphic EQ: +/- 12 dB @ 60, 120, 360, 1k, 2.5k, 7k, 16kHz
- Harmonic Distortion (THD): <0.3% 20Hz - 20KHz @ 100W
- PAD Attenuation: -20dB
- Output Impedance: 4ohm min.
- Phantom Power: +48Vcc
- Mains Voltage: AC 220-230 Vac / 50 Hz
- Dimensions (WxHxD): 440 x 255 x 240 mm - 17.32 x 10.04 x .45 in - Weight: 9.0 kg - 19.84 lbs.

CODE	MSRP EUR	MSRP GBP
L332L	€713,95	£655.41

CODE	MSRP EUR	MSRP GBP
D738D	€306,50	£281.37

POCKET-MIX - 4 channel mini mixer with power supplier

- 4 channel mini mixer with noiseless premps
- Ultra compact size 110 x 57x 31 mm
- Works with line or microphone inputs
- 4 mono inputs TRS 6,3mm
- Mono output TRS 6,3 mm
- 12V DC power supplier included



CODE	MSRP EUR	MSRP GBP
I516I	€42,97	£39.45

ADX-500 - Ultra low noise active DI Box

- Converts unbalanced input signal in balanced output signal
- Input jack 6,3mm unbalanced
- Output XLR F unbalanced
- Monitor out/link out 6,3mm
- Pad 0dB - 20 dB
- Output XLR M balanced
- Ground lift switch
- 9v battery operated
- Frequency response : 30Hz-20KHz
- Maximum input level: 0 ±20dB
- Noise level : = 105 dBu
- Power Requirement: AC 20~48V
- Battery : 9V blockcell 6LR91
- Dimension : 145X125X59mm - Weight : 700 g



CODE	MSRP EUR	MSRP GBP
D699D	€77,08	£70.76

ADX-800 LINK - Active 2-Channel DI-Box & Splitter

ADX-800 LINK is a DI-Box (Direct Injection Box) that converts up to two unbalanced audio signals (e.g. electric and / or acoustic guitars and basses, line signals such as guitar preamps, keyboards, multi-effects, computers, etc.) in balanced signals with XLR connections. This allows not only to attenuate the interferences that normally the unbalanced cables collect in the medium-long distances, but also acts as a splitter with a maximum of 3 outputs for Channel1 (2 XLR outputs + 1 balanced 1/4" TRS Jack). It can be powered either by the supplied power adapter, or through the +48V Phantom power coming from the mixer. It is equipped with a 3-position input attenuator (0dB, 20dB, 40dB) - to adapt the preamp stage to all types of signals - and the lift ground switch, very useful in case of ground loop. ADX-800 LINK is essentially an indispensable tool on stage, in the rehearsal room and recording studio to solve problems for musicians, DJs and sound engineers.

- 2 Channels DI-Box Operation
- 1 Channel Splitter function with max 3 Outputs
- TRS 1/4" Jack Outputs
- Balanced XLR Outputs
- 0/20/40dB Attenuation
- Operable via external Power Adapter (supplied) or external Phantom Power
- Ground Loop selector

- Frequency Response: 10Hz-30KHz ±1dB
- Max Input Level: 15 dBu ±1dB
- Noise Level: -65dBu
- Attenuation Pad: 0dB/-20dB/-40dB
- Modes: 2-Channel/Link
- Phantom Power (In case of power from balanced XLR connection): +48Vdc
- Power Adapter (included): 12Vdc/100mA min.
- Consumption: 2.3mA
- Unit Size: 112x65x36 mm - Unit Weight: 260g



CODE	MSRP EUR	MSRP GBP
J196J	€38,40	£35.25

PDX-100 - Passive DI-BOX

The DI-Box Soundsation PDX-100 converts high impedance audio signal from instruments or line outputs to a low impedance balanced output to be fed directly into a mixing console or amplifier input. Low impedance (Lo-Z) is capable of longer cable runs via XLR connection with lower signal degradation than high impedance.

- Jack input (6.3mm) unbalanced
- THRU connection (6.3mm jack) to send the audio signal to an additional high impedance input.
- High level input signals can be attenuated so as not to overload the inputs of a mixer or amplifier using the PAD selector (0dB, -20dB, -40dB).
- Inbuilt noise filter to help eliminate RF and mains hum
- GND selector with 3 positions to eliminate noise (GND, FLOAT, LIFT)

- Input: Unbalanced 6,3mm Jack
- Outputs: XLR Male balanced, 6,3mm THRU Jack unbalanced
- Input Impedance: > 100 KOhm
- Output Impedance: 600 Ohm
- Controls: PAD Selector (0/-20/-40dBu), GND Selector (GND, Float/Lift)
- Dimensions (WxDxH): 86 x 70 x 45 mm
- Weight: 0,234Kg



CODE	MSRP EUR	MSRP GBP
L847L	€18,15	£16.66

MIXER ACCESSORIES

LLMX-XLR - Mixing console LED lamp with XLR connector

- Easy and quick installation via XLR connection
- Powered by your mixer phantom power
- Easy to direct the light thanks to the flexible body
- LED lighting technology

- Length: 412 mm
- Power supply: DC 12V phantom power
- LED lamp technology



CODE	MSRP EUR	MSRP GBP
N756N	€27,27	£25.03

LLMX-BNC - Mixing console LED lamp with BNC connector

- Easy and quick installation via BNC connection
- Powered by your mixer BNC connector. No need to t
- Easy to direct the light thanks to the flexible body
- LED lighting technology

- Length: 415 mm
- Power supply: DC 12V BNC
- LED lamp technology



CODE	MSRP EUR	MSRP GBP
N757N	€27,27	£25.03

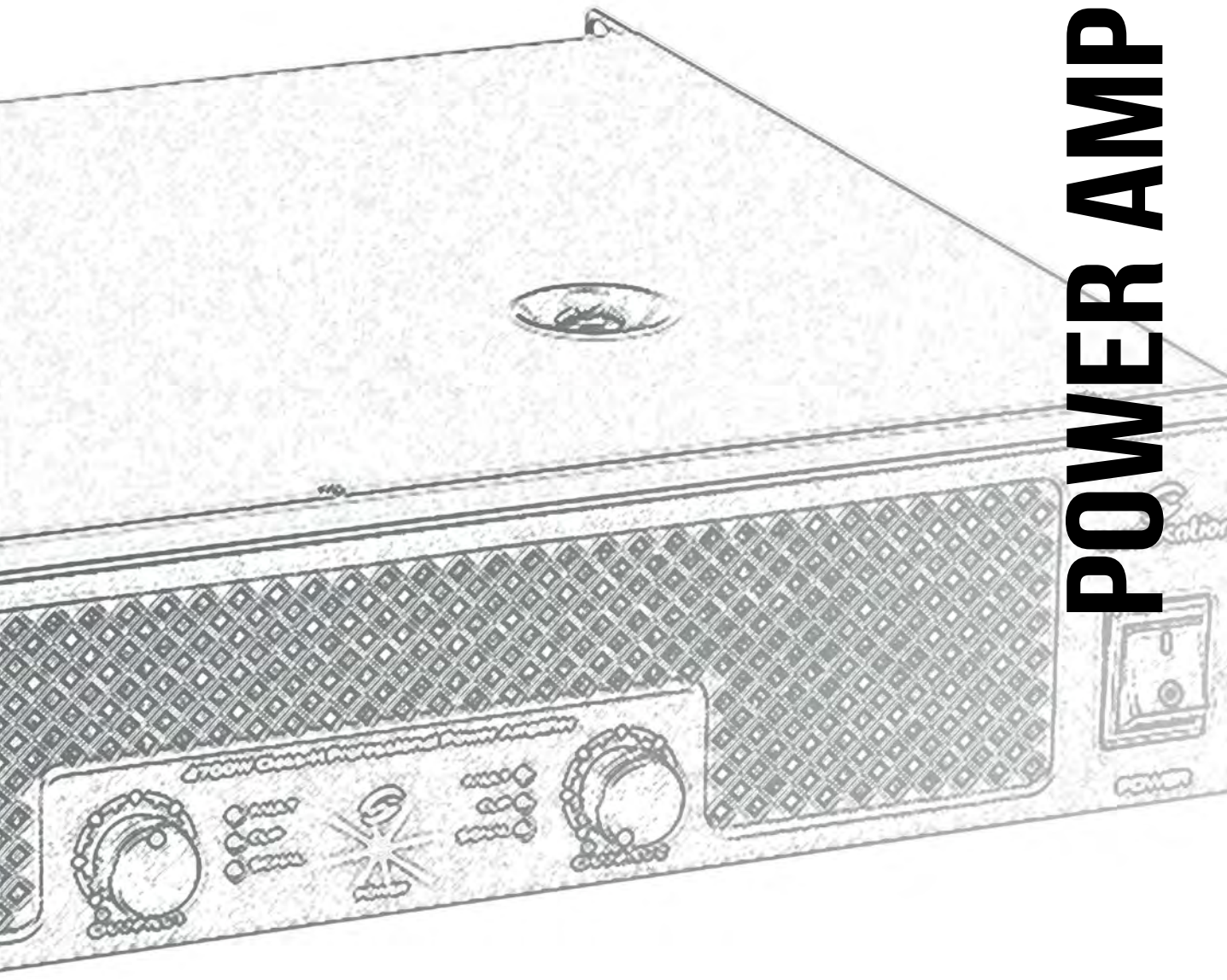

POWER AMPLIFIERS

ZEUS II Series

ZEUS II D-4700 - 2x1000W @ 8ohm, 2x1650W @ 4ohm Class-D 1U Professional Power Amplifier

ZEUS II D series is ideal for high-performance professional applications at high powers. It offers the most demanding users a very high dynamic response, a high damping factor and a very advanced protection system. It is designed with an excellent cooling system, with compact and stable mechanical capabilities, and can be used in live concerts, discos, night clubs, etc., thanks to its high reliability.

- 2 x 1000W @ 8ohm in just 7kg and 1U height standard rack
- Ultimate reliability through innovative cool-running high-density class-D technology with near-zero thermal buildup
- Ultra-efficient switch-mode power supply for noise-free audio, superior transient response and low power consumption
- Excellent designed flow-through air path and solid aluminum heat sinks can gain the maximum cooling
- Lightweight and rugged design, 1U height standard rack

- Stereo Output Power (RMS): 2x1000W @ 8ohm, 2x1650W @ 4ohm
- Bridged Output Power (RMS): 1x2850W @ 8ohm, 1x4700W @ 4ohm
- Input Sensitivity: 1.2V/32dB/26dB
- Input Impedance: > 10Kohm balanced or unbalanced
- Frequency response(1W, 8ohm): +0/-3dB 6.8Hz-34kHz
- 1KHz THD: 0.01—0.03%
- Damping Factor > 600
- Crosstalk > 70
- S/N Ratio > 104dB
- Amplifier Class: D
- Power Requirements 220V – 50/60Hz
- Input Connectors XLR
- Output Connectors Speakon®
- Cooling: 3 fans with airflow from front panel to the rear panel
- Variable wind speed, according to the temperature
- Dimension(WxHxD) 483 x 45 x 364.8 mm
- Height 1 Rack Unit
- Net Weight 7.2 Kg



CODE	MSRP EUR	MSRP GBP
E426E	€930,26	£853.98

ZEUS II D-5600 - 2x1200W @ 8ohm, 2x2000W @ 4ohm Class-D 1U Professional Power Amplifier

ZEUS II D series is ideal for high-performance professional applications at high powers. It offers the most demanding users a very high dynamic response, a high damping factor and a very advanced protection system. It is designed with an excellent cooling system, with compact and stable mechanical capabilities, and can be used in live concerts, discos, night clubs, etc., thanks to its high reliability.

- 2 x 1200W @ 8ohm in just 7kg and 1U height standard rack
- Ultimate reliability through innovative cool-running high-density class-D technology with near-zero thermal buildup
- Ultra-efficient switch-mode power supply for noise-free audio, superior transient response and low power consumption
- Excellent designed flow-through air path and solid aluminum heat sinks can gain the maximum cooling
- Lightweight and rugged design, 1U height standard rack

- Stereo Output Power (RMS): 2x1200W @ 8ohm, 2x2000W @ 4ohm
- Bridged Output Power (RMS): 1x3450W @ 8ohm, 1x5600W @ 4ohm
- Input Sensitivity: 1.2V/32dB/26dB
- Input Impedance: > 10Kohm balanced or unbalanced
- Frequency response(1W, 8ohm): +0/-3dB 6.8Hz-34kHz
- 1KHz THD: 0.01—0.03%
- Damping Factor > 600
- Crosstalk > 70
- S/N Ratio > 104dB
- Amplifier Class: D
- Power Requirements 220V – 50/60Hz
- Input Connectors XLR
- Output Connectors Speakon®
- Cooling: 3 fans with airflow from front panel to the rear panel
- Variable wind speed, according to the temperature
- Dimension(WxHxD) 483 x 45 x 364.8 mm
- Height 1 Rack Unit
- Net Weight 7.3 Kg



CODE	MSRP EUR	MSRP GBP
E427E	€962,34	£883.43

ZEUS II Series

ZEUS II D-3750 - 2x800W @ 8ohm, 2x1300W @ 4ohm Class-D 1U Professional Power Amplifier

ZEUS II D series is ideal for high-performance professional applications at high powers. It offers the most demanding users a very high dynamic response, a high damping factor and a very advanced protection system. It is designed with an excellent cooling system, with compact and stable mechanical capabilities, and can be used in live concerts, discos, night clubs, etc., thanks to its high reliability.

- 2 x 800W @ 8ohm in just 7kg and 1U height standard rack
- Ultimate reliability through innovative cool-running high-density class-D technology with near-zero thermal buildup
- Ultra-efficient switch-mode power supply for noise-free audio, superior transient response and low power consumption
- Excellent designed flow-through air path and solid aluminum heat sinks can gain the maximum cooling
- Lightweight and rugged design, 1U height standard rack

- Stereo Output Power (RMS): 2x800W @ 8ohm, 2x1300W @ 4ohm
- Bridged Output Power (RMS): 1x2300W @ 8ohm, 1x3750W @ 4ohm
- Input Sensitivity: 1.2V/32dB/26dB
- Input Impedance: > 10Kohm balanced or unbalanced
- Frequency response(1W, 8ohm): +0/-3dB 6.8Hz-34kHz
- 1KHz THD: 0.01—0.03%
- Damping Factor > 600
- Crosstalk > 70
- S/N Ratio > 104dB
- Amplifier Class: D
- Power Requirements 220V – 50/60Hz
- Input Connectors XLR
- Output Connectors Speakon®
- Cooling: 3 fans with airflow from front panel to the rear panel
- Variable wind speed, according to the temperature
- Dimension(WxHxD) 483 x 45 x 364.8 mm - Net Weight 7.1 Kg



CODE	MSRP EUR	MSRP GBP
E425E	€866,10	£795.08

ZEUS II H-2700 - 2 x 1000W @ 8ohm, 2 x 1350W @ 4ohm Professional Class-H Power Amplifier

ZEUS II Series represents a new era in affordable, quality power amplification. All five models (3 in AB-Class, and 2 in H-Class) in this series are powerful, rugged and reliable. They are suited for musicians, DJs, and entertainers as well as houses of worship, discos, clubs and pubs. Models are A-300, A-600, A-900 in AB-Class, and H-1800, H-2700 in H-Class. Features include RCA and XLR inputs, user selectable input sensitivity of 0.775V or 1.4V for the H-1800, H-2700 models, Speakon® and binding post outputs, stereo/parallel/bridge-mono modes, power/fault/signal presence/clip indicators, forced-air cooling.

- Intelligent Cooling System Makes Power Amplifier Work More Quiet
- Stereo/parallel/bridged-mono Modes
- High Quality Transformer with High Performance
- Upgraded Cooling Fans With Magnetic Suspension Technology And Low Noise
- 2U Chassis Design
- H-Class traditional and reliable circuitry with high-quality components
- Soft Start Function

- Stereo Nominal Output Power: 2 x 1000W @ 8ohm, 2 x 1350W @ 4ohm
- Bridged Nominal Output Power: 1 x 2700W @ 8 ohm
- Input Sensitivity: 1.4V / 0.775V
- Input Impedance: 20Kohm / 10Kohm
- Frequency Response: 20Hz / 20kHz
- Damping Factor: > 200
- S/N Ratio: > 100dB
- Amplifier: Class H
- Power Requirements: 220V – 50/60Hz
- Dimension(WxHxD): 482 x 370 x 88 mm
- Height 2 x 19" Rack Unit
- Net Weight: 19.5 kg



CODE	MSRP EUR	MSRP GBP
E539E	€590,57	£542.14

ZEUS II Series

ZEUS II H-1800 - 2 x 600W @ 8ohm, 2 x 900W @ 4ohm Professional Class-H Power Amplifier

ZEUS II Series represents a new era in affordable, quality power amplification. All five models (3 in AB-Class, and 2 in H-Class) in this series are powerful, rugged and reliable. They are suited for musicians, DJs, and entertainers as well as houses of worship, discos, clubs and pubs. Models are A-300, A-600, A-900 in AB-Class, and H-1800, H-2700 in H-Class. Features include RCA and XLR inputs, user selectable input sensitivity of 0.775V or 1.4V for the H-1800, H-2700 models, Speakon® and binding post outputs, stereo/parallel/bridge-mono modes, power/fault/signal presence/clip indicators, forced-air cooling.

- Intelligent Cooling System Makes Power Amplifier Work More Quiet
- Stereo/parallel/bridged-mono Modes
- High Quality Transformer with High Performance
- Upgraded Cooling Fans With Magnetic Suspension Technology And Low Noise
- 2U Chassis Design
- H-Class traditional and reliable circuitry with high-quality components
- Soft Start Function

- Stereo Nominal Rated Output Power: 2 x 600W @ 8ohm, 2 x 900W @ 4ohm
- Bridged Output Power: 1 x 1500W @ 8 ohm
- Input Sensitivity: 1,4V / 0,775V
- Input Impedance: 20Kohm / 10Kohm
- Frequency Response: 20Hz / 20kHz
- Damping Factor: > 200
- S/N Ratio: > 100dB
- Amplifier: Class H
- Power Requirements: 220V – 50/60Hz
- Dimension(WxHxD): 482 x 320 x 88 mm
- Height 2 x 19" Rack Unit
- Net Weight: 13.5 kg



CODE	MSRP EUR	MSRP GBP
E538E	€486,35	£446.47

ZEUS II A-900 - 2 x 300W @ 8ohm, 2 x 450W @ 4ohm Professional Class-AB Power Amplifier

ZEUS II Series represents a new era in affordable, quality power amplification. All five models (3 in AB-Class, and 2 in H-Class) in this series are powerful, rugged and reliable. They are suited for musicians, DJs, and entertainers as well as houses of worship, discos, clubs and pubs. Models are A-300, A-600, A-900 in AB-Class, and H-1800, H-2700 in H-Class. Features include RCA and XLR inputs, user selectable input sensitivity of 0.775V or 1.4V for the H-1800, H-2700 models, Speakon® and binding post outputs, stereo/parallel/bridge-mono modes, power/fault/signal presence/clip indicators, forced-air cooling.

- Intelligent Cooling System Makes Power Amplifier Work More Quiet
- Stereo/parallel/bridged-mono Modes
- High Quality Transformer with High Performance
- Upgraded Cooling Fans With Magnetic Suspension Technology And Low Noise
- 2U Chassis Design
- AB-Class traditional and reliable circuitry with high-quality components
- Soft Start Function

- Stereo Nominal Output Power: 2 x 300W @ 8 ohm, 2 x 450W @ 4 ohm
- Bridged Nominal Output Power: 1 x 900W @ 8 ohm
- Input Sensitivity: 1,4V / 0,775V
- Input Impedance: 20Kohm / 10Kohm
- Frequency Response: 20Hz / 20kHz
- Damping Factor: > 350
- S/N Ratio: > 95dB
- Amplifier: Class A/B
- Power Requirements: 220V – 50/60Hz
- Dimension(WxHxD): 482 x 320 x 88 mm
- Height 2 x 19" Rack Unit
- Net Weight: 11.5 kg



CODE	MSRP EUR	MSRP GBP
E537E	€310,65	£285.18

ZEUS II Series

ZEUS II A-600 - 2x200W @ 8ohm / 2x300W @ 4ohm Professional Class-AB Power Amplifier

ZEUS II Series represents a new era in affordable, quality power amplification. All five models (3 in AB-Class, and 2 in H-Class) in this series are powerful, rugged and reliable. They are suited for musicians, DJs, and entertainers as well as houses of worship, discos, clubs and pubs. Models are A-300, A-600, A-900 in AB-Class, and H-1800, H-2700 in H-Class. Features include RCA and XLR inputs, user selectable input sensitivity of 0.775V or 1.4V for the H-1800, H-2700 models, Speakon® and binding post outputs, stereo/parallel/bridge-mono modes, power/fault/signal presence/clip indicators, forced-air cooling.

- Intelligent Cooling System Makes Power Amplifier Work More Quiet
- Stereo/parallel/bridged-mono Modes
- High Quality Transformer with High Performance
- Upgraded Cooling Fans With Magnetic Suspension Technology And Low Noise
- 2U Chassis Design
- AB-Class traditional and reliable circuitry with high-quality components
- Soft Start Function

- Stereo Nominal Output Power: 2x200W @ 8ohm / 2x300W @ 4ohm
- Bridged Nominal Output Power: 1x600W @ 8ohm
- Input Sensitivity: 1,4V / 0,775V
- Input Impedance: 20Kohm / 10Kohm
- Frequency Response: 20Hz / 20kHz
- Damping Factor: > 350
- S/N Ratio: > 95dB
- Amplifier: Class A/B
- Power Requirements: 220V – 50/60Hz
- Dimension(WxHxD): 482 x 320 x 88 mm
- Height 2 x 19" Rack Unit
- Net Weight: 10.5 kg



CODE	MSRP EUR	MSRP GBP
E536E	€260,55	£239.18

ZEUS II A-300 - 2x100W @ 8ohm / 2x150W @ 4ohm Professional Class-AB Power Amplifier

ZEUS II Series represents a new era in affordable, quality power amplification. All five models (3 in AB-Class, and 2 in H-Class) in this series are powerful, rugged and reliable. They are suited for musicians, DJs, and entertainers as well as houses of worship, discos, clubs and pubs. Models are A-300, A-600, A-900 in AB-Class, and H-1800, H-2700 in H-Class. Features include RCA and XLR inputs, user selectable input sensitivity of 0.775V or 1.4V for the H-1800, H-2700 models, Speakon® and binding post outputs, stereo/parallel/bridge-mono modes, power/fault/signal presence/clip indicators, forced-air cooling.

- Intelligent Cooling System Makes Power Amplifier Work More Quiet
- Stereo/parallel/bridged-mono Modes
- High Quality Transformer with High Performance
- Upgraded Cooling Fans With Magnetic Suspension Technology And Low Noise
- 2U Chassis Design
- AB-Class traditional and reliable circuitry with high-quality components
- Soft Start Function

- Stereo Nominal Output Power: 2 x 100W @ 8ohm, 2 x 150W @ 4ohm
- Bridged Nominal Output Power: 1 x 300W @ 8ohm
- Input Sensitivity: 1,4V / 0,775V
- Input Impedance: 20Kohm / 10Kohm
- Frequency Response: 20Hz / 20kHz
- Damping Factor: > 350
- S/N Ratio: > 95dB
- Amplifier: Class A/B
- Power Requirements: 220V – 50/60Hz
- Dimension(WxHxD): 482 x 320 x 88 mm
- Height 2 x 19" Rack Unit
- Net Weight: 10 kg



CODE	MSRP EUR	MSRP GBP
E535E	€207,10	£190.12

ZEUS II Series

The new digital power amp range represents a big step-ahead in the SOUNDSATION Audio catalogue. thanks to S.P.S.M. technology it's possible to get amazing power while keeping the size and weight significantly reduced compared to conventional models in class A / B. The build quality and meticulous choice of components ensure best performance and extreme reliability even in the case of extraordinary stress.

D3600 - 3600 W Class D 2 Channels Power Amplifier



- 3600 W Max Power (bridge 8 Ohm)
- Forced Air Cooling with variable speed adjustment
- Balanced XLR
- 4-poles Speakon Outputs
- Protection: Thermal, Overload,DC output and Broken component
- LED indicators: Power, Error, Mute, Clip, Signal
- Configuration: Stero, Bridge

- Class D Switching Power Supply
- 2 Channels
- Power Out: 1 x 3600 W (bridge 8 ohm) - 2 x 1000 W (stereo 8 ohm) - 2 x 1700 W (stereo 4 ohm)
- Frequency Response: 20Hz-20KHz +/- 1dB
- Singla to noise Ratio (a-w-rms): >950dBA
- THD+N: <0,1% (1KHz)
- Balanced Input Impedance: 20KOhm
- Unbalanced Input Impedance: 10KOhm
- Damping Factor: >250 (5Hz-1KHz)
- Slew Rate: 20V/μs
- Cooling: forced cycle with adjustable speed Fan
- Power Supply: 90÷240 VAC 50/60Hz
- Power consumption: 1040W
- Dimension: 483 x 170 x 45 mm - 1U Rack - Weight: 2 Kg



CODE	MSRP EUR	MSRP GBP
N950N	€771,47	£708.21



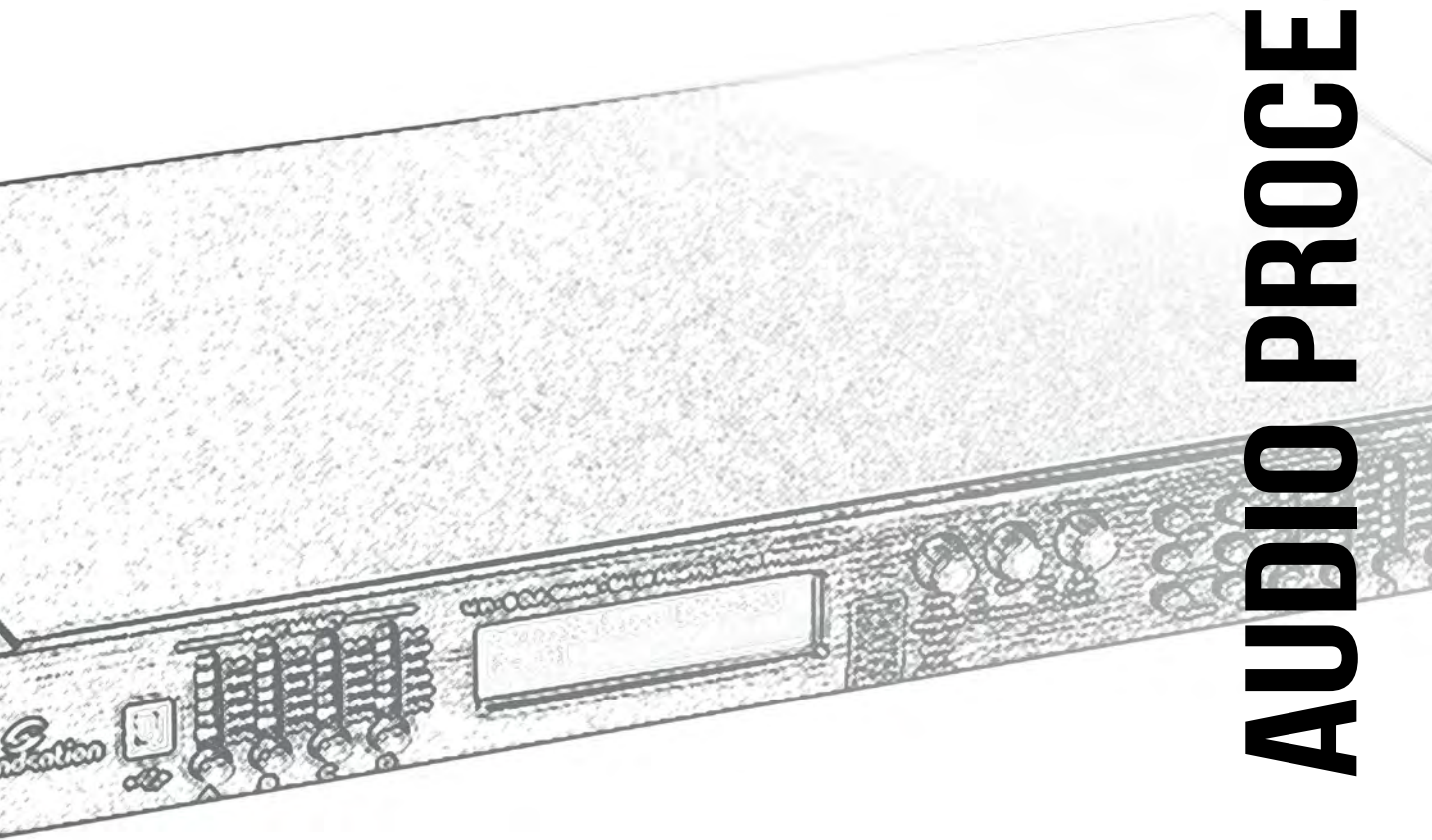

AUDIO PROCESSORS

The Digital Audio Processors of DCX NET series (DCX-240 NET, DCX-260 NET, DCX- 480 NET) are powerful DSP based audio processors, ideally suited for install applications, where they combine the functions of a multitude of conventional products in a compact 1U unit with extensive remote control capabilities and Ethernet functions. To achieve this, the units have up to four inputs and eight outputs which can be configured in a selection of basic crossover modes – 4 x 2 way; 2 x 3 way + 2 Aux; 2 x 4 way; and 1 x 8 way (as applicable to i/o configurations). They also offer a “free assign” mode, which allows completely flexible routing of any output from any combination of inputs. Each input has a gain control, variable delay, eight bands of fully parametric equalization. The parametric filter bands have a large selection of different filter types available, including shelving, notch, band-pass, phase and elliptical behaviors. Each output has a gain control, variable delay, high and low pass crossover filters, 8 bands of fully parametric equalization, polarity switching and, additionally, a fully featured limiter, and a final clip limiter. The crossover filters offer slopes of up to 48dB/Octave, with a variety of responses available. Remote control is catered for in the form of Ethernet by TCP/IP and RS485 ports, and multiple user memories are provided for the storage and recall of settings.

DCX-480 NET - Professional digital audio processor

- 4 Signal Inputs and 8 Signal Outputs (XLR Balanced)
- Network Control Via USB Or TCP/IP LAN (Ethernet)
- 20 Presets Memory in the hardware unit
- Butterworth, Bessel, Linkwitz-Riley Filters
- 20 x 2 Characters Blue LCD Display
- 8 Bands Fully Parametric (Frequency, Q And Gain) Equalizer
- Limiter available on each Output Channel for added safety of the speakers
- USB Interface dedicated to PC control
- RS-485 Interface
- DSP can search the IP address automatically
- One PC can manage many different DSP processors
- Data from DSPs exchange or share freely
- IP address obtain Automatically
- PORT access Automatically
- IP address can be set by users



- Power Supply: 80-240Vac - 50/60Hz
- DSP 64: bit floating
- Sampling rate: 96KHz
- Dynamic range: > 110dB
- Maximum Input Level: +23dBu
- Maximum Output: Level +23dBu
- Operational Frequency Range: 20Hz ÷ 20KHz
- Input processing latency: 1000ms
- Output processing latency: 1000ms
- Memory Presets: 20
- Limiters: -20dB ÷ +20dB
- Phase Inverter (Polarity): 180°

- dB/Octave Range: 12, 18, 24, 48
- Equalizer: 8 band fully parametric for each Input/Output Channel
- Filters: Butterworth, Bessel, Linkwitz-Riley
- Display LCD (2 Row x 20 Characters)
- Inputs: 4
- Outputs: 8
- Network Control: Via USB Or TCP/IP LAN (Ethernet)
- USB Interface: YES (for PC control)
- RS-485 Interface: YES
- Dimension (WxHxD): 483x50x290mm - Weight: 3,25Kg

CODE	MSRP EUR	MSRP GBP
E567E	€835,08	£766.60

DCX-260 NET - Professional digital audio processor

- 2 Signal Inputs and 6 Signal Outputs (XLR Balanced)
- Network Control Via USB Or TCP/IP LAN (Ethernet)
- 20 Presets Memory in the hardware unit
- Butterworth, Bessel, Linkwitz-Riley Filters
- 20 x 2 Characters Blue LCD Display
- 8 Bands Fully Parametric (Frequency, Q And Gain) Equalizer
- Limiter available on each Output Channel for added safety of the speakers
- USB Interface dedicated to PC control
- RS-485 Interface
- DSP can search the IP address automatically
- One PC can manage many different DSP processors
- Data from DSPs exchange or share freely
- IP address obtain Automatically
- PORT access Automatically
- IP address can be set by users



- Power Supply: 80-240Vac - 50/60Hz
- DSP 64: bit floating
- Sampling rate: 96KHz
- Dynamic range: > 110dB
- Maximum Input Level: +23dBu
- Maximum Output: Level +23dBu
- Operational Frequency Range: 20Hz ÷ 20KHz
- Input processing latency: 1000ms
- Output processing latency: 1000ms
- Memory Presets: 20
- Limiters: -20dB ÷ +20dB

- Phase Inverter (Polarity): 180°
- dB/Octave Range: 12, 18, 24, 48
- Equalizer: 8 band fully parametric for each Input/Output Channel
- Filters: Butterworth, Bessel, Linkwitz-Riley
- Display LCD (2 Row x 20 Characters)
- Inputs: 2
- Outputs: 6
- Network Control: Via USB Or TCP/IP LAN (Ethernet)
- USB Interface: YES (for PC control)
- RS-485 Interface: YES
- Dimension (WxHxD): 483x50x290mm - Weight: 3,25Kg

CODE	MSRP EUR	MSRP GBP
E541E	€701,47	£643.95

DCX-240 NET - Professional digital audio processor

- 2 Signal Inputs and 4 Signal Outputs (XLR Balanced)
- Network Control Via USB Or TCP/IP LAN (Ethernet)
- 20 Presets Memory in the hardware unit
- Butterworth, Bessel, Linkwitz-Riley Filters
- 20 x 2 Characters Blue LCD Display
- 8 Bands Fully Parametric (Frequency, Q And Gain) Equalizer
- Limiter available on each Output Channel for added safety of the speakers
- USB Interface dedicated to PC control
- RS-485 Interface
- DSP can search the IP address automatically
- One PC can manage many different DSP processors
- Data from DSPs exchange or share freely
- IP address obtain Automatically
- PORT access Automatically
- IP address can be set by users



- Power Supply: 80-240Vac - 50/60Hz
- DSP 64: bit floating
- Sampling rate: 96KHz
- Dynamic range: > 110dB
- Maximum Input Level: +23dBu
- Maximum Output: Level +23dBu
- Operational Frequency Range: 20Hz ÷ 20KHz
- Input processing latency: 1000ms
- Output processing latency: 1000ms
- Memory Presets: 20
- Limiters: -20dB ÷ +20dB
- Phase Inverter (Polarity): 180°

- dB/Octave Range: 12, 18, 24, 48
- Equalizer: 8 band fully parametric for each Input/Output Channel
- Filters: Butterworth, Bessel, Linkwitz-Riley
- Display LCD (2 Row x 20 Characters)
- Inputs: 2
- Outputs: 4
- Network Control: Via USB Or TCP/IP LAN (Ethernet)
- USB Interface: YES (for PC control)
- RS-485 Interface: YES
- Dimension (WxHxD): 483x50x290mm - Weight: 3,25Kg

CODE	MSRP EUR	MSRP GBP
E540E	€627,98	£576.49

DIGITAL series

DFX2448 - 24 bit Multieffect Processor 1U Rack

The DFX-2448 is a digital effects processor packaged within a 19 inch rackmount 1U housing. The user interface has been carefully designed to be user friendly and consists of a central rotary encoder for navigation purposes, a potentiometer for parameter settings, with three further potentiometers to control INPUT, OUTPUT and MIX levels. The DFX-2448 has a 2 x 20 LCD alphanumeric display for easy access and set up, as well as LED indication on CLIP, MUTE and a TAP time LED. The unit can be connected via MIDI as well as USB for external control and two way movements of data. There are also rear jack connections for foot pedal control of effects BYPASS and the setting of TAP DELAY externally. TAP DELAY can also be varied by a front panel switch. The 16 preset can be modified directly via the Unit Panel or via the supplied PC Software Manager.



- 24 bit Processor with 24 bit DELTA-SIGMA converters
- Built-in Effects : REVERB, DELAY, CHORUS, ROTARY, PITCH SHIFTER and combined FX (CHR/FLG+REVERB, DELAY+REVERB, CHR/FLG+DELAY)
- Advanced MIX system: (INPUT-OUTPUT-MIX)
- Wide LCD screen for an optimal check of the status of the unit
- Ultra-rugged construction allowing to use the unit in Live performances
- Software manager for remote unit controlling included

- 24 Bit Processing:
- Converters: 24-Bit Delta-Sigma, 128-times oversampling
- Sampling Rate: 48 KHz
- Inputs: Balanced XLR & JACK TRS
- Input Max Level: +15 dBu
- Input impedance: approx. 30 KOhm
- Outputs: Balanced XLR & JACK TRS
- Output Max Level: +21 dBu
- Output Impedance: approx. 150 Ohm
- Foot Switch Input: TS Jack
- MIDI connection: 2 x DIN 5 pin
- USB connection: USB Connector type "A"
- Frequency Response: 10 Hz to 22 kHz, -3 dB
- Dynamic range: 103 dB, 10 Hz to 22 kHz A-Weighted
- THD: 0.01 % typ. @ 0 dBFS
- Crosstalk: -75 dB @ 1 kHz
- Signal-to-noise Ratio: 10 Hz to 22 kHz >100 dB @ 0 dBu, A-weighted
- Power consumption: approx. 15 W



DFE1224 - Digital Feedback Eliminator

The DFE-1224 is a feedback detection device that can be used in dual channel or mono mode. The feedback system analyzes all frequencies in the signal path, determines the cause of the Larsen effect and cancels it by implementing the 12 real-time high precision notch filters that have -45dB attenuation. The system is adjustable in 15 steps, allowing the user to change the DFE-1224 sensitivity to audio feedback according to your situation requirements. The parameter settings of the 12 notch filters per channel remain in RAM memory, but if it is required to keep them as a setting for future reference they must be saved in a user memory preset. If you switch off the DFE-1224 before saving any changed settings to a memory, these will be lost and on power up the unit will default to the last saved memory settings. The unit has 20 memories available, with 4 factory presets and 16 user memory presets. The DFE-1224 has a bypass system that has been designed within the analog domain and the unit can be connected via MIDI as well as USB for external control and two way movements of data.



- 24 bit Audio Processor with 12 Real-time Notch filters
- Professional 24 bit AD/DA Converters
- Adjustable parameter for each effect and MIX between input and output signal
- User-friendly panel interface thanks to the rotative knob "Navigation" that allows to get all the parameter
- Wide LCD screen for an optimal check of the status of the unit
- Ultra-rugged construction allowing to use the unit in Live performances
- Software manager for remote unit controlling included

- 24 bit Audio Processor for filters and professional AD/DA converters
- Inputs: Balanced XLR-F & Jack
- Outputs: Balanced XLR-M & Jack
- Converters: AD/DA 24 bit
- User Memories: 16
- Recall Memories: 20
- S/N Ratio: > 90 dBA
- THD+N: < 0.01% @ -6 dBFS
- Input Max Level: 9 dBu
- Output Max Level: 9 dBu
- Frequency Response: 20Hz - 20kHz +/- 0.5dB
- LCD Display: Graphic 2x20 characters
- Additional outputs: USB, MIDI
- Dimension: 1U Rack - Weight : 3 Kg

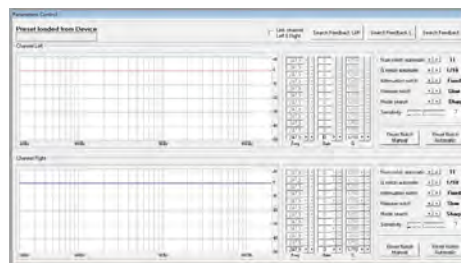

CODE	MSRP EUR	MSRP GBP
N843N	€215,48	£197.81

CODE	MSRP EUR	MSRP GBP
N844N	€210,69	£193.41

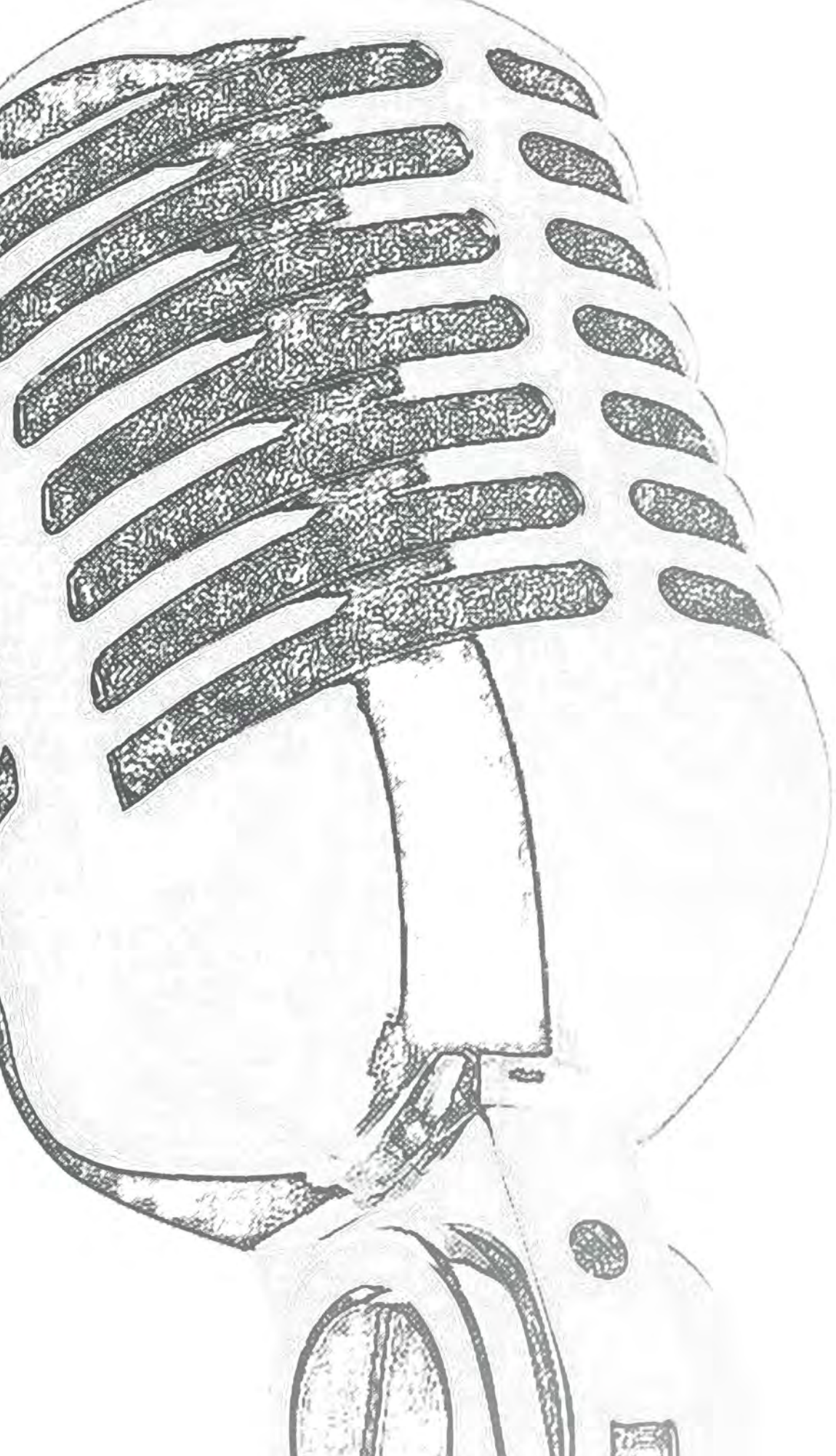

MICROPHONES

DM99 - Pro Dynamic Vocal Microphone

SOUNDSATION microphones line is inspired to the needs of musicians and music lovers. Sound excellence, comfort, design and product innovation come first. DM99 is the SOUNDSATION flagship in dynamic technology based vocal microphones. It is a cardioid dynamic mic. Designed for best performance of skilled singers. Rugged construction, warm and clear vocal reproduction will donate the user a unique experience in every live event small clubs or large venues.

- Dynamic vocal microphone with smooth mid-frequency presence rise for excellent voice projection
- Cardioid polar pattern minimizes ambient noise and feedback
- Ultra-wide frequency response for crystal and clear sound
- Extremely high signal output lets your voice cut through
- Clear and bright vocal reproduction
- High-quality components and rugged construction
- Microphone stand adapter for easy stand placement
- Comes with 3 mt XLR M - XLR F professional cable
- Comes with carrying bag

- Transducer principle: Dynamic
- Polar Pattern : Cardioid
- Frequency Response: 50Hz-16kHz
- Sensitivity -55dB±3dB(0dB=1V/Pa at 1kHz)
- Output Impedance: 400 Ohm ±30%
- Net weight: gr 320

CODE	MSRP EUR	MSRP GBP
M274M	€64,22	£58.95



VOCAL Series

VOCAL 300 PRO - Professional Cardioid Dynamic Microphone

SOUNDSATION VOCAL series of microphones is the perfect answer to all those users who require rugged and reliable tools, able to improve the range of frequencies typical of male and female voices, and wink at its own wallet. The VOCAL 300 PRO is a professional dynamic microphone with cardioid polar pattern, high sensitivity, wide frequency response, and high sound pressure capability. It belongs to VOCAL series, but it actually is a great microphone for vocal and instrument miking, both in live and studio application.

- Dynamic vocal microphone with smooth mid-frequency presence rise for excellent voice reproduction
- Wide frequency response for crystal yet clear sound
- High signal output, lets your voice cut through
- Cardioid polar pattern minimizes ambient noise and feedback
- On/off switch
- 5m XLR Female - XLR Male cable included
- High-quality components and exceptionally rugged construction

- Type: Dynamic
- Directivity: Cardioid
- Polar Pattern: Uni-Directional
- Frequency Response: 68Hz - 17.2kHz (±3dB)
- Sensitivity: -60dB ±3dB (0dB=1V/Pa @ 1kHz)
- Output impedance: 300ohms, ±15%
- Microphone Size (HxDiameter): 29,5 x D50,5 max. x D22,5 min. cm
- Carton Size (LxHxD): 23,3 x 6,7 x 14 cm
- Microphone Weight: 0,29kg
- Carton Weight: 0,725kg



CODE	MSRP EUR	MSRP GBP
L805L	€18,27	£16.77



VOCAL 100 - Cardioid Dynamic Microphone

SOUNDSATION VOCAL series of microphones is the perfect answer to all those users who require rugged and reliable tools, able to improve the range of frequencies typical of male and female voices, and wink at its own wallet. The VOCAL 100 is a dynamic microphone with cardioid polar pattern whose sensitivity and frequency response will impress when compared to other models of same price range. Although it's been designed for live vocal use, the VOCAL 100 is a great transducer even for acoustic instruments and percussions.

- Specifically designed for Singers
- Ready for KARAOKE applications
- Rugged construction
- On/off switch
- Cardioid polar pattern minimizes ambient noise and feedback
- Quality components
- 5m XLR Female - 6.3mm (1.4") TS jack cable included

- Type: Dynamic
- Directivity: Cardioid
- Polar Pattern: Uni-Directional
- Frequency Response: 70Hz - 16kHz (±3dB)
- Sensitivity: -57dB ±3dB (0dB=1V/Pa @ 1kHz)
- Output impedance: 300ohms, ±15%
- Microphone Size (HxD):
- Carton Box Size (LxHxD): 23,7 x 6,5 x 10,5 cm
- Microphone Weight: 0,152kg
- Carton Box Weight: 0,43kg



CODE	MSRP EUR	MSRP GBP
L804L	€10,61	£9.74



WF-U99 INEAR - UHF 99-Channel Stereo In-Ear Monitor System

WF-U99 INEAR monitoring system is for all those professionals who need maximum mobility on stage without losing a reliable stereo monitoring system and high-quality audio. Rugged, reliable, easy to transport and install, the WF-U99 INEAR features independent Stereo/Mono modulation functions, PLL technology, and 99 channels. The pocket receiver is equipped with illuminated LCD and is absolutely easy to set up. It is supplied with earphones that provide an optimal reproduction of the entire audio spectrum. In the package, you can also find various ear-fitting pads for an individual fit. The half-rack receiver unit is provided with a 19" standard rack mount kit. All connections are balanced and assure maximum audio standards.

- UHF Phase Lock circuit, stable and low harmonic radiation
- 99-Channels in 10 Groups with frequencies arranged in order to avoid interferences
- 823-832MHz + ISM Europe (863-865MHz) Carrier Wave Frequency Range
- User-friendly interface with a wide illuminated LCD Display
- Independent Mono/Stereo Modulation Function between Transmitter and Receiver
- Excellent circuit design to achieve the best signal/noise ratio
- Supplied with High-Dynamics Earphones in soft Case
- Compact and robust Receiver Configuration Design
- 19" Standard Rack Mount Transmitter with Mounting Kit
- Balanced/Unbalanced Inputs with Combo Connectors

- Carrier Frequency: UHF 823-832 + 863-865 MHz
- Modulation: FM Stereo
- Output Power: 10mW
- Effective Working Distance: 80 meters (without obstacles)
- Oscillation Mode: PLL phase-locked frequency synthesizer
- Maximum Deviation: ±68KHz
- Comprehensive S/N ratio: > 105dB
- Comprehensive T.H.D: <0.4% @1 KHz
- Audio Input: 2x Line-Inputs with Combo Connectors (XLR and jack 6.3mm)
- Transmitter Audio Output: 6.3mm Stereo Jack (Headphones)
- Transmitter Size (WxHxD): 210 x 43 x 182 mm
- Transmitter Weight: 1.06 kg
- Frequency Response: 40Hz-16KHz±3dB
- Stereo Separation: =45dB @1 KHz
- Receiver Output socket: 3.5mm stereo headphone jack
- Receiver Output Power: 2x150mW (THD3%)
- Battery: 2x AA-Type Batteries
- Receiver Current consumption: 185mA (typical)
- Battery Current/life: About 7 hours
- Receiver Size (WxHxD): 66 x 111 x 26 mm (antenna excluded)
- Receiver Antenna Size (W/DxH): Ø4 x 105 mm
- Receiver Weight: 143 g (batteries included)



CODE	MSRP EUR	MSRP GBP
R220R	€310,65	£285.18

WF-U99 RX - Additional Receiver and stereo earphone set for WF-U99 INEAR In-Ear Monitor System

WF-U99 RX is a kit for SOUNDSTATION WF-U99 INEAR systems that provides additional receivers and earphones to bands or groups of people who share same audio contents on the stage or in other monitoring applications. Rugged, reliable, easy setup, the WF-U99 RX features independent Stereo/Mono audio monitoring, PLL technology, and 99 channels. It is equipped with illuminated LCD and is absolutely easy to set up. It is even supplied with earphones that provide an optimal reproduction of the entire audio spectrum. In the package, you can also find various ear-fitting pads for an individual fit.

- Receiver Size (HxWxD): 111 x 66 x 26 mm (antenna excluded)
- Receiver Antenna Size (W/DxH): Ø4 x 105 mm
- Receiver Weight: 143 g (batteries included)

CODE	MSRP EUR	MSRP GBP
R221R	€167,02	£153.32



WF-U2600 SYSTEM - Dual UHF True Diversity Multi-Channel Wireless Microphone System

WF-U2600 is a dual UHF True Diversity professional wireless microphone with 240 channels for each microphone, and a simple and intuitive user interface. "True Diversity" means that the receiving system is equipped with two antennas, two receiving circuits and a device capable of continuously choose the stronger and interference-free signal. The WF-U2600 is built with leading technology that allows the integration of many of the major functions - such as amplification section, digital signal processing, PLL (Phase-Locked Loop) frequency synthesis, and more - into a few CHIPS. This allows us to offer highly professional performance yet cost-effective products. The WF-U2600 is also equipped with the automatic frequency search system and IR sync system for channel synchronization between receiver and transmitter in a quick way. Furthermore, the Digital Pilot Technology not only allows to monitor reception level and battery charge, but even to operate up to 200 sets multiple systems without problems. Finally, the receiver comes with a kit for mounting in 1 standard 19" rack unit. The kit is composed by two L-shape adapters and four screws to mount them on both receiver sides. WF-U2600HH system is composed by two Hand Transmitter with Professional Dynamic Cardioid Capsule and one Dual UHF True Diversity Receiver.

Common Features

- UHF True Diversity Technology to Avert Interferences
- 240 Preset Channels for each microphone
- IR Matching System for Quick Setup
- 630-660MHz UHF Band
- Simple and Outright User Interface
- LCD display on Transmitters and TFT color displays on Receiver
- Digital Pilot Technology to allow up to 200 systems operation simultaneously without interferences
- Transmitter AF-level and Battery-Low Monitoring directly on the Receiver
- Automatic mute function on microphones
- 80m Ideal Distance (without obstacles)
- Professional Hand held Microphone with Dynamic Cardioid Capsule
- 19" Rack-Mount adapter kit included

Common Specs

- Carrier Frequency: UHF630-660MHz
- Frequency Stabilization: < ±30ppm
- Dynamic Range: > 100dB
- Total Harmonic Distortion: <0.5%
- Frequency Response: 40Hz-15KHz ±3dB
- Audio Output Level: Balanced 400mV; Unbalanced 400mV
- Receiver Power Supply: DC 13.5V / 1.5A
- Receiver Power Consumption: 5W
- Signal/Noise Ratio: > 95dB
- Receiving Sensitivity: 5dBuV
- De-Emphasis: 50uS
- Receiver Size (WxHxD): 420 x 50 x 220 mm (antennas not incl.)
- Antenna: 255 mm (not bent)
- Receiver Net Weight: 2.02 kg
- Transmitter Power: 10mW(Max)
- Modulation Type: FM
- Max Deviation: ±25KHz
- Transmitter Battery Voltage: 3V (2x1.5V AA Battery)
- Continuous Using: 5 hours
- Hand-held Mic. Size (W/DxH): Ø35 (min) - Ø53 (max) x 260 mm
- Hand-held Mic. Net Weight: 0.335 kg (batteries included)

Other Specs for WF-U2600HP

- Body-pack with Connector Locking System
- Professional and Lightweight Headset with High-Sensibility Condenser Cardioid Capsule
- Pocket Transmitter Size (W/DxH): 62 x 103 x 30 mm
- Pocket Transmitter Net Weight: 0.132 kg (batteries included)

CODE	MODEL	MSRP EUR	MSRP GBP
E073E	WF-U2600HH	€466,73	£428.46
E074E	WF-U2600HP	€469,84	£431.31



WF-U2300 SYSTEM- UHF True Diversity Dual Wireless Microphone System



WF-U2300 is a dual UHF True Diversity professional wireless microphone with 300 channels for each microphone, and a simple and intuitive user interface. "True Diversity" means that the receiving system is equipped with two antennas, two receiving circuits and a device capable of continuously choose the stronger and interference-free signal. This technology is used for both single systems (WF-U1300) or dual systems (WF-U2300). The WF-U2300 is built with leading technology that allows the integration of many of the major functions - such as amplification section, digital signal processing, PLL (Phase-Locked Loop) frequency synthesis, and more - into a single CHIP. This allows us to offer highly professional performance yet cost-effective products. The WF-U2300 is also equipped with the automatic frequency search system and IR sync system for channel synchronization between receiver and transmitter in a quick way. Furthermore, the Digital Pilot Technology not only allows to monitor reception level and battery charge, but even to operate with multiple systems without problems. Finally, there are two optional kit for rack mounting of 1 or 2 receivers, respectively, on 1 or 2 standard 19" rack units.

Common Features

- UHF True Diversity Technology to Avert Interferences
- 300 Preset Frequencies for each microphone, and IR Matching System for Quick Setup
- 823-832 MHz UHF Band
- Simple and Outright User Interface with LCD display on Transmitter and Receiver
- Digital Pilot Technology to allow multi system Operation
- Transmitter AF-level and Battery-Low Monitoring directly on the Receiver
- 80 m Ideal Distance (without obstacles)
- Bodypack Transmitters with Connector Locking System
- Professional and Lightweight Headsets with High-Sensitivity Condenser Cardioid Capsules
- Rack-Mount Kit for 1 or 2 receiver units to 1x or 2x 19" rack unit (optional)



Common Specs

- Carrier Frequency: UHF823-832 MHz
- Frequency Stabilization: < ±30ppm
- Dynamic Range: >90 dB
- Total Harmonic Distortion: <0.5%
- Frequency Response: 40 Hz-15kHz ±3 dB
- Audio Output Level: Balanced 400 mV; Unbalanced 400 mV
- Packing Dimensions (WxHxD): 435x104x321 mm
- Packing Gross Weight: 2.5 kg
- Receiver Power Supply: DC 12V/500 mA
- Receiver Consume Power: 7 W
- Signal/Noise Ratio: >90 dB
- Receiving Sensitivity: 5 dBuV
- De-Emphasis: 75 uS
- Dimensions (WxHxD): 210x43x187 mm (antennas not incl.)
- Antenna: 255 mm (not bent)
- Net Weight: 0.53 kg
- Transmitter Power: 10 mW(Max)
- Modulation Type: FM
- Max Deviation: ±25 kHz
- Battery Voltage: 3 V (2x1.5 V AA Battery)

Other Specs for WF-U2300HP

- Body-pack with Connector Locking System
- Professional and Lightweight Headset with High-Sensitivity Condenser Cardioid Capsule
- Pocket Transmitter Dimensions (WxHxD): 62x103x30 mm
- Antenna (W/DxH): Ø3x9 mm
- Pocket Transmitter Net Weight: 0.132 kg (batteries included)
- Hand-held Mic. Dimensions (W/DxH): Ø35(min)-Ø53(max)x260 mm
- Hand-held Mic. Net Weight: 0.335 ka (batteries included)



CODE	MODEL	FREQUENCY	MSRP EUR	MSRP GBP
E560E	WF-U2300PP	2 bodypack + lavalier	€256,72	£235.67
E075E	WF-U2300HH	2 hand-held mics	€250,50	£229.96
E076E	WF-U2300HP	1 hand-hel mic+1 bodypack	€252,04	£231.37



WF-U1300 SYSTEM



WF-U1300 is a UHF True Diversity professional wireless microphone with 300 channels and a simple and intuitive user interface. "True Diveristy" means that the receiving system is equipped with two antennas, two receive circuits and a device capable of continuously choose the stronger and interference-free signal. This system is built with leading technology that allows the integration of many of the major functions - such as amplification section, digital signal processing, PLL (Phase-Locked Loop) frequency synthesis, and more - into a single CHIP. This allows us to offer highly professional performance yet cost-effective products. The WF-U1300 is also equipped with the automatic frequency search system and IR sync. system for channel synchronization between receiver and transmitter in a quick way. Furthermore, Digital Pilot Technology not only allows to monitor reception level and batteries charge, but even to operate with multiple systems without problems. Finally, there are two optional kit for rack mounting of 1 or 2 receivers, respectively, on 1 or 2 standard 19" rack units.

- UHF True Diversity Technology to Avert Interferences
- 300 Preset Frequencies and IR Matching System for Quick Setup
- 823-832MHz UHF Band
- Simple and Outright User Interface with LCD display on Transmitter and Receiver
- Digital Pilot Technology to allow Multi-system Operation
- Transmitter AF-level and Battery-Low Monitoring directly on the Receiver
- 80m Ideal Distance (without obstacles)
- Rack-Mount Kit for 1 or 2 receiver units to 1x or 2x 19" rack unit (optional)

SYSTEM

- Carrier Frequency: UHF823-832MHz
- Frequency Stabilization: < ±30ppm
- Dynamic Range: >90dB
- Total Harmonic Distortion: <0.5%
- Frequency Response: 40Hz-15KHz ±3dB
- Audio Output Level: Balanced 400mV; Unbalanced 400mV

RECEIVER

- Power Supply: DC 17V / 300mA
- Consume Power: 5W
- Signal/Noise Ratio: >90dB
- Receiving Sensitivity: 5dBuV
- De-Emphasis: 75uS
- Dimensions (WxHxD): 210 x 43 x 187 mm (antennas not included)
- Antenna: 255 mm (not bent)
- Net Weight: 0.53 kg

HANDHELD TRANSMITTERS

- Transmitter Power: 10mW (Max)
- Modulation Type: FM
- Max Deviation: ±25KHz
- Spurious Emission: >40dB
- Battery Voltage: 3V (2x1.5V AA Batteries)
- Continuous Using: 5 hours



WF-U1300H True Diversity 300 Channels Wireless Microphone System with Handheld Microphone

- Professional Handheld Microphone with Dynamic Cardioid Capsule
- Dimensions (W/DxH): Ø35 (min) - Ø53 (max) x 260 mm
- Net Weight: 0.335 kg (batteries included)

CODE	MSRP EUR	MSRP GBP
I374I	€213,32	£195.83

WF-U1300P True Diversity 300-CH Wireless Microphone System with pocket transmitter and Headset

- Bodypack with Connector Locking System
- Professional and Lightweight Headset with High-Sensitivity Dynamic Cardioid Capsule
- Dimensions (WxHxD): 62 x 103 x 30 mm
- Antenna (W/DxH): Ø3 x 9 mm
- Net Weight: 0.132 kg (batteries included)

CODE	MSRP EUR	MSRP GBP
I624I	€214,92	£197.30



WF-D190H MKII - 90-channel UHF Digital Wireless Hand-held Microphone System

WF-D190 MKII adopts a brand-new digital transmission technology and hardware encryption of audio data that enable superior audio quality compared to analog UHF systems, very-low latency (better than 2.4GHz systems) and maximum security due to the cryptographic hardware. The unique 16bit digital ID pilot technology avoids interferences even on same frequency, and allows continuous exchange of data between transmitter and receiver, such as battery level, transmission power, squelch operation, etc. The system is also equipped with automatic frequency scanning and frequency spectrum display, which allow the user to select the less disturbed frequencies in every environment it operates. It features 90 frequencies, divided into 15 groups, each of which contains 6 channels. The user interface is very simple and intuitive, thanks to the TFT color display on the receiver and the simplicity of its setup menus. The handheld transmitter and the bodypack, however, are equipped with LCD display with auto-off function, to save battery consumption. The handheld microphone is also equipped with rechargeable lithium battery that can be recharged via the USB port on the back of the receiver. Finally, two 19" rack mount kit are available to install 1 or 2 receivers, respectively, in 1 or 2 rack units.

- UHF E-Band operation (823-832 MHz)
- Digital audio transmission technology
- Unique digital 16-bit ID pilot technology
- Transmitter AF-level, Audio-level and Battery-Low monitoring on the Receiver
- Double antenna diversity technology
- No crosstalk disturbance even on same frequency
- Ultra-short audio latency
- 48kHz sampling frequency
- 30-20kHz frequency response
- Colorful TFT display and menu settings on receiver
- Auto frequency scanning and spectrum display
- 50m Ideal Distance (without obstacles)
- Infrared Tx-Rx synchronization system for quick system setting
- Professional Handheld Microphone with Professional Dynamic Cardioid Capsule and rechargeable Lithium Battery
- Rack-Mount Kit for 1 or 2 receiver units to 1x or 2x 19" rack unit (optional)

- System Carrier Frequency: UHF823-832MHz
- System Bandwidth: 9MHz
- System Channel Bandwidth: 100kHz
- Preset Group/Channel: 10 groups, 9 frequencies in each group
- Dynamic Range: >98dB
- Total Harmonic Distortion: <0.1%
- Frequency Response: 30Hz-20kHz / ±2dB
- Audio Output Level: Balanced 400mV; Unbalanced 400mV
- System Packing Dimensions (WxHxD): 436 x 104 x 324 mm
- System Packing Gross Weight: 2.5 kg
- Power Supply: DC 12V / 1000mA
- Receiver Consume Power: 5W
- Receiver Signal/Noise Ratio: >98dB
- Receiving Sensitivity: -95dBm
- Transmission Delay: <3ms
- Receiver Dimensions (WxHxD): 210 x 45 x 118 mm (antennas not incl.)
- Receiver Antenna: 255 mm (not bent) with BNC connector
- Receiver Net Weight: 0.4 kg
- Transmitter Power: 10mW (Max)
- Battery Voltage Handheld Transmitter: 1x 3.7V - 1200mAh Lithium Rechargeable Battery (type 18500)
- Modulation Type: DQPSK
- Transmitter Continuous Using: 5 hours (HI Trans. power); 7 hours (LO Trans. power)
- Battery Charge Time: About 3,5 hours
- Hand-held Mic. Dimensions (W/DxH): Ø35 (min) - Ø46 (max) x 240 mm
- Hand-held Mic. Net Weight: 0.26 kg (batteries included)

J771J €155,90 £143.12



WF-D290HH MKII - UHF Dual Digital Wireless Microphone System

SOUNDSATION WF-D290 MKII adopts a brand-new digital transmission technology and hardware encryption of audio data that enable superior audio quality (compared to analog UHF systems), very-low latency (better than 2.4GHz systems) and maximum security due to the cryptographic hardware. The unique 16bit digital ID pilot technology avoids interferences even on same frequency, and allows continuous exchange of data between transmitters and receiver, such as battery level, transmission power, squelch operation, etc. The system is equipped with automatic frequency scanning and frequency spectrum display, which allow the user to select the less disturbed frequencies in every environment it operates. It features 90 frequencies for each transmitter, divided into 10 groups, each of which contains 9 channels. The user interface is very simple and intuitive, thanks to the TFT color display on the receiver and the simplicity of its setup menus. The handheld transmitter and the bodypack (in case of WF-D290HP), however, are equipped with LCD display with auto-off function, to save battery. The handheld microphone is also equipped with rechargeable lithium battery that can be recharged via the USB port on the back of the receiver. Finally, there are two optional kit for rack mounting of 1 or 2 receivers, respectively, on 1 or 2 standard 19" rack units.

- UHF E-Band operation (823-832 MHz)
- Digital audio transmission technology
- Unique digital 16-bit ID pilot technology
- Transmitter Audio level and Battery-Low monitoring on the Receiver
- Double antenna diversity technology
- No crosstalk disturbance even on same frequency
- Ultra-short audio latency
- Sampling Frequency:
- 30Hz-20kHz frequency response
- Colorful TFT display and menu settings on receiver
- Auto frequency scanning and spectrum display
- 50m Ideal Distance (without obstacles)
- Infrared Tx-Rx synchronization system for quick system setting
- Professional Handheld Microphone with Professional Dynamic Cardioid Capsule and rechargeable Lithium Battery
- Rack-Mount Kit for 1 or 2 receiver units to 1x or 2x 19" rack unit (optional)

- Carrier Frequency: UHF823-832 MHz
- Bandwidth: 9 MHz
- Channel Bandwidth: 100 kHz
- Preset Group/Channel: 10 groups, 9 frequencies in each group
- Dynamic Range: >98 dB
- Total Harmonic Distortion: <0.1%
- Frequency Response: 30 Hz-20 kHz/±2 dB
- Audio Output Level: Balanced 400mV; Unbalanced 400mV
- Packing Dimensions (WxHxD): 436x104x324 mm
- Packing Gross Weight: 2.5 kg
- Receiver Power Supply: DC 12V/1000 mA
- Receiver Consume Power: 5 W
- Signal/Noise Ratio: >98 dB
- Receiving Sensitivity: -95 dBm
- Transmission Delay: <3 ms
- Receiver Dimensions (WxHxD): 210x45x118 mm (antennas not incl.)
- Receiver Antennas: 255 mm (not bent) with BNC connectors
- Net Weight: 0.4 kg
- Transmitter Power: 10 mW (Max)
- Battery Voltage Handheld Transmitter: 1x3.7 V - 1200 mAh Lithium Rechargeable Battery (type 18500)
- Modulation Type: DQPSK
- Continuous Using: 5 hours (HI Trans. power); 7 hours (LO Trans. power)
- Battery Charge Time: About 3,5 hours
- Hand-held Mic. Dimensions (W/DxH): Ø35(min)-Ø46(max)x240 mm
- Hand-held Mic. Net Weight: 0.26 kg (batteries included)

J773J €199,88 £183.49





WF-D290HP - UHF Dual Digital Wireless Microphone System

SOUNDSATION WF-D290 adopts a brand-new digital transmission technology and hardware encryption of audio data that enable superior audio quality (compared to analog UHF systems), very-low latency (better than 2.4GHz systems) and maximum security due to the cryptographic hardware. The unique 16bit digital ID pilot technology avoids interferences even on same frequency, and allows continuous exchange of data between transmitters and receiver, such as battery level, transmission power, squelch operation, etc. The system is equipped with automatic frequency scanning and frequency spectrum display, which allow the user to select the less disturbed frequencies in every environment it operates. It features 90 frequencies for each transmitter, divided into 10 groups, each of which contains 9 channels. The user interface is very simple and intuitive, thanks to the TFT color display on the receiver and the simplicity of its setup menus. The handheld transmitter and the bodypack (in case of WF-D290HP), however, are equipped with LCD display with auto-off function, to save battery. The handheld microphone is also equipped with rechargeable lithium battery that can be recharged via the USB port on the back of the receiver. Finally, there are two optional kit for rack mounting of 1 or 2 receivers, respectively, on 1 or 2 standard 19" rack units.

- UHF E-Band operation (823-832 MHz)
- Digital audio transmission technology
- Unique digital 16-bit ID pilot technology
- Transmitter Audio-level and Battery-Low monitoring on the Receiver
- Double antenna diversity technology
- No crosstalk disturbance even on same frequency
- Ultra-short audio latency
- 48 kHz sampling frequency
- 30 Hz-20 kHz frequency response
- Colorful TFT display and menu settings on receiver
- Auto frequency scanning and spectrum display
- 50 m Ideal Distance (without obstacles)
- Professional Handheld Microphone with Professional Dynamic Cardioid Capsule and rechargeable Lithium Battery
- Body pack with Connector Locking System
- Infrared Tx-Rx synchronization system for quick system setting



- Carrier Frequency: UHF823-832 MHz
- Bandwidth: 9 MHz
- Channel Bandwidth: 100 kHz
- Preset Group/Channel: 10 groups, 9 frequencies in each group
- Dynamic Range: >98 dB
- Total Harmonic Distortion: <0.1%
- Frequency Response: 30 Hz-20 kHz/±2 dB
- Audio Output Level: Balanced 400 mV; Unbalanced 400 mV
- Packing Dimensions (WxHxD): 436x104x324 mm
- Packing Gross Weight: 2.5 kg
- Receiver Power Supply: DC 12V/1000 mA
- Receiver Consume Power: 5 W
- Signal/Noise Ratio: >98 dB
- Receiving Sensitivity: -95 dBm
- Transmission Delay: <3 ms
- Receiver Dimensions (WxHxD): 210x45x118 mm (antennas not incl.)
- Receiver Antenna: 255mm (not bent)
- Net Weight: 0.4 kg
- Transmitter Power: 10 mW (Max)
- Battery Voltage Handheld Transmitter: 1x3.7 V - 1200 mAh Lithium Rechargeable Battery (type 18500)
- Modulation Type: DQPSK
- Battery Voltage Bodypack Transmitter: 3 V (2x1.5 V AA Battery)

CODE	MODEL	PACK	MSRP EUR	MSRP GBP
E078E	WF-D290HP	1 hand-held mic+1 pocket transmitter	€198,24	£181.98



WF-D190P - 90-channel UHF Digital Wireless System with Bodypack and Headset

WF-D190 adopts a brand-new digital transmission technology and hardware encryption of audio data that enable superior audio quality compared to analog UHF systems, very-low latency (better than 2.4GHz systems) and maximum security due to the cryptographic hardware. The unique 16bit digital ID pilot technology avoids interferences even on same frequency, and allows continuous exchange of data between transmitter and receiver, such as battery level, transmission power, squelch operation, etc. The system is also equipped with automatic frequency scanning and frequency spectrum display, which allow the user to select the less disturbed frequencies in every environment it operates. It features 90 frequencies, divided into 15 groups, each of which contains 6 channels. The user interface is very simple and intuitive, thanks to the TFT color display on the receiver and the simplicity of its setup menus. The handheld transmitter and the bodypack, however, are equipped with LCD display with auto-off function, to save battery consumption. The handheld microphone is also equipped with rechargeable lithium battery that can be recharged via the USB port on the back of the receiver. Finally, two 19" rack mount kit are available to install 1 or 2 receivers, respectively, in 1 or 2 rack units.

- UHF E-Band operation (823-832 MHz)
- Digital audio transmission technology
- Unique digital 16-bit ID pilot technology
- Transmitter AF-level, Audio-level and Battery-Low monitoring on the Receiver
- Double antenna diversity technology
- No crosstalk disturbance even on same frequency
- Ultra-short audio latency
- 48kHz sampling frequency
- 30-20kHz frequency response
- Colorful TFT display and menu settings on receiver
- Auto frequency scanning and spectrum display
- 50m Ideal Distance (without obstacles)
- Infrared Tx-Rx synchronization system for quick system setting
- Professional Headset Microphone with Professional Dynamic Cardioid Capsule
- Rack-Mount Kit for 1 or 2 receiver units to 1x or 2x 19" rack unit (optional)

- System Carrier Frequency: UHF823-832MHz
- System Bandwidth: 9MHz
- System Channel Bandwidth: 100kHz
- Preset Group/Channel: 10 groups, 9 frequencies in each group
- Dynamic Range: >98dB
- Total Harmonic Distortion: <0.1%
- Frequency Response: 30Hz-20kHz / ±2dB
- Audio Output Level: Balanced 400mV; Unbalanced 400mV
- System Packing Dimensions (WxHxD): 436 x 104 x 324 mm
- System Packing Gross Weight: 2.5 kg
- Power Supply: DC 12V / 1000mA
- Receiver Consume Power: 5W
- Receiver Signal/Noise Ratio: >98dB
- Receiving Sensitivity: -95dBm
- Transmission Delay: <3ms
- Receiver Dimensions (WxHxD): 210 x 45 x 118 mm (antennas not incl.)
- Receiver Antennas: 255 mm (not bent)
- Receiver Net Weight: 0.4 kg
- Transmitter Power: 10mW (Max)
- Battery Voltage Bodypack Transmitter: 3V (2x1.5V AA Battery)
- Modulation Type: DQPSK
- Transmitter Continuous Using: 5 hours (HI Trans. power); 7 hours (LO Trans. power)
- Pocket Transmitter Dimensions (WxHxD): 62 x 103 x 30 mm
- Antenna (W/DxH): Ø3 x 9 mm
- Pocket Transmitter Net Weight: 0.132 kg (batteries included)

CODE	MSRP EUR	MSRP GBP
L922L	€152,56	£140.05



WF-U216 - UHF Dual 16-Channels Wireless Systems

The WF-U216 is a UHF dual wireless microphone system with 16 channels each. Its main characteristics are reliability, audio quality and extreme simplicity of use. It's been designed for all those professionals who need a ready-to-use tool, always. Despite its minimalist look, the WF-U216 is a concentrate of technology, capable of integrating a high-quality microphone preamp stage, a DSP-based audio processing, a PLL synthesis stage, and other functions in a single chip. Compared to analog systems, it significantly improves the stability and reliability of the FM modulation section, the AF and audio stages, offering professional level music performance. The WF-U216 is also equipped with the IR synchronization system, for quick coupling between the receiver and transmitter. Both the hand transmitter and the pocket transmitter can work with AA alkaline or rechargeable batteries. The handheld transmitter also allows direct charging of the batteries thanks to the supplied USB cable. The quality of the cardioid capsules of the handheld microphone (dynamic) is professional.

Common features

- 520-550MHz UHF Band
- 16-Channels for each Microphone (32-channels in total)
- Simple and Outright User Interface with display on Transmitters and Receiver
- Single-chip design with high-quality preamp, DSP audio processing, and PLL synthesis
- IR Matching System for Quick Setup
- High efficiency battery consumption design.
- 50m Ideal Distance (without obstacles)

Common specs

- Carrier Frequency: UHF 520-550MHz
- Frequency Stabilization: Automatic calibration
- Dynamic Range: >90dB
- Total Harmonic Distortion: <0.4%
- Frequency Response: 40Hz-15KHz ±3dB
- System Audio Output Level: Balanced 400mV; Unbalanced 400mV
- System Packing Dimensions (WxDxH): 380 x 285 x 65 mm
- Receiver Power Adapter: DC 12V / 1000mA
- Receiver Consume Power: <4W
- Receiver Signal/Noise Ratio: >95dB
- Receiving Sensitivity: -95dBuV
- Receiver De-Emphasis: 75uS
- Receiver Size (WxDxH): 210 x 155 x 43 mm
- Receiver Antennas Height: 115 mm
- Receiver Net Weight: 0.345 kg
- Transmitter Power: 10mW (Max)
- Transmitting Modulation Type: FM
- Transmission Max Deviation: ±26KHz
- Transmission Spurious Emission: >40dB
- Transmitter Battery Voltage: 2x1.5V AA Alkaline Batteries or 2x1.2V Rechargeable
- Transmitter Continuous Using: about 5 hours
-
-
- Pocket Transmitter Size (WxDxH): 62 x 30 x 103 mm
- Pocket Transmitter Antenna (W/DxH): Ø3 x 10 mm
- Pocket Transmitter Net Weight: 0.133 kg (batteries included)



WF-U216HH - UHF Dual 16-Channel Wireless System with two handheld microphones

- Professional Hand-held Microphone with Dynamic Cardioid Capsule

CODE	MSRP EUR	MSRP GBP
J242J	€131,07	£120.32



WF-U216HP - UHF Dual 16-Channel Wireless System with one handheld microphone and one headset with bodypack

- Professional Hand-held Microphone with Dynamic Cardioid Capsule
- Body-pack with 3-Pin Mini-XLR Connector and LCD display
- Professional and Lightweight Headset with High-Sensibility Condenser Cardioid Capsule

CODE	MSRP EUR	MSRP GBP
J243J	€134,34	£123.32



WF-U216PP - UHF Dual 16-Channel Wireless System with two headset mics and two bodypacks

- Body-pack with 3-Pin Mini-XLR Connector and LCD display (WF-U216HP and PP models only)
- Professional and Lightweight Headset with High-Sensibility Condenser Cardioid Capsule (WF-U216HP and PP models only)

CODE	MSRP EUR	MSRP GBP
J244J	€137,62	£126.34



WF-U24HP -

2x 4-Channel UHF wireless system with 1 receiver, 1 handheld mic., 1 pocket transmitter and 1 headset

WIREFREE series wireless systems adopt the fully integrated solution single chip, integrated microphone amplifier, audio based on DSP processor, PLL frequency synthesizer, etc. This allows us to offer highly professional performance yet cost-effective products to everyone.

- Dual 4-Channel UHF Receiver
- 1x 4-Channel UHF Handheld Transmitters with Professional Dynamic Cardioid Capsule
- 1x Pocket Transmitter and 1 Headset Microphone with Professional Condenser Cardioid Capsule
- SMT technology with surface mounting components
- Designed for professional live and educational purposes
- Unidirectional cardioid dynamic (handheld) and condenser (headset) microphone, clear and bright sound
- Special compression/expansion circuitry to greatly improve s/n ratio without affecting audio quality
- High efficiency batteries consumption design, in order to guarantee the use of the wireless microphone even after many hours
- Multiple noise control circuit, refuse to external interferences and the opening s/q system
- Carrier Frequency: ISM Europe (863-865 MHz). It doesn't need special license for use within European community.
- 19" standard rack mountable receiver using the optional kit WF-RACK KIT1 (single receiver in 1 19" rack unit) and WF-RACK KIT2 (2 receivers in 1 19" rack unit).

- Carrier Frequency: UHF 863-865MHz
- Frequencies: 863.000 MHz / 863.500 MHz / 864.000 MHz / 865.000 MHz
- Frequency Stabilization: Automatic calibration
- Dynamic Range: > 90dB
- Total Harmonic Distortion: < 0.4%
- Frequency Response: 40Hz-15KHz ±3dB
- Receiver Power Supply: DC17V - 300mA
- Receiver Power Consumption: < 4W
- Receiver Signal/Noise Ratio: > 95dB
- Receiving Sensitivity: >7dBuV (SINAD=30dB)
- Handheld Microphone / Body-pack Transmitter Power: 10mW
- Modulation Type: FM
- Max Deviation: ±20KHz
- Battery Voltage: 3V (2x1.5V AA Battery)
- Battery Continuum Using: 5 hours
- Packing Dimension (WxHxD): 375 x 285 x 65 mm
- Packing Gross Weight: 1.6kg
- Handheld Microphone Dimension (W/DxH): Ø53 x 255 mm
- Handheld Microphone Net Weight: 0.26kg (batteries included)
- Pocket Transmitter Antenna (W/DxH): Ø3 x 9 mm
- Pocket Transmitter Dimension (WxHxD): 62 x 103 x 30 mm
- Pocket Transmitter Net Weight: 0.135kg

CODE	MSRP EUR	MSRP GBP
B535B	€117,41	£107.78





WF-U11 Series

SOUNDSATION WF-11 is the answer to all those who need a reliable, high-quality sound, and easy to use wireless microphone system. Ideal in educational, Portable Sound, Public Address, and DJ contexts, the WF-11 impresses with its brilliant and warm sound, thanks to the quality of components and the capsule designed for all application.

- UHF Transmission with SMD Technology
- 4 available Frequencies in free-license ISM Europe Band
- Simple user Interface for plug and play setup
- 30m ideal distance (without obstacles)

- Carrier Frequency: UHF 863-865MHz
- Available Frequencies: 863.05 MHz, 864.15 MHz, 863.55 MHz, 865.00 MHz (WF-U11HB Freq. is 863.55 MHz)
- Frequency Stabilization: Automatic calibration
- Dynamic Range: > 90dB
- Total Harmonic Distortion: < 0.5%
- Frequency Response: 40 – 18500 Hz / ±3dB
- Power Supply: DC12V, 400mA
- Consumption: < 4W
- Signal/Noise Ratio: > 95dB
- Border Upon Channel Rejection: > 80dB
- Receiving Sensitivity: 10dBuV

- De-Emphasis: 75uS
- Audio Output Level: Balanced 400mV; Unbalanced 400mV
- Dimensions (WxHxD): 211 x 43 x 115 mm (antennas not incl.)
- Antenna: 120 mm (not bent)
- Net Weight: 0.295 kg
- Transmitter Power: 10mW
- Modulation Type: FM
- Deviation: 37KHz
- Spurious Emission: > 30dB
- Battery Voltage: 3V (2x1.5V AA-Type Batteries)
- Continuous Using: 5 hours

WF-U11P - UHF Plug & Play Wireless Microphone System with Bodypack and Headset (Freq. 863.05 MHz)

- Strong yet lightweight bodypack with professional headset microphone
- Professional and Lightweight Headset with high-sensitivity dynamic cardioid capsule
- Pocket Trans. Dimensions (WxHxD): 62 x 103 x 30 mm
- Antenna (W/DxH): Ø3 x 9 mm
- Pocket Transmitter Net Weight: 0.132 kg (batteries included)



WF-U11H - UHF Plug & Play Hand-Held Wireless Microphone System (Freq. 863.05 MHz)

- Handheld microphone with high-quality dynamic cardioid capsule
- Hand-held Mic. Dimensions (W/DxH): Ø33 (min) – Ø48 (max) x 240 mm
- Hand-held Mic. Net Weight: 0.218 kg (batteries included)



CODE	MODEL	FREQUENCY	MSRP EUR	MSRP GBP
L931L	WF-U11PA	863.05 MHz	€70,03	£64.29
E052E	WF-U11PB	863.55 MHz)	€70,03	£64.29
E053E	WF-U11PC	U864.15 MHz)	€70,03	£64.29
E054E	WF-U11PD	865.00 MHz)	€70,03	£64.29

CODE	MODEL	FREQUENCY	MSRP EUR	MSRP GBP
L923L	WF-U11HA	863.05 MHz	€68,45	£62.84
E049E	WF-U11HB	863.55 MHz)	€68,45	£62.84
E050E	WF-U11HC	864.15 MHz)	€68,45	£62.84
E051E	WF-U11HD	865.00 MHz)	€68,45	£62.84

WF-V11 - VHF Plug and Play Handheld Wireless Microphone (213.0 MHz) or Bodypack and headset

WF-V11 is the answer to all those who need a reliable, high-quality sound, and easy to use wireless microphone system. Ideal in educational, Portable Sound, Public Address, and DJ contexts, the WF-V11 impresses with its brilliant and warm sound, thanks to the quality of components and the capsule designed for all application.

- VHF Transmission with SMD Technology
- 4 available Frequencies in VHF Band
- Simple user Interface for plug and play setup
- 30m ideal distance (without obstacles)
- Handheld microphone with high-quality dynamic cardioid capsule
- Professional and Lightweight Headset with high-sensibility dynamic cardioid capsule

- Carrier Frequency: VHF 200 - 215.3 MHz
- Frequency Stabilization: Automatic calibration
- Dynamic Range: > 90dB
- Total Harmonic Distortion: < 0.5%
- Frequency Response: 40Hz - 16kHz / ±3dB
- Receiver Power Supply: DC12V, 500mA
- Receiver Consumption: < 2W
- Signal/Noise Ratio: > 95dB
- Receiving Sensitivity: 10dBuV
- De-Emphasis: 75uS
- Audio Output Level: Balanced 400mV; Unbalanced 400mV
- Receiver Size (WxHxD): 211 x 43 x 115 mm (antennas not incl.)
- Antenna Length: 110 mm (min.) 430 mm (max.)
- Net Weight: 0.295 kg
- Transmitter Power: 10mW
- Modulation Type: FM
- Deviation: 37KHz
- Battery Voltage: 3V (2x1.5V AA-Type Batteries)
- Continuous Using: 7 hours

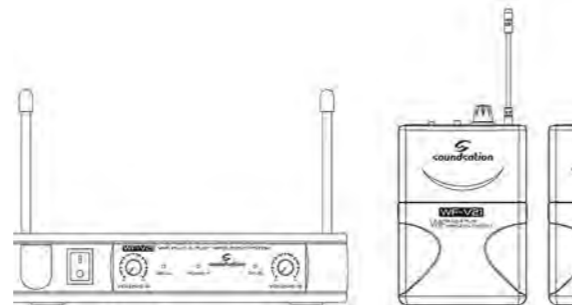

Handheld Mic

- Hand-held Mic. Size (W/DxH): Ø33 (min) - Ø48 (max) x 240 mm
- Hand-held Mic. Net Weight: 0.218 kg (batteries included)

Pocket Transmitter

- Pocket Trans. Dimensions (WxHxD): 62 x 103 x 30 mm
- Antenna (W/DxH): Ø3 x 9 mm
- Pocket Transmitter Net Weight: 0.132 kg (batteries included)

CODE	MODEL	OP. FREQUENCY	MSRP EUR	MSRP GBP	CODE	MODEL	OP. FREQUENCY	MSRP EUR	MSRP GBP
E450E	WF-V11HA	Operating Frequency: 213.0 MHz	€56,01	£51.42	E454E	WF-V11PA	Operating Frequency: 213.0 MHz	€57,58	£52.86
E451E	WF-V11HB	Operating Frequency: 215.5 MHz	€56,01	£51.42	E455E	WF-V11PB	Operating Frequency: 215.5 MHz	€57,58	£52.86
E452E	WF-V11HC	Operating Frequency: 205.75 MHz	€56,01	£51.42	E456E	WF-V11PC	Operating Frequency: 205.75 MHz	€57,58	£52.86
E453E	WF-V11HD	Operating Frequency: 209.8 MHz	€56,01	£51.42	E457E	WF-V11PD	Operating Frequency: 209.8 MHz	€57,58	£52.86

WF-V21 - Dual VHF Plug and Play Wireless Microphone with 2 Handheld Mics (213.0 MHz - 215.5 MHz) or Bodypack and headset

WF-V21 is the answer to all those who need a reliable, high-quality sound, and easy to use set of wireless microphones. Ideal in educational, Portable Sound, Public Address, and DJ contexts, the WF-V21 impresses with its brilliant and warm sound, thanks to the quality of components and the capsule designed for all application.

- VHF Transmission with SMD Technology
- 2 available Pairs of Frequencies in VHF Band
- Simple user Interface for plug and play setup
- 30m ideal distance (without obstacles)
- 2 Handheld microphones with high-quality dynamic cardioid capsules
- Professional and Lightweight Headsets with high-sensibility dynamic cardioid capsules

- Carrier Frequency: VHF 200 - 215.3 MHz
- Frequency Stabilization: Automatic calibration
- Dynamic Range: > 90dB
- Total Harmonic Distortion: < 0.5%
- Frequency Response: 40Hz - 16kHz / ±3dB
- Receiver Power Supply: DC12V, 500mA
- Receiver Consumption: < 4W
- Signal/Noise Ratio: > 95dB
- Receiving Sensitivity: 10dBuV
- De-Emphasis: 75uS
- Audio Output Level: Balanced 400mV; Unbalanced 400mV
- Receiver Size (WxHxD): 211 x 43 x 115 mm (antennas not incl.)
- Antenna Length: 110 mm (min.) 430 mm (max.)
- Net Weight: 0.295 kg
- Transmitter Power: 10mW
- Modulation Type: FM
- Deviation: 37KHz
- Battery Voltage: 3V (2x1.5V AA-Type Batteries)
- Continuous Using: 7 hours

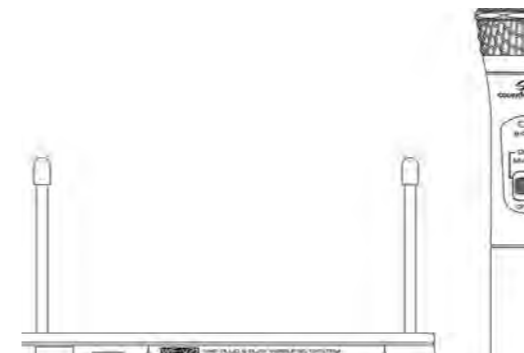

Handheld Mic

- Hand-held Mic. Size (W/DxH): Ø33 (min) - Ø48 (max) x 240 mm
- Hand-held Mic. Net Weight: 0.218 kg (batteries included)

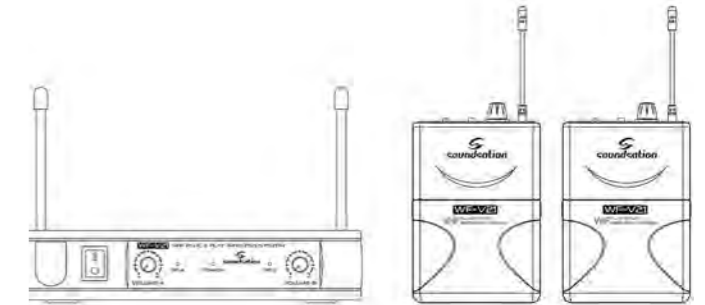

Pocket Transmitter

- Pocket Trans. Dimensions (WxHxD): 62 x 103 x 30 mm
- Antenna (W/DxH): Ø3 x 9 mm
- Pocket Transmitter Net Weight: 0.132 kg (batteries included)

CODE	MODEL	OP. FREQUENCY	MSRP EUR	MSRP GBP	CODE	MODEL	OP. FREQUENCY	MSRP EUR	MSRP GBP
E458E	WF-V21HHA	Operating Frequencies: 213.0 MHz - 215.5 MHz	€74,68	£68.56	E460E	WF-V21PPA	Operating Frequencies: 213.0 MHz - 215.5 MHz	€77,79	£71.41
E459E	WF-V21HHB	Operating Frequencies: 205.75 MHz - 209.8 MHz	€74,68	£68.56	E461E	WF-V21PPB	Operating Frequencies: 205.75 MHz - 209.8 MHz	€77,79	£71.41

WF-DA100 KIT - Kit composed by UHF Wideband active directional antenna, and tripod stand

WF-DA100 is a directional antenna for professional receiving within UHF range. Optimized for 400MHz~1000MHz, it has a 4~6dBi high directional characteristic which is ideal for the environment that needs specific direction usage. The most unique feature is connected to receivers directly. Besides, it is built with a 15dB high gain booster specifically for long distance receiving, compensate for coaxial cable connected to the receiver caused. The power of the amplifier is derived from the coaxial cable connected to the antenna divider or to UHF receivers kit includes an adjustable tripod stand.

- Bandwidth: 400MHz - 1000MHz
- Gain: 4-6 dBi
- Amplifier Gain: 15±1dB
- VSWR (Voltage Standing Wave Ratio): 2:1
- 3dB beam width: 75°vertical polarization plane and horizontal polarization
- Power consumption: 200mW
- Antenna connector: BNC female
- Size(WxHxD): 31x3x30,5cm
- Packing Size(WxHxD): 36,9x5,7x36,1cm
- Weight: 0,45kg



CODE MSRP EUR MSRP GBP
E575E €180,47 £165.67

WF-AA10 - Wideband UHF antenna amplifier

Optimized in the 470 ~ 1000 MHz frequency range, the WF-AA10 offers 12dB (±1 dB) gain to compensate for signal loss due to long antenna cables, thereby enhancing signal stability and increasing reception range. With an external power supply, the WF-AA10 provides power independently to the internal antenna amplifier. This allows complicated external antenna dividing systems to work efficiently and independently so that longer antenna cables can be connected with more amplifiers. Its aluminum casing provides superb heat dissipation characteristics.

- External Power Input: 12÷24V DC (Min. 350mA)
- Regulated Supply Output: 9V DC (Max. 250mA)
- Bandwidth: 470MHz ÷ 1000MHz
- IIP3: +18dBm
- Gain: +12dB (±1dB)
- Noise Index: < 2.5dB
- Impedance: 50 Ohm
- Accessories: 1 x AC/DC Adapter, 1 x User manual
- Dimensions(WxHxD): 93x26x55mm
- Weight: 0.17Kg



CODE MSRP EUR MSRP GBP
E563E €76,25 £70.00

WF-AD100 - UHF Wideband antenna divider system with 2 Inputs and 8 Outputs

WF-AD100 is optimized for the carrier frequency 470 ~ 1000 MHz and is capable of handling 2 ~ 4 sets of UHF receivers with diversity to operate from a simple pair of antennas, greatly simplifying the antenna installations and increasing the distance and reception efficiency. It adopts the latest range of high dynamic and low noise components with advanced circuit design so as to have very low modulation distortion and the elimination of spurious interference in the use of multiple systems. The output gain of the system is approximately equal to 1. It comes with 2 sets of antenna Input/Output connectors (BNC female) and 2 sets of 4-channel antenna output connectors (BNC female) for direct connection to 4 groups of receivers with diversity.

- Power Supply: 12÷15V DC
- Bandwidth: 470MHz ÷ 1000MHz
- IIP3: +32dBm
- RF Output Gain: +0.1dB ÷ +1dB
- Input-Output Gain: +0.1dB ÷ +1dB
- Output Isolation Rate: > 18dB between 470 ÷ 1000MHz
- Band Selecting: Low end > 35dB; High end > 30dB
- Input-Output Impedance: 50 Ohm
- Antenna connectors: BNC Female
- Accessories: 10 x BNC-BNC signal cables (50cm) ; 1 x AC/DC Adapter ; 2 x Rack Mount Brackets ; 1 x User manual
- Dimensions(WxHxD): 420x45x240mm - Weight: 1,8Kg



CODE MSRP EUR MSRP GBP
E562E €255,15 £234.23

**WF-RACK KIT2
19" Rack Mount Kit for WireFree Series Wireless Systems**

The kit allows you to mount a 1/2 receiver unit in a standard 19 "rack. It includes 1x 19" rack unit panel; 2x Lateral brackets; 4x Receiver coupling brackets; 4x Extension cables for Antenna and screws to fasten the two receiver each other and then to the rack adapters



■ The kit doesn't include screws to fasten the whole block (receiver and adapters) to the 19" rack chassis.

CODE MSRP EUR MSRP GBP
B390B €39,49 £36.25

**WF-RACK KIT1
19" Rack Mount Kit for WireFree Series Wireless Systems**

The kit allows you to mount a 1/2 receiver unit in a standard 19 "rack. It includes 2x 1/4 rack unit adapters; 2x Extension cables for Antenna; Screws to fasten the receiver to the two rack adapters.



■ The kit doesn't include screws to fasten the whole block (receiver and adapters) to the 19" rack chassis.

CODE MSRP EUR MSRP GBP
A892A €20,27 £18.61

VISAGE SERIES

Soundsation Visage C01 Headset microphone is the right balance between elegance, flexibility, discretion and strength. It allows singers, musicians, actors, public speakers, broadcast professionals, to move freely during their performance and always guarantee an accurate capture of the voice. The frequency response and the excellent plosive attenuation, allow you to obtain a warm and sparkling sound, without unnatural emphasis.

- Back-electret high-performance capsule for professional audio quality
- Designed for withstand very close sound sources (provides off-axis rejection to high SPL sounds)
- Cardioid pattern for accurate voice capture and minimum room noise
- Waterproof selected material for maximum duration in any application
- Microphone arm and cable are easily attached to frame
- Special rubber material ear-set for perfect adherence to ear shape
- Left or right microphone placement according to user preference
- Black or Beige Color
- 4 connector types available
- Headset bag for better preserve the microphone

- Element: Back-Electret Capsule
- Directivity: Unidirectional
- Frequency Range: 45Hz~19.6kHz
- Sensitivity: -46dBV(±3dB)
- Maximum SPL: 125dB
- Output Impedance: 200Ω
- Operation Voltage: DC 1.5~9V
- Connector Type A = 1.8" TS Mini-Jack with thread
- Connector Type B = 1.8" TRS Mini-Jack with locking (Sennheiser®)
- Connector Type C = 3-Pin Mini-XLR (AKG®)
- Connector Type D = 4-Pin Mini-XLR (SHURE®)*
- Cable Length: 1.5m
- Color: Black or Beige
- Headset Weight: 28g

*SHURE type connect includes a 2.2kohm resistor between pin 2 and 3.

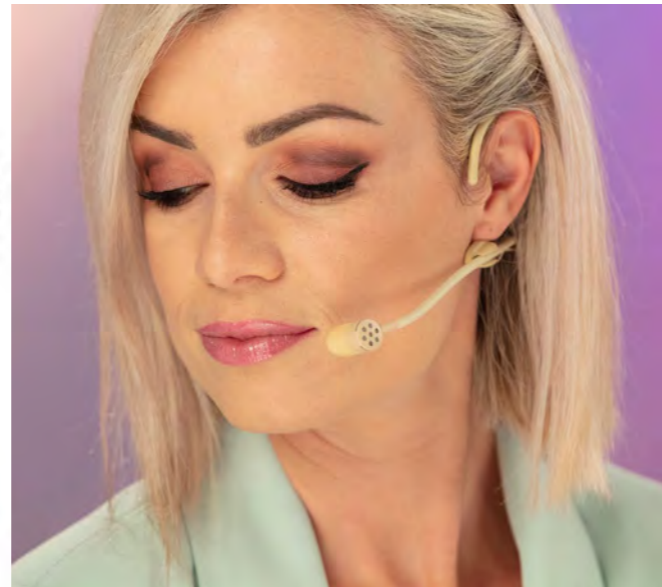

J633J	VISAGE-C01A BK	Cardioide Headset Mic., 1.8" TS Mini-Jack with thread, Black	€27,84	£25.56
J634J	VISAGE-C01B BK	Cardioid Headset Mic., 1.8" TRS Mini-Jack with locking, Black (Sennheiser® type)	€27,84	£25.56
J635J	VISAGE-C01C BK	Cardioid Headset Mic., 3-Pin Mini-XLR, Black (AKG® type)	€27,84	£25.56
J636J	VISAGE-C01D BK	Cardioide Headset Mic., 4-Pin Mini-XLR, Black, Black (Shure® type)	€27,84	£25.56
J637J	VISAGE-C01A BG	Cardioide Headset Microphone, 1.8" TS Mini-Jack with thread, Beige	€27,84	£25.56
J638J	VISAGE-C01B BG	Cardioid Headset Mic., 1.8" TRS Mini-Jack with locking, Beige (Sennheiser® type)	€27,84	£25.56
J639J	VISAGE-C01C BG	Cardioide Headset Mic., 3-Pin Mini-XLR, Black, Beige (AKG® type)	€27,84	£25.56
J640J	VISAGE-C01D BG	Cardioide Headset Mic., 4-Pin Mini-XLR, Black, Beige (Shure® type)	€27,84	£25.56
J821J	VISAGE-C01E BK	Cardioid Headset Mic., 3-Pin Mini-XLR, Black (for Soundsation WF-D190-D290)	€27,84	£25.56
J822J	VISAGE-C01E BG	Cardioide Headset Mic., 3-Pin Mini-XLR, Beige (for Soundsation WF-D190-D290)	€27,84	£25.56

NEW

VOXTAKER 30 KIT - USB CONDENSER STUDIO MICROPHONE KIT

The VoxTaker-30 KIT includes a "plug and play" studio recording microphone with condenser capsule that can be used without having to install any drivers. By simply connecting a USB cable, you can fulfill a variety of music production applications quickly and easily as the microphone is compatible with all recording software and ASIO audio drivers. The VoxTaker-30 microphone uses high-performance USB chip technology, high-quality single-point capacitive transducers and is capable of delivering a warm yet detailed sound suitable for human voice, music, podcasts and personal recordings. The VoxTaker-30 microphone is powered by the USB port of the device to which it is connected. This means you can normally just plug in your microphone and start using it right away. For non-standard USB ports, a powered USB hub may be required. The VoxTaker-30 microphone is a "Plug & Play" USB device, compatible with Windows® and Mac® computers, without having to install any drivers. The VoxTaker-30 KIT also includes a pop filter with flexible arm for adjustment, a shock-mount microphone holder, a solid circular base and a small pole for installation.

- High quality condenser capsule
- Cardioid Uni-Directional Polar Pattern
- High Quality JFET Preamp
- Strong Output Signal without Distortion
- High-speed AD conversion technology
- Sampling rate up to 48 kHz
- 16 Bit Resolution
- USB 2.0 Plug and Play Operation

- Maximum compatibility with Windows® and Mac® OS computers without any drivers
- Low Power Consumption
- High Absorption Shock-mount
- Pop Filter with flexible arm
- Sturdy circular metal base
- Small pole for installation

- Element: 14mm High quality condenser capsule
- Polar pattern: Cardioid Uni-Directional
- Frequency response: 20Hz-18KHz
- Sensitivity: -36dB+/-2dB (0dB=1V/Pa at 1KHz)
- Sampling rate: 48KHz / 16Bit
- Load Impedance: =10000
- Self-Noise: 16dB A-weighted
- Max Input SPL: 130dB (at 1KHz)
- S/N Ratio: 78dB
- Microphone Dimension: Length: 155 mm - Diameter: 50mm
- Microphone Weight: 0.37 Kg
- Pop Filter Diameter: 130 mm
- Pop Filter Arm Length: 360 mm
- Metal base diameter: 150 mm
- Metal base weight: 0,81 Kg
- Installation pole length: 165 mm
- USB Cable Length: 1800 mm

CODE	MSRP EUR	MSRP GBP
L849L	€88,52	£81.26



VOXTAKER series

VOXTAKER 192 PRO - Premium Quality 192kHz/24bit USB Studio Microphone Kit

VoxTaker 192 PRO is a groundbreaking technology studio microphone for professional recording. It combines dual high-precision large diaphragm condenser capsule, precision FET pre-amplification circuitry, real 24Bit/192kHz sampling accuracy, and USB 2.0 high-speed audio processing chip. It is compatible with all recording software and ASIO audio drivers and offers a professional driver interface with the newest 2.0 class audio device definition. The built-in monitor interface with 3.5mm stereo headphone jack, volume and Gain controls, provides real-time zero latency monitoring for maximum comfort during recording. The transducing element is a dual-condenser golden-plated large diaphragm capsule with selection of Uni/Bi/Omni-directional polar pattern. All these features make the VoxTaker 192 PRO the perfect tool for any capturing need: from human voice to acoustic instrument miking, to background music and choral recording. It is a real helper for music creation.

- Professional 34mm Pressure Gradient Transducer
- Selectable Uni/Dual/Omni Directional Polar Patterns
- High Quality FET Preamp
- Strong Output Signal without Distortion
- High-speed AD/DA conversion technology
- Up to 192kHz Sample Frequency (192kHz can only be used under USB 2.0 fast mode)
- Up to 24bit Resolution
- USB 2.0 high-speed and full-speed modes compatible
- Zero latency monitoring and Hi-Fi recording
- Maximum compatibility with Windows and Mac OS computers
- Compatible with variety of recording applications and ASIO audio driver
- Low Power Consumption

- Element: 34mm Pressure Gradient Condenser Transducer
- Polar Pattern: Uni/Dual/Omni Directional, selectable
- Frequency Response: 20Hz~20KHz
- Sensitivity: -34dB ±2dB (0dB=1V/Pa @ 1kHz)
- Max. Input SPL: 132dB (@ 1kHz = 1% T.H.D.)
- Output Impedance: 150 ohm ±30% (@ 1kHz)
- Load Impedance: = 1000 ohm
- Self-Noise: 16dB A-weighted
- S/N Ratio: 78dB
- Power Requirement: USB Power
- Microphone Size (WxHxD): 188x50x50 mm
- Microphone Weight: 252 g
- 24 Bit AD/DA fast conversion
- USB 2.0 high speed audio processing chip
- 16/24Bit sampling resolution, with 44.1k/48k/96k/192kHz (192kHz can only be used under USB2.0 fast mode)
- Embed USB2.0 transceiver (bandwidth is up to 480MB)

CODE **MSRP EUR** **MSRP GBP**
E256E **€217,12** **£199.32**



DIAGRAMMA POLARE

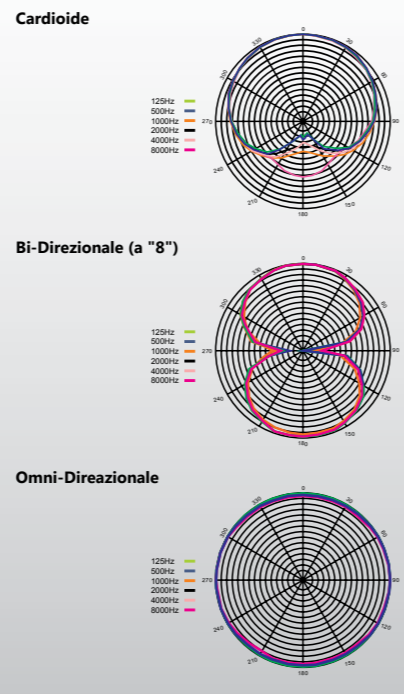

VOXTAKER series

VOXTAKER 100 USB - Condenser Studio Microphone with Cardioid Polar Pattern and USB Interface

VoxTaker 100 USB is a plug and play condenser studio recording microphone, without having to install any driver. Like the VoxTaker 100, it is a professional microphone featuring true condenser capsule with cardioid polar pattern. It can be used with confidence in a variety of professional applications, such as recording studios, broadcasting, podcasting, and stage performances just connecting a USB cable. It is compatible with all recording software and ASIO audio drivers. It uses high-performance USB chip technology and high-quality single-point capacitive transducers. That's why the VoxTaker 100 USB has very low self-noise and high output to reproduce even the subtle sound and fulfil the requirement of high sound quality for broadcasting and recording. The package includes Shock-Mount, Pop Filter and USB cable, all inside a plastic case.

- Professional Pressure Gradient Transducer
- Cardioid Polar Pattern
- High Quality FET Preamp
- Strong Output Signal without Distortion
- High-speed AD/DA conversion technology
- 44.1/48 kHz Sample Frequency
- 16 Bit Resolution
- USB 2.0 Plug and Play Operation
- Maximum compatibility with all Operative Systems without any drivers
- Low Power Consumption
- High Absorption Shock-mount
- Stylish and Innovative Pop Filter
- Package includes Plastic Case and USB cable



- Element: 16mm high-sensitivity condenser capsule
- Cardioid Polar Pattern
- Frequency Response: 30Hz -20kHz
- Sensitivity: -34dB (0dB = 1V/Pa at 1kHz)
- Max Input SPL: 130dB (at 1kHz 1% T.H.D.)
- 16bit A/D-D/A conversion resolution
- Stereo ADC/DAC operation
- USB 2.0 transceiver
- ADC sampling frequency: 8k, 11.025k, 16k, 22.05k, 32k, 44.1k, 48kHz
- ADC THD+N = 0.01%
- ADC S/N Ratio = 89dB
- ADC Dynamic Range = 89dB
- DAC frequency: 32k, 44.1k, 48kHz
- DAC THD+N = 0.005% - DAC S/N Ratio = 96dB
- DAC Dynamic Range = 93dB
- Stereo output power: 400mW
- Microphone Size (WxHxD): 188x50x50 mm
- Microphone Weight: 252 g
- Case Size (WxHxD): 340 x 280 x 90 mm

CODE **MSRP EUR** **MSRP GBP**
L999L **€94,20** **£86.48**



FREQUENCY RESPONSE GRAPH

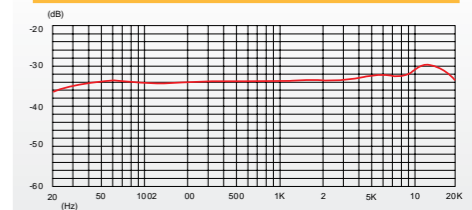

POLAR PATTERN GRAPH

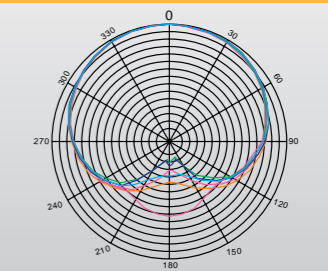

VOXTAKER series

VOXTAKER 100 - Large-diaphragm Studio Microphone with Cardioid Polar Pattern

Professional condenser microphone featuring true condenser capsule with cardioid polar pattern. It can be used with confidence in a variety of professional applications, such as recording studios, broadcasting, podcasting, and stage performances. With its gold-plated diaphragm capsule and premium FET preamp circuitry, VoxTaker 100 has very low self-noise and high output, to reproduce even the subtle sound and fulfil the requirement of high sound quality for broadcasting and recording. The package includes Shock-Mount and Pop Filter, all inside a plastic case.

- 34mm Gold-Plated Pressure Gradient Transducer
- Cardioid Polar Pattern
- High Quality FET Preamp Stage
- High Absorption Shock-mount
- Stylish and Innovative Pop Filter
- Plastic Case



- Element: 34mm pressure gradient capsule
- Cardioid Polar Pattern
- Frequency Response: 30Hz - 20kHz
- Sensitivity: -38dB (0dB = 1V/Pa at 1kHz)
- Output Impedance: 150 (at 1kHz)
- Load Impedance: 1000 ohms
- Self-Noise: 16dB A-weighted
- Max Input SPL: 130dB (@ 1kHz - 1% T.H.D.)
- S/N Ratio: 78dB
- Microphone Size (WxHxD): 188x50x50 mm
- Microphone Weight: 272 g
- Case Size (WxHxD): 340 x 280 x 90 mm
- Package Weight (Mic., case and accessories): 1.5kg

CODE **MSRP EUR** **MSRP GBP**
L998L €86,48 £79.39

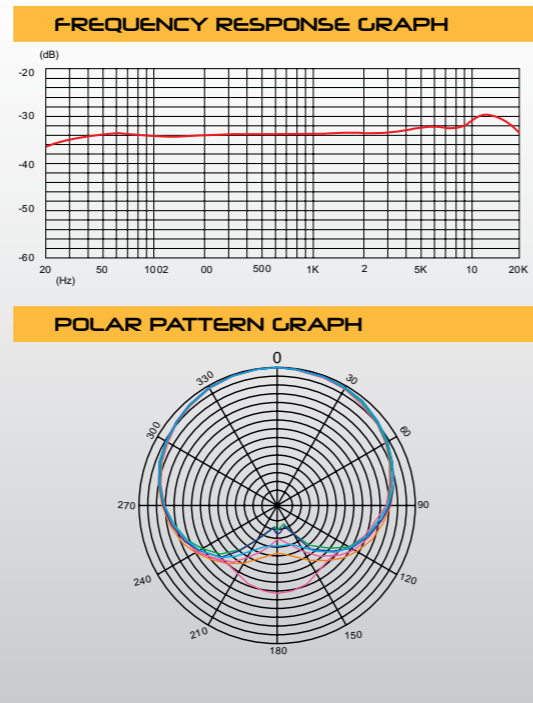

PCM-6000 PRO - Small Diaphragm "Pencil" Condenser Microphone

PCM-6000 Pro is a 16mm diaphragm condenser microphone suitable for recording acoustic instruments, drum overheads, cymbals and live performances. The kit includes two capsules, respectively with cardioid pickup pattern, and omni-directional pattern, which make this microphone ideal for use in indoor or outdoor applications, and for single instruments, choirs or ambience miking. Its metal case is extremely light and rugged, and its small and short design permits flexible and easy positioning. The microphone requires phantom power of 9V to 52V. The kit includes also a padded Zip Pouch, microphone clip, and pop filter.

- Ideal for overhead, Choir, Hi-Hat, Cymbals, Percussion, Orchestra and Piano
- D16mm High Quality Head-grille
- Premium Quality Preamp Circuitry
- High Sensitivity and Low Self-Noise
- Polar pattern: cardioid + Omni-Directional (interchangeable cartridges)
- Color: Satin Black
- Includes pop-filter and Mic holder

- Element: 16mm condenser head-grille
- Frequency Response: 30Hz-20KHz
- Sensitivity: -38dB +/-2dB (0dB=1V/Pa @ 1KHz)
- Output Impedance: 100ohm
- Self-Noise: 24dBA
- Max Input SPL: 136dB (at 1KHz +/- 1% T.H.D.)
- S/N Ratio: 76dB
- Power Requirement: 9-52V Phantom Power

CODE **MSRP EUR** **MSRP GBP**
E574E €53,01 £48.66

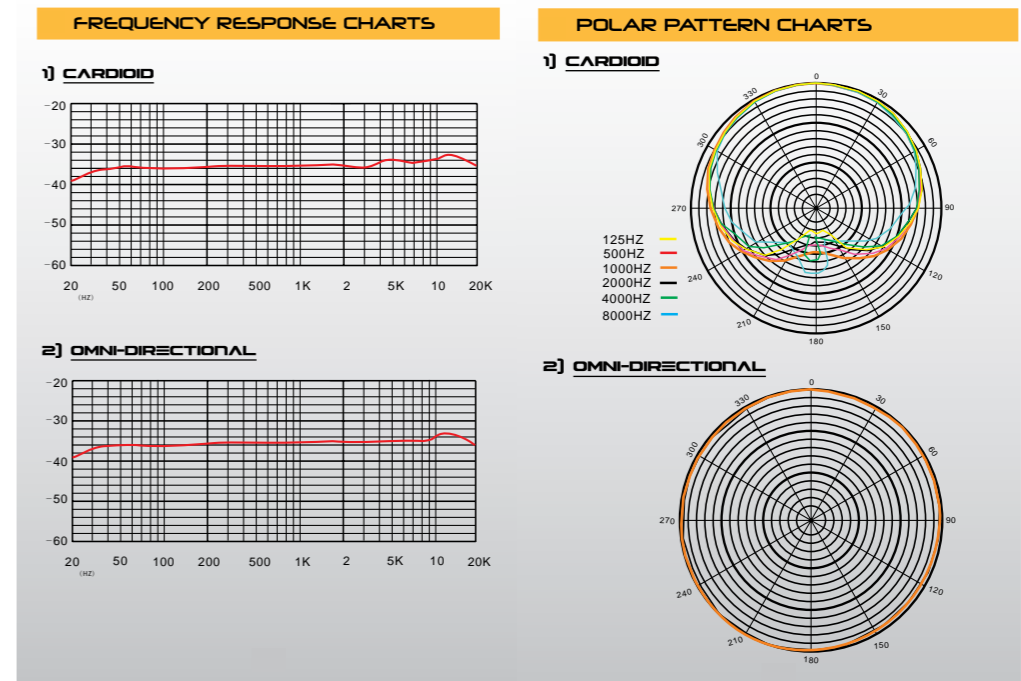

SGC120-MKII - Dual Powered Condenser Shotgun Microphone

SOUNDSATION SGC120 is a dual powered (9V battery or phantom power) shotgun condenser microphone for studio or mobile use. You can use it for capturing vocals and acoustic instruments as well. A right choice also for interviews, on-camera voice reproduction and broadcasts. It features two switchable polar patterns, cardioid and hypercardioid which offer the flexibility of using the microphone with close-up or extended on axis response.

- Dual directivity option (cardioid or hyper-cardioid)
- Detailed and clear voice pickup
- Dual power - user can choice to use 9V battery or phantom power +48
- High sensitivity, wide dynamic range and low distortion
- Spring cable for flexible in-field performance
- Ideal for video camera ,ensemble voice miking, acoustic instruments, interviewing apps
- Comes with cable and windscreen

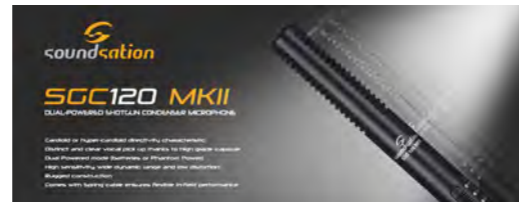

- Elements: Back Electret Condenser
- Polar pattern: Cardioid / Hypercardioid
- Frequency: 50Hz~16kHz/ 80Hz~14kHz
- Sensitivity: -45dB/-30 dB±2dB(OdB=1V/Pa at 1kHz)
- Output Impedance: 500ohm±30%(at 1kHz)
- Battery Type: AA/UM3, 1.5V
- Cable specs : XLR M to stereo 3.5" connector (minijack) , 1 mt lenght, spring cord

CODE	MSRP EUR	MSRP GBP
I810I	€71,24	£65.40



CamAudioPRO - Camera Recording Microphone

SOUNDSATION CamAudioPRO is a professional shotgun microphone for camcorders, digital cameras and portable audio recorders. It mounts a high-performance condenser capsule delivering HD Audio quality . The cardioid design of polar pattern ensure isolation of the sound source from other off-axis ambience sounds. The connection to the video device is obtained through a standard 3.5mm male minijack connector. CamaudioPRO is designed to avoid vibrations, thanks to its schock proof mounting system. User selectable functions of high-pass filter and a gain switch able to increase the output signal level of +10dB allow a total control of the acquired sound source. The power is supplied by a 9V alkaline battery (provided in the product box) that is able to guarantee over 100 hours of recording. The replacement of the battery when expired is a very easy operation. CamaudioPRO can be connected to any standard viedo equipment providing a 3/8" thread base mount system. Suitable for all kind of indoor or outdoor applications.

- High sensitivity condenser microphone delivering HD Audio
- Cardioid polar pattern isolate the main sound source from other ambience sound
- Easy mount on any standard video device through 3/8 thread system
- Shock proof design can reduce the mechanical noise of cameras and other vibration noise
- Gain switch for increasing +10dB output signal level and 200Hz bass filter meet the demand of different applications
- Rugged mic housing features effective EMI resistance
- Powered by 1.5V AA alkaline battery, playtime is up to 100hrs
- Low power indicator
- Comes with windscreen and velvet black carrying

- Transducer Principle: Back Electret Condenser
- Directivity Characteristic: Cardioid
- Frequency Response: 50Hz-16KHz
- Sensitivity: -32dB±3dB(OdB=1V/Pa at 1KHz)
- Gain Switch: +10dB
- Bass Filter: 60Hz 10dB/octave
- Output Impedance: 2000Ω±30%
- Power Requirement: 1.5V AA battery
- Dimensions: cm 20x5x3 - Net weight: 450 g

CODE	MSRP EUR	MSRP GBP
I510I	€61,45	£56.41



PCM-8000 MATCH - Small Diaphragm Matched Condenser Microphone Pair

PCM-8000 MATCH is a set of two condenser microphones with a 16 mm diaphragm, designed for stereophonic miking of acoustic instruments, overall shots for drums, choirs and live performances. The microphones are matched with tolerance within 1dB, and are equipped with 0dB/-10dB gain selector and 100Hz low-cut filter to adapt to all sources and mic preamps (+48V phantom power is required). The kit - contained in a practical plastic case with protective padding, in addition to the two microphones, includes two shock-mounts with screw adapters from 3/8 "to 5/8", distance bar, and two pop-filters. The pressure gradient capsule with cardioid polar pattern is based on a 16mm gold-plated diaphragm. The process of plating with gold vapors deposited on the surface, gives lightness, an excellent electrical capacity and a linear frequency response. The body of the microphone, in lightweight and sturdy metal, contains the JFET preamplifier to maintain a high isolation between input and output stage, and low self-noise.

- Ideal for Stereo Overhead, Choir, Cymbals, Percussion, Acoustic Instruments, and Piano
- 16mm High-Quality Pressure Gradient Transducer
- Vapor-Deposited Gold Diaphragm
- Premium Quality Preamp Circuitry
- High Sensitivity and Low Self-Noise
- Cardioid Polar pattern
- Linear Frequency Response
- The Kit Includes 2x Matched Microphones, 2x Shock-Mount Mic Holders, 2 Pop-Filters, and 1 Adjustable Stereo Bar



- Element: Pressure Gradient Transducer
- Polar Pattern: Uni-directional (Cardioid)
- Frequency Response: 30Hz-20kHz
- Match Tolerance: Within 1dB (from 100Hz to 10kHz - excluding 1kHz)
- Sensitivity: -38dB+/-2dB (OdB=1V/Pa @ 1kHz)
- Output impedance: 100ohm +/- 30% @ 1kHz
- Self-Noise: 16dB (A-weighted)
- Max. input SPL: 130dB (@ 1 kHz = 1% T.H.D)
- S/N Ratio: 78dB
- Input Attenuation: 0dB/-10dB Selector
- Low frequency attenuation: 100Hz 12dB/Octave
- Power Requirement: +48V Phantom Power

CODE	MSRP EUR	MSRP GBP
J023J	€125,66	£115.36

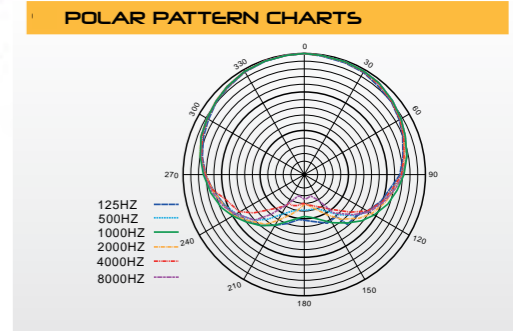
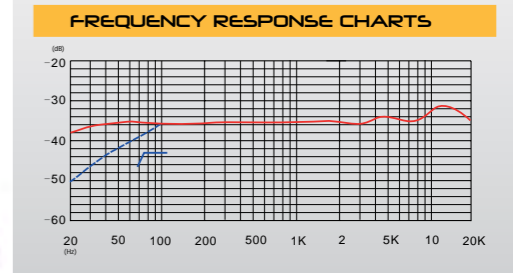

VOCAL 300 PRO 3P - Set of 3 VOCAL 300 PRO dynamic microphones

SOUNDSATION VOCAL series of microphones is the perfect answer to all those users who require rugged and reliable tools, able to improve the range of frequencies typical of male and female voices, and wink at its own wallet. VOCAL 300 PRO 3P is a set of 3 VOCAL 300 PRO professional dynamic microphones, 3 adapters for microphone stands, all in a handy padded carrying case. It is an excellent tool for miking purposes, where there are several voices or instruments and you want a professional dynamic transducer with cardioid polar pattern, high sensitivity, wide frequency response and and high sound pressure capability.

- 3 Dynamic vocal microphone with smooth mid-frequency presence rise for excellent voice reproduction
- Wide frequency response for crystal yet clear sound
- High signal output, lets your voice cut through
- Cardioid polar pattern minimizes ambient noise and feedback
- On/off switch
- 3 Microphone stand adapters included
- High-quality components and exceptionally rugged construction

- Type: Dynamic
- Directivity: Cardioid
- Polar Pattern: Uni-Directional
- Frequency Response: 68Hz - 17.2kHz (±3dB)
- Sensitivity: -60dB ±3dB (0dB=1V/Pa @ 1kHz)
- Output impedance: 300ohms, ±15%
- Microphone Size (HxDiameter): 29,5 x D50,5 max. x D22,5 min. cm
- Plastic Box Size (LxHxD): 25,6 x 12,2 x 8 cm
- Microphone Weight: 0.29kg

CODE	MSRP EUR	MSRP GBP
L806L	€42,37	£38.90

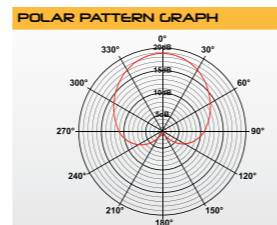
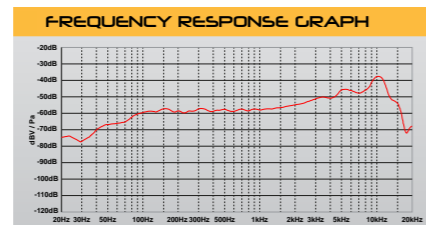

MICPKG-200 - Vocalist all-in-one package with carrying bag

Soundsation mic pack is a complete kit for vocalist including a metal body dynamic mic, 6 mt XLR cable and a boom mic stand. A padded carrying bag, brings an all-in-one easy solution for musicians on the road or rental companies

- Unidirectional dynamic microphone with metal body and zip bag
- Telescopic boom mic stand with extra strong tripod base.
- Clamp to attach the microphone to the stand
- 6 meter OFC shielded mic cable, 2 XLR plugs
- Padded carrying bag with zip pocket to protect the microphone

- Stand height without boom (max): 135 cm
- Stand boom lenght (min-max): 53-91 cm
- Stand weight: 2,3 Kg
- Mic body material: metal
- Mic transducer: dynamic
- Mic Polare pattern: unidirectional
- Mic Frequency Response: 50Hz-16KHz
- Mic sensitivity: -54dB+/-3dB
- Output impedance: 600 OHM +/30%

CODE	MSRP EUR	MSRP GBP
D794D	€60,10	£55.17



DSKIT-7 - Acoustic Drumset Microphone Kit

New Soundsation DSKIT-7 is a prime solution to mike your acoustic drum-set. New reduced size designed microphones give them a better cosmetic appeal and discretion in comparison to the used drum-set. Ideal for modern drummers, this kit gives max reliability both live performances and studio recording applications. Each microphone mounts a high quality capsule and its frequency response has been optimized according to the drum instrument to mike (snare, tom, bass drum, cymbals). DSKIT-7 includes supports for various types of microphone and comes with a flight case for easy transport.

- Advanced electroacoustic characteristic drum microphone set
- Bass drum microphone-full low frequency response for strong and dynamical bass effect pick up
- Snare drum microphone-well designed low and frequency, ideal for snare and tom tom drum
- Condenser microphone with wide frequency response and high frequency resolution for optimal recording of cymbals and hi-hat
- Microphones with rugged body construction
- Rugged Flight Case
- Comes with 1 bass drum mic (BDM-30) , 4 tom/snare mics (TTM-30) , 2 cymbal condenser mics (CM-1000) with windscreen, 4 mic stand holders , 5 drumset mic holders
- Ideal for drums (Bass Drum, Snare Drum, Tom Drum, Cymbals) in live performances and studio recording applications

- For technical specification of each microphone model please refer to the related datasheet
- Dimensions (mm): 420x320x100 - Net Weight : Kg 6

CODE	MSRP EUR	MSRP GBP
E810E	€239,75	£220.09



TA-8280S - Snare Drum Dynamic Microphone

SOUNDSATION TA8280 is a microphone designed to mike snare drums. Tailored frequency response make this microphone the most trustable solution the for drummers playing every rhythmic style assuring the player and the sound engineer a distinct and clear sound reproduction.

- Extremely high grade capsule
- Tailored frequency response for snare drum miking
- High volume level without distortion
- Elegant and durable titanium gold finishing
- Rugged metal construction
- Application: drum snare drums and other percussions of similar nature

- Transducer Principle: Dynamic
- Directivity Characteristic: Cardioid
- Frequency Response: 80Hz-16kHz
- Sensitivity: -52dB±3dB (0dB=1V/Pa at 1kHz)
- Output Impedance: 250Ω±30% (at 1kHz)

CODE	MSRP EUR	MSRP GBP
L441L	€38,56	£35.40





VOXTAKER 192 PRO
PREMIUM QUALITY 192 KHZ/16BIT USB STUDIO MICROPHONE

WWW.SOUNDSATIONMUSIC.COM

BDM-30 - Dynamic Bass Drum Microphone

BDM-30 is a Bass drum microphone with full low frequency response for strong and dynamical bass effect pick up.

- Ideal for Bass Drum in live performances and studio recording applications.
- High Quality Head-grille microphone.
- High Sensitivity and Low Self-Noise.
- Satin Black Color.
- Rugged Body construction.

- Transducer Principle: Dynamic
- Directivity Characteristic: Cardioid
- Frequency Response: 20Hz – 16kHz
- Sensitivity: -69dB ± 3db
- Output Impedance: 150 Ohm±30%
- Microphone Size (Ø ; Length): 52 mm ; 109 mm
- Microphone Weight: 288 g

CODE	MSRP EUR	MSRP GBP
E811E	€47,52	£43.62



TTM-30 - Dynamic Drum Instruments Microphone

TTM-30 Microphone is well designed for low and mid frequencies. It is ideal for snare drums and tom drums.

- Ideal for Snare drums and Tom drums in live performances and studio recording applications.
- High Quality Head-grille microphone.
- High Sensitivity and Low Self-Noise.
- Satin Black Color.
- Rugged Body construction.

- Transducer Principle: Dynamic
- Directivity Characteristic: Cardioid
- Frequency Response: 60Hz – 18kHz
- Sensitivity: -53dB ± 3db
- Output Impedance: 500 Ohm±30%
- Microphone Size (Ø ; Length): 38mm ; 99 mm
- Microphone Weight: 192 g

CODE	MSRP EUR	MSRP GBP
E812E	€32,14	£29.50



CM-1000 - Condenser Microphone

CM-1000 is a professional condenser microphone with wide frequency response and high frequency resolution. It is ideal for cymbals (Hi-Hat, Ride, Crash, Etc.) and requires Phantom Power of 9V to 52V.

- Ideal for cymbals in live performances and studio recording applications.
- High Quality Head-grille microphone.
- High Sensitivity and Low Self-Noise.
- Satin Black Color
- Rugged Body construction

- Transducer Principle: Condenser
- Directivity Characteristic: Cardioid
- Frequency Response: 20Hz – 20kHz
- Sensitivity: -38dB ± 3db
- Load impedance: >= 1000 Ohm
- Output Impedance: <= 100 Ohm
- Self-Noise: 25dB A
- Max Input SPL: 135dB (at 1kHz <=1% T.H.D.)
- Phantom Power: 9V ÷ 52V
- Microphone Size (Ø ; Length): 20 mm ; 129 mm
- Microphone Weight: 107 g

CODE	MSRP EUR	MSRP GBP
E813E	€40,77	£37.43



Voice Mic

TG100 - Desktop Gooseneck Microphone set

SOUNDSATION TG100 is a desktop gooseneck microphone is a professional microphone designed for applications such as large-scale conferences, public addresses, outdoor speeches etc. It adopts a back electret condenser cartridge, which delivers bright and clear sound. This uni-directional microphone featuring high sensitivity and low self-noise can operate by battery power or via phantom power received from an external device like a mixer. Its flexible gooseneck can be adjusted smoothly and quietly to fit any needs and situations and a red LED conveniently mark the on-off state. The zinc base of the microphone has been designed with focus on stability and duration over time.

- Back-electret capsule with hyper-cardioid directivity for max isolation of source voice from ambience
- High sensitivity and wide frequency range
- LED ring power indicator
- Flexible positioning
- Powered by battery or Phantom Power
- Application: conference, broadcasting, public address, communication, home recording.
- Comes with base, cable, windscreen, 2 1.5 Volt AA batteries

- Transducer: Back Electret Condenser
- Polar Pattern: Uni-directional
- Frequency Response: 100Hz-13kHz
- Sensitivity: -38dB±3dB(0dB=1V/Pa at 1kHz)
- Output Impedance: 2000±30%(at 1kHz)
- Load impedance : 1000 Ohm
- Operating Voltage: Phantom Power 9-52V or 3V Battery
- Battery Type: AA,1.5
- Cable : XLR F to XLR M (6 meter)

CODE	MSRP EUR	MSRP GBP
M313M	€87,35	£80.19



TG-100-ver2 - Desktop Microphones base for SOUNDSATION microphones

Desktop base for SOUNDSATION gooseneck microphones powered with Phantom Power 4-52V. The base can be also used as power supplier for any microphone accepting 3V power voltage.



CODE	MSRP EUR	MSRP GBP
M317M	€49,99	£45.89

Voice Mic

MS189 - Desktop Gooseneck Microphone set

SOUNDSATION MS189 is a desktop gooseneck microphone is a professional microphone designed for applications such as large-scale conferences, public addresses, outdoor speeches etc. It adopts a back electret condenser cartridge, which delivers bright and clear sound. This uni-directional microphone featuring high sensitivity and low self-noise can operate by battery power or via phantom power received from an external device like a mixer. Its flexible gooseneck can be adjusted smoothly and quietly to fit any needs and situations and a red LED conveniently mark the on-off state.

- Back-electret capsule with hyper-cardioid directivity for max isolation of source voice from ambience
- High sensitivity and wide frequency range
- LED ring power indicator
- Flexible positioning
- Powered by battery or Phantom Power
- Application: conference, broadcasting, public address, communication, home recording.
- Comes with base, cable, windscreen, 2 1.5 Volt batteries

- Transducer: Back Electret Condenser
- Polar Pattern: Uni-directional
- Frequency Response: 100Hz-16kHz
- Sensitivity: -37dB±3dB(0dB=1V/Pa at 1kHz)
- Output Impedance: 1000±30%(at 1kHz)
- Load impedance : 1000 Ohm
- Operating Voltage: Phantom Power 9-52V or 3V Battery
- Battery Type: AAA,1.5
- Cable : XLR F to XLR M (6 meter)

CODE	MSRP EUR	MSRP GBP
N424N	€63,22	£58.04



SH-550

- Dual elastic bands for isolation
- Adapter with angle adjustment with 5/8 inch thread
- Installable on any microphone stand
- Metal construction material
- Black finish

CODE	MSRP EUR	MSRP GBP
L845L	€44,88	£41.20



SH-250

- Suitable for microphones with a diameter of 42-48mm
- Clamp interior is lined with cloth to protect the microphone
- Dual elastic bands for isolation
- Die-cast steel adapter with 5/8 inch threads with angle adjustment
- Installable on any microphone stand
- Metal construction material
- Satin black finish

CODE	MSRP EUR	MSRP GBP
L844L	€12,62	£11.59



HM500 - Overhead condenser microphone

SOUNDSATION HM500 is an installation professional condenser microphone optimal for use in applications where it is necessary to capture sound sources differently from conventional front position of the microphone.

- Tailored frequency response for rich, clear and sensitive sound reproduction
- Cardioid directivity characteristic for eliminating unwanted noise
- Spring-mounted design for flexible positioning and installation
- Application: Theatre, TV filming studio, conference sound reinforcement

- Transducer Principle: Back Electret Condenser
- Directivity Characteristic: Cardioid
- Frequency Response: 50Hz-16kHz
- Sensitivity: -37dB±3dB (0dB=1V/Pa at 1kHz)
- Output Impedance: 2000±30% (at 1kHz)
- Power Requirements: 9-52V DC Phantom Power

CODE	MSRP EUR	MSRP GBP
M470M	€35,42	£32.52



Shockmounts

SH400

- no more vibrations caused by the mic holding system
- compatible with all cylindrical shape mics with 0,83" body diameter
- recommended for SOUNDSATION microphones SGC-100 / SGC-120/ PCM-5400/PCM-5100/CM-60/CM-61/CM-62

CODE	MSRP EUR	MSRP GBP
N749N	€15,20	£13.95



SH-50

- Suitable for microphones of which bottom screw size is M22X1
- Made of metal for great strength and durability
- Fits most microphone stand holder.

CODE	MSRP EUR	MSRP GBP
L843L	€6,41	£5.88



Antipop

SM82 - Universal Microphone suspension system with integrated POP filter

SM82 is a microphone suspension system for pro studio recording. It allows to mount in suspension mode the microphone firmly and safely, thus eliminating any vibration shocks. It supports any kind of microphone in the diameter range 22 mm - 52 mm and it is suitable for all cylindrical shape condenser microphone and studio mic large diaphragm. The system integrate a dual-membrane POP Filter that allow to move the position of the microphone without any alteration of the recording output.

- Eliminates risks of vibrations in studio recording
- Suitable for all microphones with diameter range 22-55 mm
- Dual Membrane POP Filter Kit



CODE	MSRP EUR	MSRP GBP
1519I	€61,10	£56.09

PS1 - studio microphone pop screen

PS1 is a pop filter used for reducing wind noise during close vocal reproduction in studio apps. You can mount it by clipping to your mic stand. Universal clip mount system for all kind of mic stands.

- Isolate microphone from moisture
- Universal clipping mount for every mic stand



CODE	MSRP EUR	MSRP GBP
M292M	€16,44	£15.09

MCV-120 - 120 pieces pack of disposable microphone covers

The disposable microphone covers are made of TNT and are suitable for both wired microphones and wireless microphones. These covers are equipped with an elastic band which guarantees their stability when applied to the microphone. They are also very useful for windproofing and hygienic protection

- Made in TNT with elastic band and suitable for most wire microphones and wireless microphones
- The covers protect the microphones from dust and other external agents, have a windproof and anti-pop action and are essential for health and hygiene
- The covers can be used in recording rooms, conference rooms, karaoke, hotels, singing rehearsals and much more
- The package contains 120 covers made with the colors red, yellow and black



CODE	MSRP EUR	MSRP GBP
L860L	€7,09	£6.51

Windscreens

W60

- Camera Shotgun microphone Windscreen
- Inside diameter: 1.5 cm
- Length: 12 cm



CODE	MSRP EUR	MSRP GBP
1511I	€2,81	£2.58

W-60H

- 5 pcs set of Headset microphone Windscreen
- Inside diameter: 1
- Length: 2,5 cm



CODE	MSRP EUR	MSRP GBP
M509M	€0,94	£0.86

W-50

- 3 pcs Set of Pencil microphone Windscreen
- Inside diameter: 2
- Length: 5 cm



CODE	MSRP EUR	MSRP GBP
M326M	€2,11	£1.94

W-40-C

- Set of 5 pcs dynamic spherical head microphone Windscreen
- Inside diameter: 5 cm
- Length: 7 cm



CODE	MSRP EUR	MSRP GBP
M990M	€3,68	£3.38

SC-01

- Spherical Microphone grille for 58 style microphones
- Replacement metal wiremesh grille basket to fit the classic 58 type microphone
- Suitable for original 58 type mics and replicas



CODE	MSRP EUR	MSRP GBP
M785M	€5,35	£4.91

Windscreens

W-40-B

- 5 pcs bag of Dynamic spherical head microphone Windscreens
- Inside diameter: 4 cm
- Length: 7 cm
- Comes in 5 pcs set



CODE	MSRP EUR	MSRP GBP
1541I	€2,84	£2.61

W-10

- Studio Recording microphone Windscreen
- Inside diameter: 5 cm
- Length: 10 cm



CODE	MSRP EUR	MSRP GBP
M296M	€3,01	£2.76

W568

- Shotgun microphone Windscreen
- Inside diameter: 2
- Length: 12 cm



CODE	MSRP EUR	MSRP GBP
M297M	€3,41	£3.13

W-20

- Set of 5 pcs Gooseneck Microphone Windscreen
- Inside diameter: 10mm
- Length: 45mm



CODE	MSRP EUR	MSRP GBP
M325M	€1,24	£1.14

W70-H

- Inside diameter: 4 mm
- Length: 2 cm
- Comes in 5 pcs set



CODE	MSRP EUR	MSRP GBP
J616J	€3,43	£3.15

Acoustic widescreen

SH-1000 - Anti-Reflection/Noise Filter Screen for Microphone

Precisely engineer the detail and clarity of your recordings with SOUNDSATION's SH-1000 Microphone isolation shield. The SOUNDSATION SH-1000 isolating microphone screen allows you to make your own recordings with clarity and precision in the details. The high density acoustic foam layer allows the microphone to "breathe" while dampening surrounding noise and limiting echoes and reflections. This creates cleaner, more focused audio. Two outer panels can easily be folded inward to create a tighter isolation chamber for detailed audio recording. The screen can be easily mounted on a microphone stand or on its optional table base. Its lightweight aluminium frame and foldable design ensure that the isolation shield is portable and easy to transport.

- Aluminum outer shell and high-density acoustic foam inner shell.
- Two curved folding panels for easy transport
- It can be installed both on a microphone stand and on its optional table base.

- Screen Dimension (WxH): 420 x 310 mm
- Weight: 1,1Kg



CODE	MSRP EUR	MSRP GBP
L841L	€92,16	£84.60

BSH-1000 - Table base for SH-1000 Anti-Reflection/Noise Filter Screen

The SOUNDSATION BSH-1000 table base was designed for the SOUNDSATION SH-1000 screen. Ensures maximum screen stability after mounting. This base is very useful especially when the BSH-1000 screen is used in radio studios and for home recording.

- Solid and sturdy tabletop stand base for SH-1000 screen
- Stand prepared for mounting the screen included.

- Weight: 2 Kg



CODE	MSRP EUR	MSRP GBP
L842L	€8,01	£7.35

PPS-1 - Phantom Power Supply for Condenser Microphones

+48V Phantom Power Supply for Condenser Microphones, with 3-Pin XLR Input and 3-Pin XLR Output connectors. Power adapter included.

- +48V Phantom Power
- 3-Pin XLR Input and Output
- Power On/Off switch with LED
- 18Vac Power Adapter included

CODE	MSRP EUR	MSRP GBP
E573E	€25,62	£23.52



UVC-BOX - 6 LED UVC Sterilizing Box



SOUNDSATION UVC-BOX uses UVC LED lights to eliminate most of the bacteria/viruses that may be present on commonly used objects such as microphones, headphones, etc. LED UVC light kills bacteria/viruses by destroying its DNA or RNA, to stop them from reproduction and regeneration physically. This product is extremely practical, portable and with a high disinfection rate of up to 99.99%. UVC-BOX is safe, free of radiation and helps to avoid contact transmission of viruses / bacteria.

- High disinfection rate up to 99.99%
- Disinfection time of about 3 minutes for items placed in the box
- Easy to use
- Power adapter and USB power cable included in the package
- Good size for inserting objects and grey finish

- UVC LEDs: 6
- UVC LED Life: 10000 Hours
- Wavelength: 265nm
- Input Voltage: 5V
- Output Voltage: 8,1V
- Power: 4.6W
- Current: 760mA
- Power Input Connector: USB (C-type)
- Power supplier: Included
- USB power cable: Included
- Working Temperature: 0 ~ 40°C
- Dimensions(WxDxH): 305x210x165 mm
- Weight: 0,74Kg (power supply and USB cable excluded)

CODE	MSRP EUR	MSRP GBP
L848L	€67,17	£61.66



Clamps & Adapter

DH-90 - Drumset microphone holder

DH-90 is a microphone holder especially suitable for drum recording and reinforcement applications, featuring vibration noise absorption

CODE	MSRP EUR	MSRP GBP
M351M	€8,32	£7.64

**CH-58 - Cylindrical Microphone holder**

CH58 is a clamp for holding most cylindrical bodied microphones. It can hold all kind of microphones having a diameter between 20-25mm .

CODE	MSRP EUR	MSRP GBP
M524M	€3,81	£3.50

**MH-4 - Microphone holder in ABS for medium sized microphones**

- Microphone holder suited for most medium sized dynamic microphones
- Built in sturdy ABS material
- Angle adjustment
- Including 5/8" thread to attach on standard microphone stands

CODE	MSRP EUR	MSRP GBP
S015S	€2,20	£2.02

**SMCH-1 - Universal clamp style microphone holder**

- Clamp style universal design
- Suited for most microphones
- Built in sturdy ABS
- Angle adjustment
- Including 5/8" thread to attach on standard microphone stand

CODE	MSRP EUR	MSRP GBP
S803S	€2,37	£2.18

**MH-2 - Microphone holder in ABS for medium sized microphones**

- Microphone holder suited for most medium sized dynamic microphones
- Built in sturdy ABS material
- Angle adjustment
- Including 5/8" thread to attach on standard microphone stands

CODE	MSRP EUR	MSRP GBP
M991M	€2,15	£1.97

**MH-WM**

- Microphone holder suited for most handheld wireless microphones and large-sized dynamic microphones
- Built in sturdy ABS material
- Adjustable angle
- Including the 5/8" thread to mount on standard microphone stands

CODE	MSRP EUR	MSRP GBP
E582E	€1,71	£1.57

**ST-1000 - Mic Stand thread adapter 3/8 inch to 5/8**

Thread adapter to connect microphone holder with standard microphone stand.

CODE	MSRP EUR	MSRP GBP
M695M	€1,50	£1.38

**TH-31 - Tie Clip Microphone holder**

A dedicated clip to hold lavaliere type microphones on clothes or any other kind of thin surface .

CODE	MSRP EUR	MSRP GBP
M353M	€1,30	£1.19

**GKXLR-16-BK - Gooseneck for microphone stand with XLR connectors**

- Gooseneck for microphone base or panel mounted XLR connectors
- Male XLR and female XLR connectors
- Internally wired
- Length: 40 cm
- Built in steel
- Black finish

CODE	MSRP EUR	MSRP GBP
N783N	€12,92	£11.86

**GKXT-16-BK - Gooseneck for microphone stand**

- Gooseneck for microphone stand
- 5/8" male and 5/8" female threads
- Length: 30 cm
- Built in steel
- Black finish

CODE	MSRP EUR	MSRP GBP
N784N	€5,65	£5.19



Gooseneck



HEADPHONES

MH-80U - Multimedia USB Stereo Headphone MH-80U

SOUNDSATION MH-80U is a Plug & Play multimedia headphone designed to be used in many applications such as work environments that require its use in combination with a PC, smart working, listening to your favorite music and gaming, also due to its compatibility with PS4® and XBOX®. The microphone has noise canceling in order to get a cleaner sound and with less interference from outside noise. The cable includes some buttons for adjusting the microphone volume and other functions (Mute ON / OFF). The volume adjustment of the headphones is obtained by means of a small wheel positioned on the left ear pad. The stereo sound of this headset is of high quality and offers deep bass and excellent sharpness in the high frequencies. The lightness and the ear pads covered with a soft leatherette padding for a comfortable fit make it possible to use the headphone even for a long time. The headphone is equipped with a 2 meter long cable in order to provide greater mobility and comfort.

- Headphone with Plug & Play USB connection
- Compatibility with PC, MAC, PS4® and XBOX®
- Noise-canceling microphone
- High-quality stereo sound with deep bass and excellent high-frequency clarity
- Push-button panel for microphone volume adjustment and other functions (Mute ON/OFF) included in the cable
- Headphone volume adjustment using a small wheel positioned behind the left ear pad
- Ear pads and upper part of the headphones covered with a soft leatherette padding for a comfortable fit.
- Lightweight headphone with elegant design
- 2 meter long cable with USB connection



- Driver diameter: 40mm
- Impedance: 32ohm ±15%
- Sensitivity: 115dB ±3dB
- Frequency range: 20Hz-20KHz
- Microphone dimension: f6,0*5,0
- Microphone sensitivity: -55dB ±2dB
- Directivity: Noise Cancelling
- Rated power: 25 mw
- Max input power: 40 mw
- Headphone interface: USB
- Cable Length: 2.0m ±10%
- Dimension (WxDxH): 210 x 100 x 200 mm- Weight: 0,4 Kg

CODE	MSRP EUR	MSRP GBP
L862L	€23,76	£21.81

MH-70BT - Adjustable Stereo Headphones with "BT Audio Streaming" function

The MH-70BT headphones, thanks to the integrated "BT Audio Streaming" function, are ideal both for listening to music and for managing telephone calls from remote devices such as tablets and smartphones. The MH-70BT headphones are equipped with an integrated microphone and buttons with which you can accept or end a phone call. The buttons can also be used to adjust the volume of a song or to switch to listening to another song. The earpads, made of soft material, and the adjustability of the headphones ensure optimal comfort and fit respectively. The integrated "BT Audio Streaming" function allows you to wirelessly use the MH-70BT headphones by pairing with remote devices such as smartphones or tablets. Using the supplied cable and jack adapter, the headphones can be connected to any audio device that has a dedicated headphone output (PHONES). Quality, versatility, design and excellent quality / price ratio are the characteristics that make the MH-70BT headphones a product that meets all needs.

- Excellent performance in many music applications and in the management of telephone calls. Long lasting performance, maximum comfort and durability.
- Designed with "BT Audio Streaming" Function for wireless use.
- Integrated Microphone
- Integrated buttons for controlling telephone calls and for listening to your favorite music.
- Good quality sound reproduction
- Adjustable headband for maximum comfort
- Long, tangle-resistant cable supplied
- Stereo 6.35mm (1/4 ") jack adapter supplied
- Ideal for a wide variety of environments & applications

- Driver Diameter: 40mm
- Impedance: 32 Ohm ±15%
- Frequency Response: 50hz-20khz
- Sensitivity (S.PL): 110dB
- Supplied Cable: 180 Cm, Tangle Resistant
- "BT Audio Streaming" Function: Yes (For wireless use)
- Integrated Microphone: Yes
- Integrated Buttons: 4 (for managing telephone calls and listening to songs from remote devices)
- Plug: 3.5mm Jack and 6.3mm (1/4") Adaptor
- Weight: 0.26 kg (with cable & adapter)



CODE	MSRP EUR	MSRP GBP
L858L	€20,64	£18.95

MH-50 - Wired Stereo headphone

The MH-50 is a light and comfortable dynamic headphone with round-shaped earpads that allow perfect adherence, excellent acoustic insulation for an immersive sound and excellent attenuation of the surrounding noise. The MH-50 headphone is equipped with a single 180cm cable with a 35mm mini-jack connector for connection to smartphones, tablets, etc. The MH-50 headset is supplied with a 6.35 mm (1/4 ") stereo jack adapter so as to make it ideal for a wide variety of environments and applications.

- Excellent and long lasting performance in many musical applications with excellent comfort.
- Good quality sound reproduction
- Adjustable headband for maximum comfort
- Long, tangle-resistant cable
- Stereo 6.35mm (1/4 ") jack adapter supplied
- Ideal for a wide variety of environments & applications: DJ, Musicians, Etc.

- Driver Diameter: 40 mm
- Impedance: 32 Ohm ±15%
- Frequency Response: 50hz-20khz
- Sensitivity (S.PL): 110dB
- Rated Power: 25mW
- Max Input Power: 50mW
- Cord Length: 180 Cm, Tangle Resistant
- Plug: 3.5mm Jack and 6.3mm (1/4") Adapter
- Weight: 0.26 kg (with cable & adapter)



CODE	MSRP EUR	MSRP GBP
L859L	€14,74	£13.53

MH-500 PRO - High-Grade Closed-Back Studio Headphones

Lightweight yet robust construction to achieve maximum comfort and high-attenuation of background noise. The MH-500 Pro is a dynamic professional grade stereo headphone for any monitoring purpose, even for long-lasting sessions. The 50 mm high-definition membrane offers wide dynamic range and clear sound to detect any details. The result is a professional tool extremely useful to musicians, sound engineers and audio editing technicians who need to explore all the sound content without adding or cutting anything from the original sound.

- High ambient noise attenuation
- Accurate and linear sound reproduction
- Unique professional design, lightweight and durable
- Auto-adjusting headband with superior comfort for extended use
- Closed-back design to achieve best monitoring
- 50mm membrane high-definition driver with wide dynamic range
- Low-impedance, high-sensitivity, compatible with all headphone outputs
- Low-noise oxygen free cabling, single left side exit
- Extensible (1.5m to 4m) and detachable coil cable with gold-plated 3.5mm stereo Jack
- Durable screw-on gold-plated 6.35mm (1/4") stereo Jack adaptor
- Suitable for all recording studio, DJ and monitoring occasions

- Loudspeaker Diameter: 50mm
- Impedance: 32 ohm
- Sensitivity: 98 dB ±3dB
- Frequency Response: 10Hz – 35kHz
- Maximum Power: 1200mW
- Cable Length: 1.5m - 4m (extensible coil cable)
- Plug: 3.5mm Stereo Jack, 1.4" (6.35mm) screw-on adaptor
- Size (WxDxH): 145 x 105 x 220 (min.) / 250 (max.) mm
- Weight: 0.37kg (with cable & adapter)

CODE	MSRP EUR	MSRP GBP
J025J	€55,12	£50.60



MH-100 - Professional Over-Ear Monitor Headphones

Lightweight, comfortable and robust professional headphones designed even for long periods. The closed-back design and the high sound pressure handling make the MH-100 suitable for DJs, audio equipment testing, professional monitoring, cameramen, allowing an immersive sound and a high attenuation of background noise.

- Maximum Performance in both DJ and Studio applications
- Long-lasting performance, maximum comfort, and durability
- High-quality sound reproduction with warm bass and fresh treble
- Adjustable headband for maximum comfort
- Long, tangle-resistant cable
- Ideal for a wide variety of environments & applications: DJ, Audiophile, Musicians, Studio recording

- Type: Stereo Over-Ear Design
- Driver Diameter: 53 mm
- Impedance: 60 Ohm
- Body Construction: Faux Leather-wrapped Metal Headband
- Frequency Response: 15Hz-32KHz
- Sensitivity (S.PL): 94dB ± 3dB
- Cord Length: 3 Meter, Tangle Resistant
- Plug (Gold Plated): 3.5mm Jack and 6.3mm (1/4") Adaptor
- Size (WxDxH): 195 x 100 x 200 mm
- Weight: 0.305kg (with cable & adapter)



CODE	MSRP EUR	MSRP GBP
J024J	€35,41	£32.51



HM-770U - Universal headset for wireless microphone systems

- Unidirectional quality capsule for excellent vocal transmission
- Minimal and light design to wear comfortably
- Adjustable headband
- light beige
- Ic comes with mini-XLR cable terminal and adaptors to make it compatible for use with most popular wireless systems (SENNHEISER, AKG, SHURE, TAKSTAR)
- Other supplied accessories: windscreen



- Transducer: back electret condenser
- Polarity: Unidirectional
- Frequency response: 20Hz-20Khz
- Sensitivity: -45dB
- Poer requirements: DC2V, 0.5mA
- Impedance: 2.2K 30%
- Cable: 1.5mm diameter, 1.2 meter lenght (mini-XLR 3 pin connector M)
- Bodipack adaptors: 4 pin mini TA4F, minijack 3,5" mono

CODE	MSRP EUR	MSRP GBP
N490N	€27,01	£24.80

HM-700 - Condenser Headset Microphone

- Overhead wear style
- Cardioid directivity characteristic for eliminating unwanted noise
- Light and comfortable wearing



- Transducer Principle: Back Electret Condenser
- Directivity Characteristic : Cardioid
- Frequency Response : 50Hz - 16kHz
- Sensitivity : -45dB±3dB (0dB=1V/Pa at 1 kHz)
- Output Impedance: 1000 Ohm ± 30% (at 1kHz)
- Max Operating Voltage : 10V
- Power Requirements : 1.5 V

CODE	MSRP EUR	MSRP GBP
M290M	€8,72	£8.00

EP2225 -In-ear headphones

- in-ear design for maximum noise isolation
- punchy bass, natural mids and clear highs
- supplied with three pairs of ear pads in different sizes for optimal fit
- optimal for CD-players, MP3, monitoring apps

- Transducer Principle: Dynamic
- Driver Diameter : Ø9.2mm
- Impedance: 16Ω
- Sensitivity: 100dB±3dB (at 1kHz)
- Frequency Response: 20Hz-20kHz
- Cable: Approx. 1.5m
- Plug: Stereo Ø3.5mm

CODE	MSRP EUR	MSRP GBP
N754N	€8,35	£7.67

**POCKET-AMP - 4 channel mini headphone amplifier with power supplier**

Pocket series has been conceived to satisfy musicians and audiophile needs. When more people is called to listen the same source, as in recording sessions, Pocket amp is a simple and effective solution. You can connect up to 4 headphones, each with its independent volume level. An essential tool in an ultra-compact package.

- 4 channel mini headphone amplifier with noiseless premps
- Ultra compact size 110 x 57x 31 mm
- Connect 4 headphones at the same time
- Independent volume control for each channel
- 4 headphone outputs TRS 6,3mm
- Stereo input TRS 6,3 mm
- 12V DC power supplier included

CODE	MSRP EUR	MSRP GBP
I517I	€42,97	£39.45



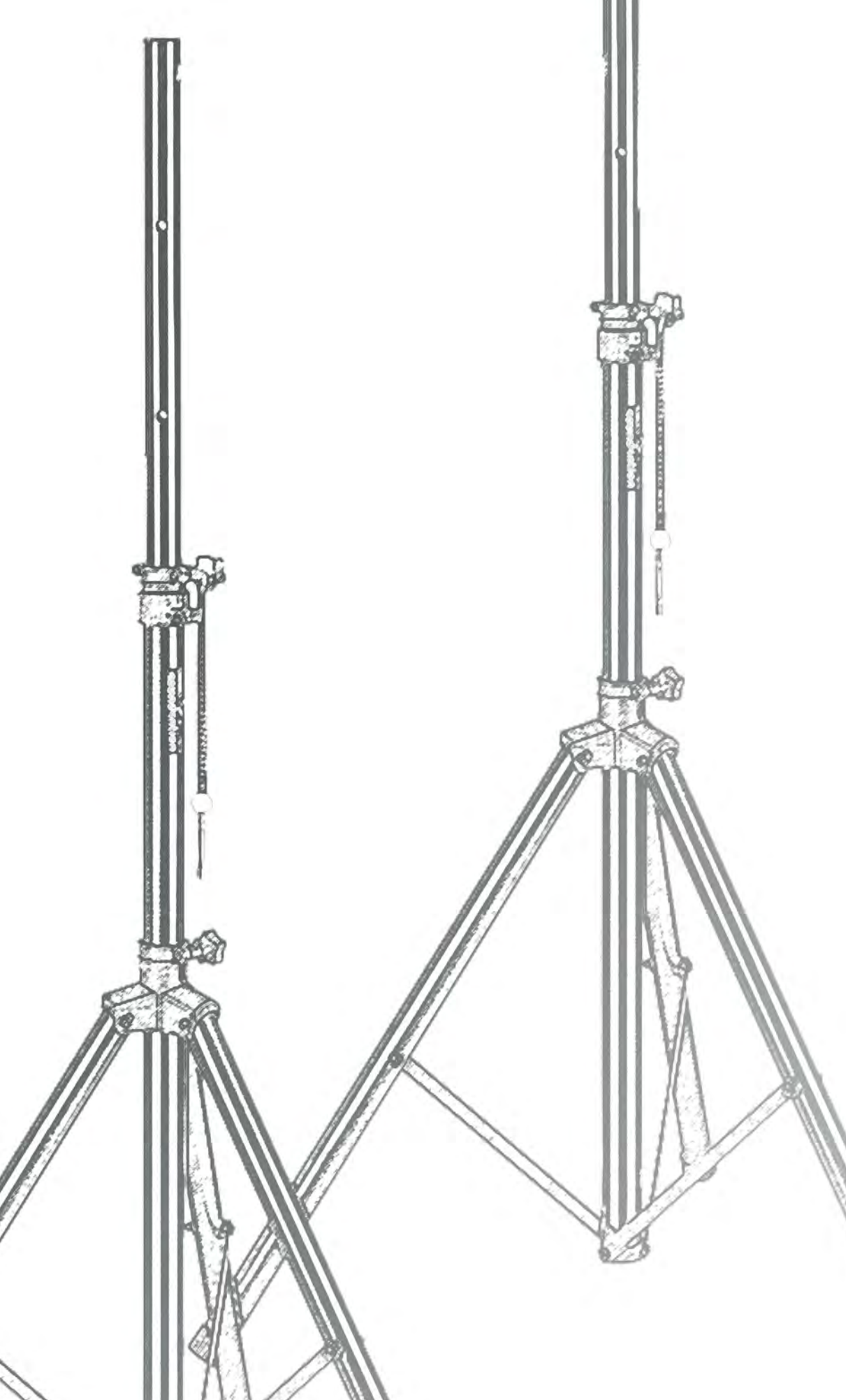

STAGE EQUIPMENT

Conceived for rental companies and musician on the road, Soundsation carriage carts bring a practical and efficient solution to carry your stage equipment. The foldable design allow the cart to be fitted in a small space. Available in different sizes to fit any needs.

TR200 - Foldable equipment carriage cart large size

- 4 wheels equipment carriage cart large size
- Practical and efficient solution to carry your equipment
- Foldable design allows to fit in small space
- Two adjustable handles
- Adjustable base length (from 730 to 1200 mm)
- Folded dimension (LxH): 850x280mm
- Unfolded dimensions (LxWxA): 730-1200x377x770 mm
- Load capacity: 200 Kg
- Weight: 12,8 Kg

CODE	MSRP EUR	MSRP GBP
L897L	€142,86	£131.15



TR100 - Foldable equipment carriage cart medium size

- 4 wheels equipment carriage cart medium size
- Practical and efficient solution to carry your equipment
- Foldable design allows to fit in small space
- Two adjustable handles
- Adjustable base length (from 580 to 850 mm)
- Folded dimension (LxH): 700x235mm
- Unfolded dimensions (LxWxA): 580-850x377x770 mm
- Load capacity: 100 Kg
- Weight: 8,3 Kg



CODE	MSRP EUR	MSRP GBP
L896L	€107,93	£99.08

TR50-MINI - Foldable equipment carriage cart 2 wheels

- 2 wheels equipment carriage cart
- Practical and efficient solution to carry your equipment
- Foldable design allows to fit in small space
- Adjustable handle
- Folded dimension (LxH): 700x200mm
- Unfolded dimensions (LxWxA): 700x377x752
- Load capacity: 50 Kg
- Weight: 5,7 Kg



CODE	MSRP EUR	MSRP GBP
L895L	€76,28	£70.03

SPST-SET70-BK - Speaker stand kit with carrying bag

Complete and useful kit featuring 2 speaker stands and a carrying bag. The included SSPS-70 stands are built in sturdy steel, with 35mm pole mount and safety pin. Perfect for live situations to carry the speaker stand easily preventing possible damages.

- Kit including 2 pcs SSPS-70-BK and carrying bag
 - Stands made of ultra resistant steel
 - Stands with 35mm pole mount, fitting most speakers
 - Stands are foldable for convenient carrying
 - Stands with metal safety pin
 - Carrying bag with handles
- Stand pole size: 35 mm
 - Load capacity: 40 Kg
 - Height (min-max): 120-180 cm
 - Weight: 5,5 Kg
 - Construction material: steel body, base joint and handles in nylon
 - Finish: painted black
 - Bag material: nylon

CODE	MSRP EUR	MSRP GBP
D795D	€64,11	£58.85



SPST-SET80-BK - Speaker stand kit with carrying bag

Complete and useful kit featuring 2 aluminium speaker stands and a carrying bag. The included SSPS-80 stands are built in lightweight and sturdy aluminium, with 35mm pole mount and safety pin. Perfect for live situations to carry the speaker stand easily preventing possible damages.

- Kit including 2 pcs SSPS-80-BK and carrying bag
 - Stands made of aluminium, lightweight and sturdy
 - Stands with 35mm pole mount, fitting most speakers
 - Stands are foldable for convenient carrying
 - Stands with metal safety pin
 - Carrying bag with handles
- Stand pole size: 35 mm
 - Load capacity: 50 Kg
 - Height (min-max): 125-185 cm
 - Weight: 2,00 Kg
 - Construction material: aluminium body, base joint and handles in nylon
 - Finish: painted black
 - Bag material: nylon

CODE	MSRP EUR	MSRP GBP
N946N	€79,03	£72.55



SPST-SET-AIR-BK - Speaker stand kit Safety air system with carrying bag

Complete and useful kit featuring 2 aluminium speaker stands and a carrying bag. The included stands are built in lightweight and sturdy aluminium and adopt the Safety Air system to avoid sudden drop of the speaker and ensure smooth and safe operations. Perfect for live situations to carry the speaker stand easily preventing possible damages.

- Kit including 2 pcs SSPS-AIR with Safety air system and carrying bag
- Stands made of aluminium with diecast joint, lightweight and sturdy
- "Safety Air System" ensure smooth descending of the speaker for safe operations
- Stands with 35mm pole mount, fitting most speakers
- Stands with metal safety pin
- Carrying bag with handles

- Stand pole size: 35 mm
- Load capacity: 60 Kg
- Height (min-max): 140-220 cm
- Weight: 3,8 Kg each stand (7,8 kg for the whole kit)
- Construction material: aluminium body, diecast base joint and handles in nylon
- Finish: painted black
- Bag material: nylon

CODE	MSRP EUR	MSRP GBP
D816D	€108,24	£99.36



SSP-AIR-BK - Aluminium speaker stand with Safety Air System

SSPSAIR is a speaker stand with 35 mm pole mount. Safety Air System ensure a smooth descending of the speaker in case the pin has been removed, for safe operating. The whole structure is in aluminium, lightweight and sturdy, with reinforced diecast steel base joint. The screw height adjustment system is double secured by a safety pin. It's collapsible, lightweight and easy carrying.

- Alluminium body, lightweight and sturdy
- "Safety Air System" ensure smooth descending of the speaker for safe operations
- Reinforced diecast steel base joint
- 35 mm pole mount
- Screw blocking system with handle
- Metal safety pin system

- 35 mm pole mount, main tube 38 mm
- Load capacity: 60 Kg
- Height (min-max): 140-220cm
- Weight: 3,8 Kg
- Construction material: aluminium
- Finish: painted black

CODE	MSRP EUR	MSRP GBP
N310N	€47,54	£43.64



SSPS-80-BK - Aluminium speaker stand with 35 mm pole mount and nylon base joint

SSPS-80 is a speaker stand with 35 mm pole mount. The whole structure is in aluminium, lightweight and sturdy, with a reinforced nylon base joint. The screw height adjustment system is double secured by a safety pin. Suitable for most speaker models. It's collapsible, lightweight and is easy to carry.

- Lightweight, sturdy and anti corrosion aluminium construction
- Reinforced nylon base joint
- 35 mm pole mount, suitable for most speaker models
- Screw locking system with handle
- Metal safety pin system

- Load capacity: 50 Kg
- Height (min-max): 1250-1850 mm
- Lower main tube diameter: 400 mm
- Weight: 2 Kg
- Construction material: aluminium
- Finish: painted black

CODE	MSRP EUR	MSRP GBP
D712D	€36,15	£33.19



SSPS-70-BK - Speaker stand with 35 mm pole mount and nylon base joint

SSPS-70 is a speaker stand with 35 mm pole mount. The whole structure is in steel, sturdy and resistant, with a reinforced nylon base joint. The screw height adjustment system is double secured by a safety pin. Suitable for most speaker models. It's collapsible, lightweight and is easy to carry.

- Steel sturdy construction
- Reinforced nylon base joint
- 35 mm pole mount, suitable for most speaker models
- Screw locking system with handle
- Metal safety pin system

- Load capacity: 40 Kg
- Height (min-max): 1200-1800 mm
- Lower main tube diameter: 400 mm
- Weight: 2,5 Kg
- Construction material: Steel
- Finish: painted black

CODE	MSRP EUR	MSRP GBP
D796D	€26,85	£24.65



SMON-100 - Studio monitor adjustable stand with foldable base

SMON-100 is an adjustable stand for studio monitors. The foldable base ensure great stability. Isolation is a key point when choosing a monitor stand. For this reason, we included metal spikes and the monitor base has two rubber bands. In this way we can avoid unwanted vibrations. A professional product that will fit every budget.

- Steel stand with foldable base to reduce the size without compromising stability
- Height adjustment with safety pin for safe and correct positioning
- Metal spikes for perfect floor isolation
- Two rubber bands over the plate to isolate the monitor from the stand

- Height (min-max): 69 - 130 cm
- Monitor base dimensions: 230x230 mm
- Base diameter: 500 mm
- Load capacity: 15 Kg
- Weight: 4 Kg

CODE	MSRP EUR	MSRP GBP
L898L	€42,26	£38.79



SSPS-50-BK - Aluminium speaker stand with 25mm pole mount

SSPS-50 speaker stand with 25mm pole mount, suitable for small/medium sized speakers. The whole structure is in alluminium, lightweight and sturdy. Height is adjustable trough a safe screw system. It's collapsible, lightweight and is carrying

- Alluminium body, lightweight and sturdy
- 25mm pole mount
- Screw blocking system with handle

- 25mm pole mount Height (min-max): 100-160cm- Load capacity: 30 Kg Construction material: aluminium Weight: 2 Kg Finish: painted black

CODE	MSRP EUR	MSRP GBP
N082N	€34,62	£31.78



SMON-200 - Adjustable studio monitor stand

TSMON-150 is a height-adjustable metal table stand for studio monitors. Insulation is a fundamental factor in the choice of the support and for this purpose, under the base, there are 4 rubber spacers while, on the surface on which the monitor rests, it has two rubber risers. These measures eliminate unwanted vibrations. TSMON-150 is a professional product with excellent value for money.

- Steel support with triangular base to reduce the footprint without sacrificing stability
- Steel stand with triangular shaped base to reduce the size without compromising stability
- Conical metal feet to ensure perfect insulation from the ground
- Two rubber bands over the plate to isolate the monitor from the stand

- Height (min-max): 69 - 130 cm
- Dimensions of the monitor support base: 23 x 23 cm
- Ground base dimensions: 45 x 45 x 45 cm

CODE	MSRP EUR	MSRP GBP
D749D	€37,87	£34.76



SUBST100-35 - Subwoofer mount speaker stand

SUBST100 is a speaker stand you can plug on your subwoofer to support your satellite speaker. Built in ultra-rugged steel, it features a safety pin and adjustable height.

- Speaker stand with 35mm pole mount
- Can be used with 35mm subwoofer socket
- Built in rugged steel
- Height adjustment through a screw blocking system with handle
- Metal safety pin system

- Height (min-max): 800-1360 mm
- Load capacity: 50 Kg
- Weight: 1,4 Kg

CODE	MSRP EUR	MSRP GBP
D701D	€11,39	£10.46

WSS-08 - Wall mount speaker stand with inclination adjustment pin

WSS-08 is an essential tool to install speakers in several situations: bars, restaurants, school, conference room, etc. Sturdy and stable, it's built in metal and it comes with 4 wall fixing points in order to guarantee best stability. Speaker can be directed through the horizontal junction, while inclination can be adjusted in 3 different positions.

- Fully built in metal material
- 35mm pole mount
- 4 wall fixing point with included screws
- 180° horizontal adjustment for optimal direction
- Inclination can be adjusted in 3 different positions with safety pin (0°, 19°, 39°)
- Load capacity: 50 Kg

- Horizontal directivity: 180°
- Inclination: from 0° to -29° in 3 positions
- Horizontal distance of fixing holes: 104 mm
- Vertical distance of fixing holes: 160 mm
- Plate dimension (LxH): 120 x 180mm
- Total length: 300 mm
- Pole mount dimensions: (ØxH): 35 x 120 mm



CODE	MSRP EUR	MSRP GBP
N162N	€25,81	£23.69

SSPAD-10 - Speaker stand adaptor from 35mm to 25mm

SSPAD-10 is a useful tool when it comes to use a 35mm speaker stand with a speaker having a 25mm pole mount. Easy to mount, it's built in metal to ensure sturdiness and safe use.

- Built in metal
- To apply over the terminal of 35mm stand
- Compatible with speaker with 25mm pole mount

CODE	MSRP EUR	MSRP GBP
D703D	€5,35	£4.91



SUBST100-M20 - Subwoofer mount speaker stand with M20 thread

SUBST100 is a speaker stand you can plug on your subwoofer to support your satellite speaker. Built in ultra-rugged steel, it features a safety pin and adjustable height. The M20 base thread allows to attach the pole to the subwoofers avoiding unwanted vibrations.

- Speaker stand with 35mm pole mount
- Can be used with M20 subwoofer socket avoiding unwanted vibrations
- Built in rugged steel
- Height adjustment through a screw blocking system with handle
- Metal safety pin system

- Height (min-max): 800-1360 mm
- Load capacity: 50 Kg
- Weight: 1,4 Kg

CODE	MSRP EUR	MSRP GBP
D815D	€14,09	£12.93



WSS-10 - Wall mount black speaker stand with omniball system

WSS-10 is an essential tool to install speakers in several situations: bars, restaurants, school, conference room, etc. Sturdy and stable, it's built in metal and it comes with 4 wall fixing points in order to guarantee maximum stability. Speaker can be directed by 180 degrees in all directions, thanks to the omniball system.

- Fully built in metal material
- Two speaker fixing points
- 4 wall fixing point (screws not included)
- Omniball system for 180° horizontal adjustment in all directions

- Load capacity: 18 Kg
- Directivity: 180° in all directions
- Horizontal distance of wall fixing holes: 79 mm
- Vertical distance of wall fixing holes: 81 mm
- Distance of speaker fixing holes: 60mm +/-6mm
- Wall plate dimension (LxH): 99 x 99 mm
- Speaker plate dimension (LxH): 80 x 40mm
- Total length: 120 mm
- Weight: 0,7 Kg

CODE	MODEL	COLOR	MSRP EUR	MSRP GBP
D865D	WSS-10B	Black	€11,96	£10.98
D866D	WSS-10W	White	€11,96	£10.98



SMICS-200-BK

Microphone boom stand with tripod base and metal joints

- Telescopic arm with distance and angle adjustment
- Quick & Easy clutch style height adjustment mechanism with Zinc handle
- Metal counterweight for perfect balance with heavy microphones
- Base joint material: Metal
- Height(min-max): 110-176 cm
- Boom arm length: 53-91 cm
- Weight: 3,5 Kg
- Black Finish

CODE	MSRP EUR	MSRP GBP
M707M	€37,31	£34.25



SMICS-120-BK

Microphone boom stand with metal tripod base

- Telescopic arm with distance and angle adjustment
- Quick & Easy height clutch adjustment mechanism
- Diecast steel sturdy base
- Base joint material: diecast steel
- Height(min-max): 100-165 cm
- Boom arm length: (min-max): 58-91 cm
- Weight: 2,3 Kg
- Black finish

CODE	MSRP EUR	MSRP GBP
D761D	€33,45	£30.71



SMICS-100-BK

Microphone boom stand with tripod base

- Quick & Easy height clutch adjustment mechanism
- Base joint material: ABS
- Height(min-max): 95-158 cm
- Boom arm length: 75 cm
- Weight: 2 Kg
- Black finish

CODE	MSRP EUR	MSRP GBP
M800M	€26,63	£24.45



SMICS-70-BK

Microphone boom stand with tripod base

- Boom arm with angle e length adjustment
- Quick & Easy height clutch adjustment mechanism
- 35cm legs to ensure optimum stability
- Base joint material: ABS
- Height(min-max): 95-158 cm
- Boom arm length: 75 cm
- Leg length: 35 cm
- Weight: 1,8 Kg
- Black finish

CODE	MSRP EUR	MSRP GBP
D760D	€19,82	£18.19



SMICS-60-BK

Microphone boom stand with tripod base

- Boom arm with angle e length adjustment
- Quick & Easy height clutch adjustment mechanism
- 34 cm legs to ensure optimum stability

CODE	MSRP EUR	MSRP GBP
D966D	€17,60	£16.16



ONE HAND-100-BK

Mic stand featuring ONE HAND system and cast-iron base

- ONE HAND system allowing height adjustment with just one hand
- Round cast-iron base with antivibration ring
- Metal stand
- Finish: Matte Black
- Height: 106-179 cm
- Base diameter: 25 cm
- Weight: 2,3kg

CODE	MSRP EUR	MSRP GBP
I240I	€40,09	£36.80



SMICS-500-BK

Microphone stand with heavy cast-iron base

- 180mm diameter cast-iron base
- Quick & Easy clutch style height adjustment mechanism
- Height (min-max): 88cm-158cm
- Weight: 5 Kg
- Black painted finish

CODE	MSRP EUR	MSRP GBP
M804M	€33,03	£30.32



ONE HAND-200-BK

Mic stand featuring ONE HAND system and tripod base

- ONE HAND system allowing height adjustment with just one hand
- High stability foldable tripod system
- Metal stand
- Finish: Matte Black
- Height: 110-180 cm
- Weight: 2kg

CODE	MSRP EUR	MSRP GBP
I241I	€29,69	£27.26



SMICS-600BK

Desktop microphone stand with cast iron base and telescopic boom

- Cast Iron base, triangular shape
- Telescopic arm with 180 degrees adjustable angle
- Finish: Black
- Boom arm length (min-max): 400-570 mm
- Base dimension: 19 x 19 x 5 cm
- Weight: 3,5 Kg

CODE	MSRP EUR	MSRP GBP
A737A	€30,33	£27.84



SMICS-550-BK

Low level microphone boom stand with tripod base

- Telescopic arm with distance and angle adjustment
- Metal tripod base
- Height: 540 mm
- Arm length (min-max): 58-91 cm
- Weight: 2 Kg
- Black painted finish

CODE	MSRP EUR	MSRP GBP
M803M	€26,63	£24.45



SMXLR-750-BK - Microphone stand with XLR connection

Soundsation SMXLR-750 BK is a straight microphone stand with a quick and easy height adjustment system. The stand is equipped with a 3-pole XLR socket integrated in the upper tube to allow direct connection of a gooseneck type microphone. Using a flexible extension cable with XLR connectors (eg Soundsation GKXLR-16-BK) as an accessory, the stand becomes compatible with all types of microphone. The stand stability is given by a 24.5 cm circular cast iron base on which the XLR connector for connecting the microphone cable is positioned. Installation requires neither microphone clips nor vertical cable mounting. The cast iron base, in addition to containing the connection system with microphone cables, is finished in rubber in the lower part to ensure both stability and sound insulation.

- Finish: Black
- Height Adjustment: From 99 cm to 146 cm
- Base Diameter: 24,5
- Base Weight: 4,4 Kg
- Total Weight: 5,4 Kg
- Package Dimension (WxDxH): 930 x 60 x (min 80 - max 370) mm
- Package Weight: 6,1 Kg

CODE	MSRP EUR	MSRP GBP
L864L	€62,24	£57.14



ST-100M

Professional Table Microphone Arm with Mic Cable

- Table mounting
- For radio, podcaster, home and pro-recording
- 5/8" Thread
- Rotates 360 degrees
- Approx. stand length: 1150mm
- Approx. boom length: 1000mm
- Colour: Black powder-coated
- Screw clamp for table tops up to 53mm
- Cable: 4m balanced cable with 3-Poles XLR-F/XLR-M connector
- Approx. 1.5 kg load



CODE	MSRP EUR	MSRP GBP
E570E	€48,16	£44.21

ST-50M

Professional Table Microphone Arm with Mic Cable

- Table mounting
- For radio, podcaster, home and pro-recording
- 3/8" Thread
- Rotates 360 degrees
- Approx. stand length: 860mm
- Approx. boom length: 800mm
- Colour: Black powder-coated
- Screw clamp for table tops up to 45mm
- Cable: 4m balanced cable with 3-Poles XLR-F/XLR-M connector
- Approx. 1.0 kg load



CODE	MSRP EUR	MSRP GBP
E568E	€25,16	£23.10

ST-TA

Table Surface Adapter for ST-50 & ST-100 series Mic Arms

- Adapter with 3 screws to mount the ST-50 & ST-100 Microphone Arms on table surfaces.
- Die-Cast Aluminum



CODE	MSRP EUR	MSRP GBP
E572E	€5,57	£5.11

ST-105ST-105

Desktop microphone stand

- All purpose desktop microphone stand. This useful tool is able to hold all most common microphones for all applications thanks to the rugged metal construction giving perfect stability. It comes with adapter 3/8" > 5/8" .



CODE	MSRP EUR	MSRP GBP
I909I	€5,68	£5.21

ST-100U

Professional Table Microphone Arm with USB Cable

- Table mounting
- For radio, podcaster, home and pro-recording
- 5/8" Thread
- Rotates 360 degrees
- Approx. stand length: 1150mm
- Approx. boom length: 1000mm
- Colour: Black powder-coated
- Screw clamp for table tops up to 53mm
- Cable: 4m balanced cable with Male Type-B/Type-A connector
- Approx. 1.5 kg load



CODE	MSRP EUR	MSRP GBP
E571E	€47,36	£43.48

ST-50U

Professional Table Microphone Arm with USB Cable

- Table mounting
- For radio, podcaster, home and pro-recording
- 3/8" Thread
- Rotates 360 degrees
- Approx. stand length: 860mm
- Approx. boom length: 800mm
- Colour: Black powder-coated
- Screw clamp for table tops up to 45mm
- Cable: 4m balanced cable with Male Type-B/Type-A connector
- Approx. 1.0 kg load



CODE	MSRP EUR	MSRP GBP
E569E	€24,16	£22.18

MDS-10

Drink holder for microphone stand

- Built in metal
- Quick and safe attachment



CODE	MSRP EUR	MSRP GBP
I243I	€7,20	£6.61

TMONS-PRO - Professional desktop stand for Studio Monitor (pair)

- Sturdy monitor stand in steel
- Adjustable height and incline with graduation
- Rubber top surface for stable grip of the monitor even at a sharp incline
- 4 rubber spacers under the base
- Including optional metal spikes to reduce the contact surface
- Maximum load: 15Kg
- Base Dimensions: 21,5 x 20 cm
- Monitor support plate dimensions: 22 x 18 cm
- Adjustable height: 30-37,5 cm
- Incline angle: -8°/+16°
- Weight: 2,6kg
- Packing dimensions (WxDxH): 255 x 275 x 215 mm
- Packing Weight: 5,67Kg



CODE	MSRP EUR	MSRP GBP
J532J	€106,50	£97.77

TMONS-PRO-CL - Professional stand for Studio Monitor with desktop mounting clamp (pair)

- Sturdy monitor stand in steel
- Adjustable height and incline with graduation
- Attachment clamps with 2 fixing points for maximum stability
- Suitable for desktop up to 50mm thick
- Maximum load: 15Kg
- Monitor support plate dimensions: 22 x 18 cm
- Adjustable height: 30-37,5 cm
- Incline angle: -8°/+16°
- Clamp suitable for desktops of max 50mm thick
- Weight: 2,6kg



CODE	MSRP EUR	MSRP GBP
J533J	€94,57	£86.82

LAPTOP STANDS

SLAP-100 - Adjustable laptop stand

Stable, sturdy, adjustable and built in metal, SLAP-100 is the ideal solution for DJs and musicians who need their laptops at the desired height.

- Built in metal
- Adjustable height: 165 - 255mm
- Finish: black



CODE	MSRP EUR	MSRP GBP
D722D	€19,55	£17.95

TABSTAND-200 - Universal tablet holder with stand attachment clamp

- ABS construction
- Universal stand, compatible with iPad, Mini iPad and most tablets of different sizes
- Tablet holder with adjustable height
- Holder with curved angles to hold the tablet safely
- Turnable joint for landscape or portrait use
- Adjustable clamp to attach with microphone or music stands
- iPAD and Mini iPAD are registered trademark of APPLE inc.
- Tablet holder adjustable length: minimum 150mm maximum 285mm
- Arm length: 100 mm



CODE	MSRP EUR	MSRP GBP
D753D	€17,31	£15.89

SLAP-130 - Table Laptop Stand with adjustable height - length, and table fixing accessories

Ideal for all those musicians, DJs and show operators who need to keep laptops at their fingertips and in a sloped position. Width and height are adjustable. It is also possible to fasten it to the table to increase its stability.

- Width: min 25.5cm - max 30.5cm
- Height: 24cm min - 33cm max
- Max Table Thickness: 4.8mm
- Material: Steel
- Color: Black

CODE	MSRP EUR	MSRP GBP
D968D	€40,78	£37.44



SLAP-120 - Table Laptop Stand with adjustable height - length, and additional intermediate shelf

Ideal for all those musicians, DJs and professionals who need to easily control their laptop, as well as their sound card or other equipment below the laptop. The width and height are adjustable.

- Width: min 25.5cm - max 30.5cm
- Height: 24cm min - 33cm max
- Material: Steel
- Black

CODE	MSRP EUR	MSRP GBP
D967D	€40,78	£37.44



SLAP-220 - Laptop or projector stand with tripod base

SLAP-220 is a very versatile stand, useful on live gigs or practice room to place your equipment at your fingertips. The base inclination can be adjusted, as well as the height. Perfect for laptop, projectors, mixers or effects.

- Multi-use stand for laptop, projectors or other equipment
- Adjustable base angle from 0° to around 80°
- Base Size: 39.5cm x 30cm
- Adjustable Height: from 85cm to 145cm
- Sturdy tripod base with opening diameter between 68 cm and 90 cm, for maximum stability
- Tripod Leg Length: 50cm
- Color: Black
- Weight: 4.3kg

CODE	MSRP EUR	MSRP GBP
D969D	€48,88	£44.87



STAMP-100 - Floor amplifier and cabinet stand

STAMP-100 is a floor stand for your guitar or bass combo amplifier or cabinet with ideal tilted back design to allow hearing your amp properly. Suitable for studio, rehearsal or stage, it's compact and has a foldable design for easy carrying and storage.

- Combo/cabinet floor stand
- Tilt back design for perfect hearing
- Foldable design for easy carrying and storage
- Base size (WxD) 26x43 cm
- Main frame (WxH) 30x30 cm
- Support frame (WxD) 22 x 21 cm

CODE	MSRP EUR	MSRP GBP
J534J	€18,57	£17.05



STAMP-120 - Adjustable amplifier stand

STAMP-120 is a stand for your guitar or bass combo amplifier or cabinet with adjustable incline and tilted back design to allow hearing your amp properly. Suitable for studio, rehearsal or stage.

- Combo/cabinet floor stand
- Tilt back design for perfect hearing
- Adjustable tilt angle
- Rubber rest pads
- Rubber feet
- Base width: 50 cm
- Rest arms width: 30 cm
- Tube diameters: 25 mm
- Height/depth range: from 16/34 cm to 28/23 cm

CODE	MSRP EUR	MSRP GBP
J535J	€25,01	£22.96



STAMP-200 - Adjustable stand for amplifiers up to 50 kg

STAMP-200 is a stand for your guitar or bass combo amplifier or cabinet with adjustable incline and tilted back design to allow hearing your amp properly. Height can be adjusted as well, for easy access. Sturdy construction, it can bear up to 50kg. Suitable for studio, rehearsal or stage,

- Combo/cabinet floor stand
- Tilt back design for perfect hearing
- Adjustable tilt angle
- Adjustable height
- Rubber feet and rest pads
- Ultra robust construction, can bear up to 50 kg
- Rest arms (WxD): 35 x 15 cm
- Tube diameters: 25 mm
- Height range (min-max): 10-70 cm
- Maximum loading: 50 Kg

CODE	MSRP EUR	MSRP GBP
J536J	€48,82	£44.82



SRACK-100 16UW - 16 units 19" rack cabinet with castors

Rack stands SRACK-100 series are built in steel and allow to fit your equipment easily and safely. Available in several sizes, they come with 4 wheels with safety block. Ideal for installations, recording studios and stages.

- 16 units 19" rack cabinet
- Built in rugged steel
- 4 castors with safety block
- Loading capacity: 50 Kg
- Dimensions (LxWxH): 548x438x770 excluding wheels
- Weight: 17,5 Kg



CODE	MSRP EUR	MSRP GBP
L902L	€186,85	£171.53

SRACK-100 8UW - 8 units 19" rack cabinet with castors

Rack stands SRACK-100 series are built in steel and allow to fit your equipment easily and safely. Available in several sizes, they come with 4 wheels with safety block. Ideal for installations, recording studios and stages.

- 8 units 19" rack cabinet
- Built in rugged steel
- 4 castors with safety block
- Loading capacity: 40 Kg
- Dimensions (LxWxH): 548x438x490 excluding wheels
- Weight: 9,8 Kg



CODE	MSRP EUR	MSRP GBP
L900L	€121,86	£111.87

SRACK-100 12UW - 12 units 19" rack cabinet with castors

Rack stands SRACK-100 series are built in steel and allow to fit your equipment easily and safely. Available in several sizes, they come with 4 wheels with safety block. Ideal for installations, recording studios and stages.

- 12 units 19" rack cabinet
- Built in rugged steel
- 4 castors with safety block
- Loading capacity: 50 Kg
- Dimensions (LxWxH): 548x438x668 excluding wheels
- Weight: 11,9 Kg



CODE	MSRP EUR	MSRP GBP
L901L	€154,35	£141.69

CRACK-100 21UW - 21 units 19" rack stand with castors

Rack stands CRACK-100 series are built in steel and allow to fit your equipment easily and safely. Equipment can be racked vertically or horizontally, which is suitable for equipment which need to be controlled frequently like mixers. Coming with 4 wheels with safety block. Ideal for installations, recording studios and stages.

- 21 units 19" rack stand with vertical and horizontal placement
- Built in rugged steel
- 4 castors with safety block
- Adjustable horizontal units
- Dimensions (LxWxH): 560x560x915 excluding wheels
- Weight: 23 Kg



CODE	MSRP EUR	MSRP GBP
L903L	€117,80	£108.14

SRD100-3U LOCK - Rack drawer 19" 3U with lock

A useful accessory to store your tooling and other things. Safety lock with keys.



- 19" Rack drawer
- 3 units
- Equipped with locking and keys
- Height (outer-inner): 133 mm - 117 mm
- Depth (outer): 220 mm

CODE	MSRP EUR	MSRP GBP
L908L	€89,36	£82.03

SRP100-2U - 19" 2 unit blind rack panel

Blind 19" rack panel to close unused space in the rack.



- Blind 19" rack panel
- 2 unit
- Built in metal
- Dimensions (LxH): 482x88.9mm
- Vertical hub spacing: 76.20 mm

CODE	MSRP EUR	MSRP GBP
L910L	€5,45	£5.00

SRP100-3U - 19" 3 unit blind rack panel

Blind 19" rack panel to close unused space in the rack.



- Blind 19" rack panel
- 3 unit
- Built in metal
- Dimensions (LxH): 482x133.4mm
- Vertical hub spacing: 57.15 mm

CODE	MSRP EUR	MSRP GBP
E398E	€6,43	£5.90

SRD100-2U LOCK - Rack drawer 19" 2U with lock

A useful accessory to store your tooling and other things. Safety lock with keys.



- 19" Rack drawer
- 2 units
- Equipped with locking and keys
- width height depth :430 mm - 90mm - 210
- Depth (outer): 221 mm

CODE	MSRP EUR	MSRP GBP
L907L	€56,49	£51.86

SRP100-1U - 19" 1 unit blind rack panel

Blind 19" rack panel to close unused space in the rack.



- Blind 19" rack panel
- 1 unit
- Built in metal
- Dimensions (LxH): 482x44mm
- Vertical hub spacing: 31,75 mm

CODE	MSRP EUR	MSRP GBP
L909L	€3,87	£3.55

SRP100-4U - 19" 4 unit blind rack panel

Blind 19" rack panel to close unused space in the rack.



- Blind 19" rack panel
- 4 unit
- Built in metal
- Dimensions (LxH): 482x177.8mm
- Vertical hub spacing: 101.6 mm

CODE	MSRP EUR	MSRP GBP
E399E	€7,90	£7.25

SRP200-1U - 1 Unit - 19" Rack Panel with ventilation slots

1 Unit - 19" Rack Panel to close unused spaces in a rack and, at the same time, allow good ventilation



- Steel Rack Panel
- 1 Unit
- With Ventilation Slots
- Dimensions (LxH): 482x44.4 mm
- Vertical hub spacing: 31.75 mm

CODE	MSRP EUR	MSRP GBP
E400E	€3,76	£3.45

SRP200-3U - 3 Unit - 19" Rack Panel with ventilation slots

19" Rack Panel to close unused spaces in a rack and, at the same time, allow good ventilation



- Steel Rack Panel
- 3 Units
- With Ventilation Slots
- Dimensions (LxH): 482x133.4 mm
- Vertical hub spacing: 57.15 mm

CODE	MSRP EUR	MSRP GBP
E402E	€6,39	£5.87

SRAD100-1U - 1 Unit - 19" Rack Adapter

19" rack panel to mount devices smaller than 1 rack unit



- Steel Rack Panel
- 1 Unit
- Base with holes to use of a variety of devices smaller than 1 unit.
- Dimensions (LxHxD): 484x44x190 mm - Product weight: 0.3 kg

CODE	MSRP EUR	MSRP GBP
E404E	€16,42	£15.07

SRP200-2U - 2 Units - 19" Rack Panel with ventilation slots

19" Rack Panel to close unused spaces in a rack and, at the same time, allow good ventilation



- Steel Rack Panel
- 2 Units
- With Ventilation Slots
- Dimensions (LxH): 482x88.9 mm
- Vertical hub spacing: 76.20 mm

CODE	MSRP EUR	MSRP GBP
E401E	€4,96	£4.55

SRP200-4U - 4 Unit - 19" Rack Panel with ventilation slots

19" Rack Panel to close unused spaces in a rack and, at the same time, allow good ventilation



- Steel Rack Panel
- 4 Units
- With Ventilation Slots
- Dimensions (LxH): 482x177.8 mm
- Vertical hub spacing: 101.60 mm

CODE	MSRP EUR	MSRP GBP
E403E	€7,68	£7.05

SRAD100-2U - 2 Unit - 19" Rack Adapter

19" rack panel to mount devices smaller than 1 rack unit



- Steel Rack Panel
- 2 Units
- Base with holes to use of a variety of devices smaller than 1 unit.
- Dimensions (LxHxD): 484x88x190 mm - Product weight: 0.4 kg

CODE	MSRP EUR	MSRP GBP
E405E	€16,59	£15.23

CP-200-5CM - 5-Channels Cable Protector

- These rubber protectors are extremely durable, easy to install, and protect many cables type
- Reduce tripping hazards
- Diamond plate slip resistant surface for excellent traction.
- Low angle ramps provide easy access for carts and pedestrians.

- Channels: 5
- Single channel width: 4.2 cm
- Single channel height: 4.2 cm
- Tensile Strength: 15.0 MPA
- Elongation at break: 360%
- Impact elasticity: 31%
- Abrasion Performance: 0.21CM3/1.61KM.
- Hardness: 92A
- Range of Temperature: -5 - +35 Degrees
- Bearing Capacity: 30 TONS
- Materials: Injection Molded 80% Virgin PVC and 20% NBR.
- Dimensions (WxDxH): 90 x 50 x 5,5 Cm - Weight: 8 Kg

CODE	MSRP EUR	MSRP GBP
L850L	€106,81	£98.05

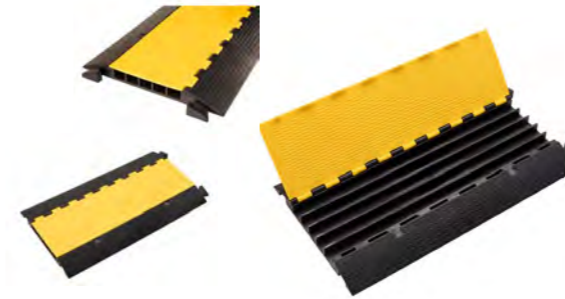

CP-200-3CS - Small 3-channels CABLE Protector

- These rubber protectors are extremely durable, easy to install, and protect many cables type
- Reduce tripping hazards
- Diamond plate slip resistant surface for excellent traction.
- Low angle ramps provide easy access for carts and pedestrians.

- Channels: 3
- Single channel width: 3 cm
- Tensile Strength: 3.0 MPA
- Impact elasticity: 37%
- Abrasion Performance: 0.28CM3/1.61KM.
- Hardness: A85
- Range of Temperature: -45 - +60 Degrees
- Bearing Capacity: 12 TONS
- Materials: Rubber
- Size (WxDxH): 900 x 300 x 45 mm
- Weight: 8,5Kg

CODE	MSRP EUR	MSRP GBP
L856L	€85,56	£78.54

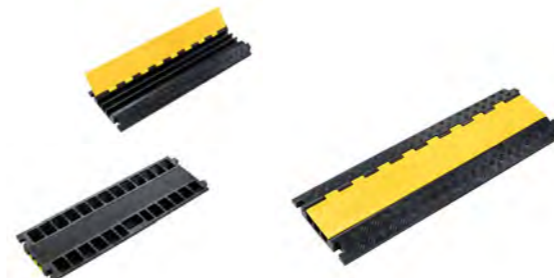

CP-200-3CM - 3-Channels Cable Protector

- These rubber protectors are extremely durable, easy to install, and protect many cables type
- Reduce tripping hazards
- Diamond plate slip resistant surface for excellent traction.
- Low angle ramps provide easy access for carts and pedestrians.

- Channels: 3
- Single channel width: 6.5 cm
- Single channel height: 6.5 cm
- Tensile Strength: 15.0 MPA
- Elongation at break: 360%
- Impact elasticity: 31%
- Abrasion Performance: 0.21CM3/1.61KM.
- Hardness: 92A
- Range of Temperature: -5 - +35 Degrees
- Bearing Capacity: 30 TONS
- Materials: Injection Molded 80% Virgin PVC and 20% NBR.
- Dimensions (WxDxH): 90 x 50 x 7,5 Cm - Weight: 11 Kg

CODE	MSRP EUR	MSRP GBP
L851L	€142,47	£130.79

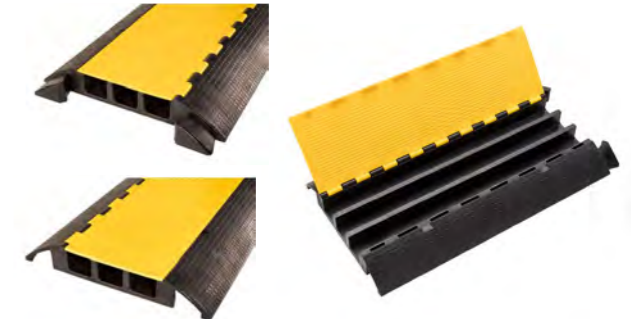

CP-200-2CS - Small 2-Channels Cable Protector

- These rubber protectors are extremely durable, easy to install, and protect many cables type
- Reduce tripping hazards
- Diamond plate slip resistant surface for excellent traction.
- Low angle ramps provide easy access for carts and pedestrians.

- Channels: 2
- Single channel width: 3,2 cm
- Single channel height: 3,2 cm
- Tensile Strength: 15.0 MPA
- Elongation at break: 360%
- Impact elasticity: 31%
- Abrasion Performance: 0.21CM3/1.61KM.
- Hardness: 92A
- Range of Temperature: -5 - +35 Degrees
- Bearing Capacity: 30 TONS
- Materials: Injection Molded 80% Virgin PVC and 20% NBR.
- Dimensions (WxDxH): 90 x 25 x 4,5 Cm - Weight: 5 Kg

CODE	MSRP EUR	MSRP GBP
L852L	€70,65	£64.86

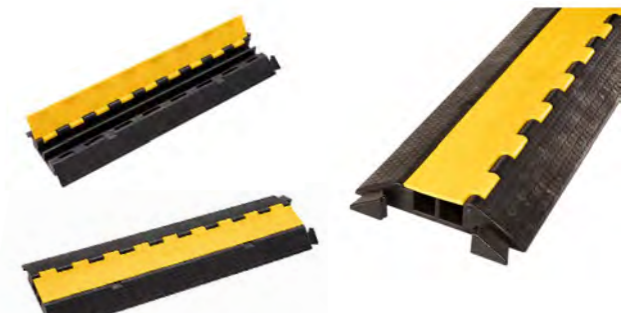

Stage equipment

CABLE PROTECTORS

CC-100-1CS - 1-Channel Small Drop Over Cable Cover

The over 1-channel cable cover CC-100-1CS is a quick and easy solution of cable management. It can protect small cables and cords in home, office, or warehouse.

- Made of polyurethane, light-weight and high strength.
- Unique arched design can enhance the weight loading capacity.
- Surface decorative pattern design, prevent slippery.
- Easy to operate.

- Channels: 1
- Single channel width: 40mm
- Single channel height: 13mm
- Tensile Strength: 15.0 MPA
- Elongation at break: 360%
- Impact elasticity: 31%
- Abrasion Performance: 0.21CM3/1.61KM.
- Hardness: 92A
- Range of Temperature: -5 - +35 Degrees
- Bearing Capacity: 200 Kg
- Materials: Injection Molded 80% Virgin PVC and 20% NBR.
- Dimensions (WxDxH): 900 x 140 x 20 mm - Weight: 1,4 Kg



CODE	MSRP EUR	MSRP GBP
L853L	€26,42	£24.25

CC-100-1CL - 1-Channel Big Drop Over Cable Cover

CC-100-1CL Drop Over Cable cover is a quick and easy solution to cable management. The durable polyurethane is ideal for constant pedestrian foot traffic. A low profile cover provide maximum traction to help lessen the hazards of tripping or slipping. This drop over cable cover is a fast and effective way of protecting small cables and cords in your home, office, or warehouse.

- Protection of cables up to 1" in diameter.
- Easy to setup and break down for storage.
- Molded safety warnings.
- Easy to operate.
- High traction surface tread.
- Great for shopping malls and construction areas with foot traffic.

- Channels: 1
- Single channel width: 105mm
- Single channel height: 25mm
- Tensile Strength: 15.0 MPA
- Elongation at break: 360%
- Impact elasticity: 31%
- Abrasion Performance: 0.21CM3/1.61KM.
- Hardness: 92A
- Range of Temperature: -5 - +35 Degrees
- Bearing Capacity: 2000 Kg
- Materials: Injection Molded 80% Virgin PVC and 20% NBR.
- Dimensions (WxDxH): 900 x 275 x 30 mm - Weight: 3,3 Kg



CODE	MSRP EUR	MSRP GBP
L854L	€55,70	£51.13

CC-100-2CL - 2-Channels Drop Over Cable Cover

CC-100-2CL Drop Over Cable cover is a quick and easy solution to cable management. The durable polyurethane is ideal for constant pedestrian foot traffic. A low profile cover provide maximum traction to help lessen the hazards of tripping or slipping. This drop over cable cover is a fast and effective way of protecting small cables and cords in your home, office, or warehouse.

- Protection of cables up to 1" in diameter.
- Easy to setup and break down for storage.
- Molded safety warnings.
- Easy to operate.
- High traction surface tread.
- Great for shopping malls and construction areas with foot traffic.

- Channels: 2
- Single channel width: 50mm
- Single channel height: 25mm
- Tensile Strength: 15.0 MPA
- Elongation at break: 360%
- Impact elasticity: 31%
- Abrasion Performance: 0.21CM3/1.61KM.
- Hardness: 92A
- Range of Temperature: -5 - +35 Degrees
- Bearing Capacity: 5000 Kg
- Materials: Injection Molded 80% Virgin PVC and 20% NBR.
- Dimensions (WxDxH): 900 x 275 x 30 mm
- Weight: 3,3 Kg



CODE	MSRP EUR	MSRP GBP
L855L	€66,56	£61.10



CABLES

SCBD10-008-20 - 8 inputs 20 meters professional stage box on cable drum

SCBD10-008 is a professional stage box featuring 8 XLR 3 pole female sockets input. Coming on cable drum, it's very convenient to use and carry around. High quality XLR connectors Yongsheng by Neutrik® ensures high quality connections and signal transmission. Independent earth plugs consist an additional construction advantage.

- Input: 8 XLR 3 pole female
- Independent earth plugs
- Hi quality XLR connectors Yongsheng by Neutrik®
- Cable drum to wind /unwind quickly and easy carrying
- Multicore cable lenght: 20 mt



CODE	MSRP EUR	MSRP GBP
D744D	€132,69	£121.81

SCBD10-008-15 - 8 inputs 15 meters professional stage box on cable drum

SCBD10-008 is a professional stage box featuring 8 XLR 3 pole female sockets input. Coming on cable drum, it's very convenient to use and carry around. High quality XLR connectors Yongsheng by Neutrik® ensures high quality connections and signal transmission. Independent earth plugs consist an additional construction advantage.

- Input: 8 XLR 3 pole female
- Independent earth plugs
- Hi quality XLR connectors Yongsheng by Neutrik®
- Cable drum to wind /unwind quickly and easy carrying
- Multicore cable lenght: 15 mt



CODE	MSRP EUR	MSRP GBP
D743D	€120,84	£110.93

SGBX20-1204-20 - Professional aluminium stage box featuring 12 in/ 4 out

SGB20-1604 is a professional stage box with 12 XLR 3 pole panel mount female sockets + 4 XLR 3 pole panel mount male plugs. SGB20-1204 features professional multicore audio cable shielded with aluminiumfoil, XLR fixed in the PC board and independent earth plugs for great reliability, solid aluminium structure.

- Input: 12 XLR 3 pole female
- Output: 4 XLR 3 pole male
- Yongsheng by Neutrik® connectors
- Multicore audio cable shielded with aluminium foil
- Independent earth plugs
- XLR fixed in the PC board
- Multicore Cable lenght: 20 mt

CODE	MSRP EUR	MSRP GBP
D741D	€273,81	£251.36



SGBX10-0008 - 8 inputs 15 meters professional stage box

STAGEBOX SGBX10-0008 15 MT is a professional stage box featuring 8 XLR 3 pole female sockets input. Built in epoxy finished aluminium box, features small dimension and weight thanks to its professional printed circuit and integrated handle. Hi quality XLR connectors Yongsheng by Neutrik® and cable mount connections protected with PVC jackets, ensures high quality connections and signal transmission. Independent earth plugs consist an additional construction advantage.

- Input: 8 XLR 3 pole female
- Independent earth plugs
- Hi quality XLR connectors Yongsheng by Neutrik®
- Metal box
- Multicore cable lenght: 15 mt
- Cable mount connection protected with PVC jackets



CODE	MSRP EUR	MSRP GBP
R112R	€116,25	£106.72

SGBX20-1204 - Professional aluminium stage box featuring 12 in/ 4 out

SGB20-1204 is a professional stage box with 12 XLR 3 pole panel mount female sockets + 4 XLR 3 pole panel mount male plugs. SGB20-1204 features professional multicore audio cable shielded with aluminiumfoil, XLR fixed in the PC board and independent earth plugs for great reliability, solid aluminium structure.

- Input: 12 XLR 3 pole female
- Output: 4 XLR 3 pole male
- Yongsheng by Neutrik® connectors
- Multicore audio cable shielded with aluminium foil
- Independent earth plugs
- XLR fixed in the PC board
- Multicore Cable lenght: 15 mt



CODE	MSRP EUR	MSRP GBP
N806N	€203,22	£186.56

SGBX20-1604 - Professional aluminium stage box featuring 16 in/ 4 out

SGBX20-1604 is a professional stage box with 16 XLR 3 pole panel mount female sockets + 4 XLR 3 pole panel mount male plugs. SGB20-1604 features professional multicore audio cable shielded with aluminiumfoil, XLR fixed in the PC board and independent earth plugs for great reliability, solid aluminium structure.

- Input: 16 XLR 3 pole female
- Output: 4 XLR 3 pole male
- Yongsheng by Neutrik® connectors
- Multicore audio cable shielded with aluminium foil
- Independent earth plugs
- XLR fixed in the PC board
- Multicore Cable lenght: 20 mt



CODE	MSRP EUR	MSRP GBP
R110R	€273,81	£251.36

SGBX20-2408 - Professional aluminium stage box featuring 24 in/ 8 out

SGB20-2408 is a professional stage box with 24 XLR 3 pole panel mount female sockets + 8 XLR 3 pole panel mount male plugs. SGB20-2408 features professional multicore audio cable shielded with aluminium foil, XLR fixed in the PC board and independent earth plugs for great reliability, solid aluminium structure.

- Input: 24 XLR 3 pole female
- Output: 8 XLR 3 pole male
- Yongsheng by Neutrik® connectors
- Multicore audio cable shielded with aluminium foil
- Independent earth plugs
- Aluminium box with integrated handle
- XLR fixed in the PC board
- Multicore cable lenght: 30 mt



CODE	MSRP EUR	MSRP GBP
R111R	€524,88	£481.84

SGBX20-1604-30 - Professional aluminium stage box featuring 16 in/ 4 out

SGBX20-1604 is a professional stage box with 16 XLR 3 pole panel mount female sockets + 4 XLR 3 pole panel mount male plugs. SGB20-1604 features professional multicore audio cable shielded with aluminiumfoil, XLR fixed in the PC board and independent earth plugs for great reliability, solid aluminium structure.

- Input: 16 XLR 3 pole female
- Output: 4 XLR 3 pole male
- Yongsheng by Neutrik® connectors
- Multicore audio cable shielded with aluminium foil
- Independent earth plugs
- XLR fixed in the PC board
- Multicore Cable lenght: 30 mt



CODE	MSRP EUR	MSRP GBP
D742D	€331,70	£304.50

SGBX20-3208 - Professional aluminium stage box featuring 32 in/ 8 out

SGB20-3208 is a professional stage box with 32 XLR 3 pole panel mount female sockets + 8 XLR 3 pole panel mount male plugs. SGB20-3208 features professional multicore audio cable shielded with aluminium foil, XLR fixed in the PC board and independent earth plugs for great reliability, solid aluminium structure.

- Input: 32 XLR 3 pole female
- Output: 8 XLR 3 pole male
- Yongsheng by Neutrik® connectors
- Multicore audio cable shielded with aluminium foil
- Independent earth plugs
- XLR fixed in the PC board
- Multicore Cable lenght: 30 mt



CODE	MSRP EUR	MSRP GBP
L906L	€715,71	£657.02

Wiremaster
Series

SBGX10-1204-15MT - Professional metal stage box featuring 12 Input/ 4 Output

The SGBX10-1204-15MT stage box, built in a metal box with an epoxy finish, has a reduced weight and size thanks to its professional printed circuit. Nylon connectors for high quality XLR contacts. Cable assembly connections protected by PVC sheaths and wired with XLR metal connectors fixed to the PC board with independent hearth plugs for maximum reliability.

- Input: 12 XLR 3 Pin Female
- Output: 4 XLR 3 Pin Male
- Numbered 15-meter cable
- Independent earth plugs



CODE	MSRP EUR	MSRP GBP
L877L	€171,01	£156.99

SBGX10-1204-20MT - Professional metal stage box featuring 12 Input/ 4 Output

The SGBX10-1204-20MT stage box, built in a metal box with an epoxy finish, has a reduced weight and size thanks to its professional printed circuit. Nylon connectors for high quality XLR contacts. Cable assembly connections protected by PVC sheaths and wired with XLR metal connectors fixed to the PC board with independent hearth plugs for maximum reliability.

- Input: 12 XLR 3 Pin Female
- Output: 4 XLR 3 Pin Male
- Numbered 15-meter cable
- Independent earth plugs



CODE	MSRP EUR	MSRP GBP
L878L	€191,59	£175.88

SBGX10-1604-20MT - Professional metal stage box featuring 16 Input/ 4 Output

The SGBX10-1604-20MT stage box, built in a metal box with an epoxy finish, has a reduced weight and size thanks to its professional printed circuit. Nylon connectors for high quality XLR contacts. Cable assembly connections protected by PVC sheaths and wired with XLR metal connectors fixed to the PC board with independent hearth plugs for maximum reliability.

- Input: 16 XLR 3 Pin Female
- Output: 4 XLR 3 Pin Male
- Numbered 20-meter cable
- Independent earth plugs



CODE	MSRP EUR	MSRP GBP
L879L	€232,62	£213.55

SBGX10-1604-30MT - Professional metal stage box featuring 16 Input/ 4 Output

The SGBX10-1604-30MT stage box, built in a metal box with an epoxy finish, has a reduced weight and size thanks to its professional printed circuit. Nylon connectors for high quality XLR contacts. Cable assembly connections protected by PVC sheaths and wired with XLR metal connectors fixed to the PC board with independent hearth plugs for maximum reliability.

- Input: 16 XLR 3 Pin Female
- Output: 4 XLR 3 Pin Male
- Numbered 30-meter cable
- Independent earth plugs



CODE	MSRP EUR	MSRP GBP
L880L	€299,53	£274.97

CBLMLT8-10

- Cable Length: 10 Meters
- Single Cable 13 mm
- Numbered single cable



CODE	MSRP EUR	MSRP GBP
L872L	€49,98	£45.88

CBLMLT8-05

- Cable Length: 5 Meters
- Single Cable 13 mm
- Numbered single cable



CODE	MSRP EUR	MSRP GBP
L873L	€38,32	£35.18

CBLMLT8-03

- Cable Length: 3 Meters
- Single Cable 13 mm
- Numbered single cable



CODE	MSRP EUR	MSRP GBP
L874L	€33,62	£30.86

Soundsation WIREMASTER series is a professional line of microphone, instrument, power and patch cables featuring YONGSHENG/REAN by NEUTRIK® premium quality connectors and Oxygen Free Copper technology. Conceived to provide users with hi performance products and built with top selected materials, WIREMASTER series means superior quality construction and shielding, fully preserved tone and unmatched durability.

WM-BXX Series

- XLR(M)-XLR(F) Yongsheng by Neutrik® connectors
- O.F.C. construction
- Large wire diameter of 2x0.30 mm² for high transmission quality
- Cable diameter: 6.5mm
- Dense copper braided shielding (95%) for noiseless performances
- PE insulation grants very low capacity
- Flexible, easy winding
- Application: stage, mobile, studio, installations

- Wire diameter: 2x0.30 mm²
- Cable diameter: 6.5mm
- Shielding: 95% copper
- Connectors: XLR(M)-XLR(F) - Yongsheng by Neutrik®



CODE	MODEL	SIZE	MSRP EUR	MSRP GBP
R323R	WM-BXX05	5mt	€16,94	£15.55
R324R	WM-BXX10	10mt	€25,50	£23.41
R325R	WM-BXX15	15mt	€34,03	£31.24
R326R	WM-BXX20	20mt	€42,74	£39.24

WM-UXFJ Series

- XLR(F)-6.3mm Jack MONO Yongsheng by Neutrik® connectors
- O.F.C. construction
- Large wire diameter of 2x0.30 mm² for high transmission quality
- Cable diameter: 6.5mm
- Dense copper braided shielding (95%) for noiseless performances
- PE insulation grants very low capacity
- Flexible, easy winding
- Application: stage, mobile, studio, installations

- Wire diameter: 2x0.30 mm²
- Cable diameter: 6.5mm



CODICE	MODELLO	MISURA	PREZZO	MSRP GBP
R331R	WM-UXFJ05	5 mt	€17,31	£15.89
R332R	WM-UXFJ10	10 mt	€25,88	£23.76
R333R	WM-UXFJ15	15 mt	€32,80	£30.11
R334R	WM-UXFJ20	20 mt	€43,12	£39.58

WM-UXMJ Series

- XLR(M)-6.3mm Jack MONO Yongsheng by Neutrik® connectors
- O.F.C. construction
- Large wire diameter of 2x0.30 mm² for high transmission quality
- Cable diameter: 6.5mm
- Dense copper braided shielding (95%) for noiseless performances
- PE insulation grants very low capacity
- Flexible, easy winding
- Application: stage, mobile, studio, installations

- Wire diameter: 2x0.30 mm²
- Cable diameter: 6.5mm
- Shielding: 95% copper
- Connectors: XLR(M)-6.3mm Jack MONO - Yongsheng by Neutrik®



CODE	MODEL	SIZE	MSRP EUR	MSRP GBP
R327R	WM-UXMJ05	5 mt	€17,24	£15.83
R328R	WM-UXMJ10	10 mt	€25,84	£23.72
R329R	WM-UXMJ15	15 mt	€34,40	£31.58
R330R	WM-UXMJ20	20 mt	€43,08	£39.55

BM-XLR-MXLR

- Microphone audio cable with XLR M to Mini XLR F connectors
- High Quality anti-interference core
- Length: 6 mt



CODE	MSRP EUR	MSRP GBP
F765F	€12,96	£11.90





Soundsation GO-LINK series is a professional line of assembled cables born to provide full reliability for a wide range of applications. Built in Oxygen Free Copper, the GO-LINK series means quality construction, effective shielding, preserved tone and rugged durability. Available for instruments, microphones, speakers, GO-LINKS series also includes cables for data transmission and digital applications.

BMCXX series
Balanced microphone cable XRL 3P M - XLR 3P F

- XRL 3 pole male - XLR 3 pole female, satin plated Zinc alloy connectors
- O.F.C. construction
- Wire diameter 2x0.22 mm² and fine wire stranding for hi quality transmission
- Cable diameter: 6.0mm
- Copper spiral shielding (95%) for noiseless performances
- Sturdy, with thick and soft PVC jacket
- Flexible, easy winding
- Application: studio and stage, multipurpose connections



CODE	MODEL	SIZE	MSRP EUR	MSRP GBP
I127I	BMCXX-2BK	2mt	€7,00	£6.43
G401G	BMCXX-5BK	5mt	€10,54	£9.68
G402G	BMCXX-10BK	10mt	€15,71	£14.42
G403G	BMCXX-15BK	15mt	€21,04	£19.31
G404G	BMCXX-20BK	20mt	€26,56	£24.38

BMCJX Series
Balanced microphone cable XRL 3P F - 6.3mm Jack MONO

- XRL 3 pole female - 6.3mm Jack MONO, satin plated Zinc alloy connectors
- O.F.C. construction
- Wire diameter 2x0.22 mm² and fine wire stranding for hi quality transmission
- Cable diameter: 6.0mm
- Copper spiral shielding (95%) for noiseless performances
- Sturdy, with thick and soft PVC jacket
- Flexible, easy winding
- Application: studio and stage



CODE	MODEL	SIZE	MSRP EUR	MSRP GBP
G407G	BMCJX-5BK	5mt	€8,63	£7.92
G408G	BMCJX-10BK	10mt	€12,37	£11.36

BMCXJ Series - Balanced microphone cable XRL 3P M - 6.3mm Jack MONO



- XRL 3 pole male - 6.3mm Jack MONO, satin plated Zinc alloy connectors
- O.F.C. construction
- Wire diameter 2x0.22 mm² and fine wire stranding for hi quality transmission
- Cable diameter: 6.0mm
- Copper spiral shielding (95%) for noiseless performances
- Sturdy, with thick and soft PVC jacket
- Flexible, easy winding
- Application: studio and stage

CODE	MODEL	SIZE	MSRP EUR	MSRP GBP
G405G	BMCXJ-5BK	5mt	€8,63	£7.92
G406G	BMCXJ-10BK	10mt	€12,37	£11.36



EASY-CON series provides affordable and reliable solutions for connecting your creativity with the music world. Featuring instrument and microphone cables, EASY-CON means O.F.C. construction, effective shielding, preserved tone and noiseless performances.

EMCXX- Balanced microphone cable XRL 3P M - XRL 3P F

- XRL 3P M - XRL 3P F, nichel plated zinc alloy shell and plastic cap connectors
- O.F.C. construction
- Wire diameter 2x0.22 mm² and fine wire stranding for hi quality transmission
- Cable diameter: 6.0mm
- Copper spiral shielding (95%) for noiseless performances
- Sturdy, with thick and soft PVC jacket
- Flexible, easy winding
- Application: studio and stage



CODE	MODEL	SIZE	MSRP EUR	MSRP GBP
L686L	EMCXX-3BK	3mt	€6,46	£5.93
L687L	EMCXX-5BK	5mt	€8,40	£7.71
L688L	EMCXX-10BK	10mt	€12,68	£11.64

EMCXJ- Cavo microfonico bilanciato XRL 3P F - 6.3mm Jack MONO

- XRL 3 pole female - 6.3mm Jack MONO, nichel plated zinc alloy shell and plastic cap connectors
- O.F.C. construction
- Wire diameter 2x0.22 mm² and fine wire stranding for hi quality transmission
- Cable diameter: 6.0mm
- Copper spiral shielding (95%) for noiseless performances
- Sturdy, with thick and soft PVC jacket
- Flexible, easy winding
- Application: studio and stage



CODE	MODEL	SIZE	MSRP EUR	MSRP GBP
L689L	EMCXJ-5BK	5mt	€7,66	£7.03
L690L	EMCXJ-10BK	10mt	€11,67	£10.71

Wiremaster
Series

WM-ICJJ Series

Soundsation WIREMASTER series is a professional line of microphone, instrument, power and patch cables featuring YONGSHENG/REAN by NEUTRIK® premium quality connectors and Oxygen Free Copper technology. Conceived to provide users with hi performance products and built with top selected materials, WIREMASTER series means superior quality construction and shielding, fully preserved tone and unmatched durability.

- 6.3mm Jack MONO-6.3mm Jack MONO Yongsheng by Neutrik® connectors
- O.F.C. construction
- Special stranding and a wire diameter of 0.50 mm² provides outstanding sound image for instruments
- Cable diameter: 7.0mm
- Combination of copper braided shield and semiconductor shielding for effective double shielding
- High quality jacket PVC ensures unmatched durability
- Flexible, easy winding
- Application: studio and stage, connection of stereo video recorder and DAT-recorder

CODE	MODEL	SIZE	MSRP EUR	MSRP GBP
R366R	WM-ICJJ3	3 mt	€14,10	£12.94
R367R	WM-ICJJ6	6 mt	€19,15	£17.58
R368R	WM-ICJJ9	9 mt	€24,20	£22.22

GO-Link

Soundsation GO-LINK series is a professional line of assembled cables born to provide full reliability for a wide range of applications. Built in Oxygen Free Copper, the GO-LINK series means quality construction, effective shielding, preserved tone and rugged durability. Available for instruments, microphones, speakers, GO-LINKS series also includes cables for data transmission and digital applications.

Serie BICJJ



- 6.3mm Jack MONO - 6.3mm Jack MONO, satin nickel plated Zinc alloy connectors
- O.F.C. construction
- Wire diameter of 0.22 mm² and fine individual stranding for sturdiness and reliability
- Cable diameter: 6.0mm
- Double shielding with copper spiral + semiconductor shielding
- Flexible, easy winding
- Application: studio and stage, connection of stereo video recorder and DAT-recorder

CODE	MODEL	SIZE	MSRP EUR	MSRP GBP
G034G	BICJJ-3BK	3 mt	€7,90	£7.25
G035G	BICJJ-6BK	6 mt	€10,31	£9.46
G036G	BICJJ-9BK	9 mt	€12,64	£11.60

Serie BICMJJ



- 6.3mm Jack MONO - 6.3mm Jack MONO, nickel plated Zinc alloy connectors with cable spring
- O.F.C. construction
- Wire diameter of 0.22 mm² and fine individual stranding for sturdiness and reliability
- Cable diameter: 6.0mm
- Double shielding with copper spiral + semiconductor shielding
- Flexible, easy winding
- Application: studio and stage, connection of stereo video recorder and DAT-recorder

CODE	MODEL	SIZE	MSRP EUR	MSRP GBP
H533H	BICMJJ-3BK	3 mt	€7,04	£6.46
G037G	BICMJJ-6BK	6 mt	€8,91	£8.18
H534H	BICMJJ-9BK	9 mt	€13,46	£12.36

Wiremaster
Series

WM-ICPJJ- Wiremaster unbalanced instrument cable 6.3mm Jack MONO - 6.3mm Jack MONO angled

- 6.3mm Jack MONO - 6.3mm Jack MONO angled Yongsheng by Neutrik® connectors
- O.F.C. construction
- Special stranding and a wire diameter of 0.50 mm² provides outstanding sound image for instruments
- Cable diameter: 7.0mm
- Combination of copper braided shield and semiconductor shielding for effective double shielding
- High quality jacket PVC ensures unmatched durability
- Flexible, easy winding
- Application: studio and stage, connection of stereo video recorder and DAT-recorder

CODE	MODEL	SIZE	MSRP EUR	MSRP GBP
E947E	WM-ICPJJ3	3 mt	€12,90	£11.84
E948E	WM-ICPJJ6	6 mt	€17,95	£16.48
E949E	WM-ICPJJ9	9 mt	€23,04	£21.15



WM-ICPJPJ - Wiremaster unbalanced instrument cable 6.3mm Jack MONO angled - 6.3mm Jack MONO angled

- 6.3mm Jack MONO angled - 6.3mm Jack MONO angled Yongsheng by Neutrik® connectors
- O.F.C. construction
- Special stranding and a wire diameter of 0.50 mm² provides outstanding sound image for instruments
- Cable diameter: 7.0mm
- Combination of copper braided shield and semiconductor shielding for effective double shielding
- High quality jacket PVC ensures unmatched durability
- Flexible, easy winding
- Application: studio and stage, connection of stereo video recorder and DAT-recorder

CODE	MODEL	SIZE	MSRP EUR	MSRP GBP
E950E	WM-ICPJPJ3	3 mt	€12,64	£11.60
E951E	WM-ICPJPJ6	6 mt	€17,73	£16.28
E952E	WM-ICPJPJ9	9 mt	€22,70	£20.84





BICSJJ-6BK



- O.F.C. construction
- Wire diameter 2x0.22 mm² and fine wire stranding for hi quality transmission
- Cable diameter: 6.0mm
- Copper spiral shielding (95%) for noiseless performances
- Length: 6mt

CODE	MSRPEUR	MSRP GBP
H621H	€12,83	£11.78

MICJF-6BK



- 6.3mm Jack MONO - 6.3mm Jack female MONO, nickel plated Zinc alloy connectors with cable spring
- Wire diameter of 0.22 mm² and fine individual stranding for sturdiness and reliability
- Cable diameter: 6.0mm
- Length: 6mt

CODE	MSRPEUR	MSRP GBP
G038G	€9,49	£8.71

MICJJP-6BK



- 6.3mm Jack MONO - 6.3mm angled Jack MONO, nickel plated Zinc alloy connectors with cable spring
- 90° angled golden connectors
- Wire diameter of 0.22 mm² and fine individual stranding for sturdiness and reliability
- Cable diameter: 6.0mm
- Length: 6mt

CODE	MSRPEUR	MSRP GBP
G039G	€9,30	£8.54

MEPSET-100



- 6.3mm Jack MONO - 6.3mm Jack MONO
- 90° angled golden connectors
- Length: 0.2 mt
- Package: 6 pcs

CODE	MSRPEUR	MSRP GBP
H487H	€41,15	£37.78



EASY-CON series provides affordable and reliable solutions for connecting your creativity with the music world. Featuring instrument and microphone cables, EASY-CON means O.F.C. construction, effective shielding, preserved tone and noiseless performances.

EICJJ- Unbalanced instrument cable 6.3mm Jack MONO - 6.3mm Jack MONO

- 6.3mm Jack MONO - 6.3mm Jack MONO nickel plated zinc alloy shell connectors
- O.F.C. construction
- Wire diameter of 0.22 mm² and fine individual stranding for sturdiness and reliability
- Cable diameter: 6.0mm
- Double shielding with copper spiral + semiconductor shielding
- Flexible, easy winding
- Application: studio and stage, connection of stereo video recorder and DAT-recorder
- Shielding: 100%



CODE	MODEL	SIZE	MSRP EUR	MSRP GBP
L680L	EICJJ-3BK	3mt	€5,76	£5.29
L681L	EICJJ-6BK	6mt	€7,70	£7.07
L682L	EICJJ-9BK	9mt	€9,72	£8.92

EICJJP- Unbalanced instrument cable 6.3mm Jack MONO - 6.3mm angled Jack MONO

- 6.3mm Jack MONO - 6.3mm angled Jack MONO nickel plated zinc alloy shell connectors
- O.F.C. construction
- Wire diameter of 0.22 mm² and fine individual stranding for sturdiness and reliability
- Cable diameter: 6.0mm
- Double shielding with copper spiral + semiconductor shielding
- Flexible, easy winding
- Application: studio and stage, connection of stereo video recorder and DAT-recorder
- Length: 6mt
- Shielding: 100%



CODE	MODEL	SIZE	MSRP EUR	MSRP GBP
L684L	EICJJP-6BK	6mt	€8,17	£7.50



Soundsation WIREMASTER series is a professional line of microphone, instrument, power and patch cables featuring YONGSHENG/REAN by NEUTRIK® premium quality connectors and Oxygen Free Copper technology. Conceived to provide users with hi performance products and built with top selected materials, WIREMASTER series means superior quality construction and shielding, fully preserved tone and unmatched durability.

WM-PCJJ - Speaker Cable Jack-Jack

- 6.3mm Jack MONO-6.3mm Jack MONO, Yongsheng by Neutrik® connectors
- O.F.C. construction
- Large wire diameter of 1x2.5 mm² for high transmission quality
- Cable diameter: 7.0mm
- Noiseless performances
- High quality jacket PVC ensures unmatched durability
- Flexible, easy winding
- Application: sound systems, installations



CODE	MODEL	SIZE	MSRPEUR	MSRP GBP
R377R	WM-PCJJ1	1mt	€12,04	£11.05
R378R	WM-PCJJ2	2mt	€13,99	£12.84
R379R	WM-PCJJ5	5mt	€19,93	£18.30
R380R	WM-PCJJ10	10mt	€29,84	£27.39
R381R	WM-PCJJ15	15mt	€39,68	£36.43

WM-PCSS - Speaker Cable Speakon-Speakon

- Speakon-Speakon REAN by Neutrik® connectors
- O.F.C. construction
- Large wire diameter of 2x2.5 mm² for high transmission quality
- Cable diameter: 8.0mm
- Noiseless performances
- High quality jacket PVC ensures unmatched durability
- Flexible, easy winding
- Application: sound systems, installations



CODE	MODEL	SIZE	MSRPEUR	MSRP GBP
R369R	WM-PCSS1	1mt	€23,60	£21.66
R370R	WM-PCSS5	5mt	€37,06	£34.02
R371R	WM-PCSS10	10mt	€53,89	£49.47
R372R	WM-PCSS15	15mt	€70,49	£64.71
R373R	WM-PCSS20	20mt	€87,06	£79.92

WM-PCSJ - Speaker Cable Speakon-Jack

- Speakon-6.3mm Jack MONO, REAN/Yongsheng by Neutrik® connectors
- O.F.C. construction
- Large wire diameter of 2x1.5 mm² for high transmission quality
- Cable diameter: 7.0mm
- Noiseless performances
- High quality jacket PVC ensures unmatched durability
- Flexible, easy winding
- Application: sound systems, installations



CODE	MODEL	SIZE	MSRPEUR	MSRP GBP
R374R	WM-PCSJ2	2mt	€19,67	£18.06
R375R	WM-PCSJ5	5mt	€25,99	£23.86
R376R	WM-PCSJ10	10mt	€35,45	£32.54

WM-PCX - Speaker cable XLR (M)-XLR (F)

- XLR(M)-XLR(F), Yongsheng by Neutrik® connectors
- O.F.C. construction
- Large wire diameter of 2x2.5 mm² for high transmission quality
- Cable diameter: 8.0mm
- Noiseless performances
- High quality jacket PVC ensures unmatched durability
- Flexible, easy winding
- Application: sound systems, installations



CODE	MODEL	SIZE	MSRPEUR	MSRP GBP
R382R	WM-PCX5	5mt	€25,17	£23.11
R383R	WM-PCX10	10mt	€41,55	£38.14
R384R	WM-PCX15	15mt	€58,04	£53.28

Wiremaster

Series

WM-PCXFJ - Speaker Cable XLR(F)-Jack

- XLR(F)-6.3mm Jack MONO, Yongsheng by Neutrik® connectors
- O.F.C. construction
- Large wire diameter of 1x2.5 mm² for high transmission quality
- Cable diameter: 7.0mm
- Noiseless performances
- High quality jacket PVC ensures unmatched durability
- Flexible, easy winding
- Application: sound systems, installations



CODE	MODEL	SIZE	MSRPEUR	MSRPGBP
R385R	WM-PCXFJ5	5mt	€18,81	£17.27
R386R	WM-PCXFJ10	10mt	€28,72	£26.36
R387R	WM-PCXFJ15	15mt	€38,63	£35.46

WM-PCXMJ - Speaker Cable XLR(M)-Jack

- XLR(M)-6.3mm Jack MONO, Yongsheng by Neutrik® connectors
- O.F.C. construction
- Large wire diameter of 1x2.5 mm² for high transmission quality
- Cable diameter: 7.0mm
- Noiseless performances
- High quality jacket PVC ensures unmatched durability
- Flexible, easy winding
- Application: sound systems, installations



CODE	MODEL	SIZE	MSRPEUR	MSRPGBP
R388R	WM-PCXMJ5	5mt	€18,77	£17.23
R389R	WM-PCXMJ10	10mt	€28,65	£26.30
R390R	WM-PCXMJ15	15mt	€38,59	£35.43

Soundsation GO-LINK series is a professional line of assembled cables born to provide full reliability for a wide range of applications. Built in Oxygen Free Copper, the GO-LINK series means quality construction, effective shielding, preserved tone and rugged durability. Available for instruments, microphones, speakers, GO-LINKS series also includes cables for data transmission and digital applications.

GO-Link

BPCJJ - Power Cable

- 6.3mm Jack MONO - 6.3mm Jack MONO, nickel plated Zinc alloy connectors with springs
- O.F.C. construction
- Wire diameter of 2x1.3 mm²
- Cable diameter: 6.0mm
- Noiseless performances
- Soft PVC jacket
- Flexible, easy winding
- Application: sound systems, install



CODE	MODEL	SIZE	MSRPEUR	MSRPGBP
G101G	BPCJJ-10BK	10mt	€21,27	£19.53
G102G	BPCJJ-15BK	15mt	€31,62	£29.03

BPCJX - Power Cable

- XLR 3 poles female - 6.3mm Jack MONO, nickel plated Zinc alloy connectors with springs
- O.F.C. construction
- Wire diameter of 2x1.3 mm²
- Cable diameter: 6.0mm
- Noiseless performances
- Soft PVC jacket
- Flexible, easy winding
- Application: sound systems, install



CODE	MODEL	SIZE	MSRPEUR	MSRPGBP
G103G	BPCJX-10BK	10mt	€23,76	£21.81
G104G	BPCJX-15BK	15mt	€33,18	£30.46

BPCXJ - Power Cable

- XLR 3 poles male - 6.3mm Jack MONO, nickel plated Zinc alloy connectors with springs
- O.F.C. construction
- Wire diameter of 2x1.3 mm²
- Cable diameter: 6.0mm
- Noiseless performances
- Soft PVC jacket
- Flexible, easy winding
- Application: sound systems, installa



CODE	MODEL	SIZE	MSRPEUR	MSRPGBP
G105G	BPCXJ-10BK	10mt	€23,76	£21.81
G106G	BPCXJ-15BK	15mt	€33,18	£30.46

BPCXX - Power Cable

- XLR 3 poles female - XLR 3 poles male, nickel plated Zinc alloy connectors with springs
- O.F.C. construction
- Wire diameter of 2x1.3 mm²
- Cable diameter: 6.0mm
- Noiseless performances
- Soft PVC jacket
- Flexible, easy winding
- Application: sound systems, installa



CODE	MODEL	SIZE	MSRPEUR	MSRPGBP
G107G	BPCXX-10BK	10mt	€23,72	£21.77
G108G	BPCXX-15BK	15mt	€33,99	£31.20

BPSPK - Power Speaker Cable

- Speakon 4P - Speakon 4P, plastic connectors with cable strain relief
- O.F.C. construction
- Wire diameter of 2x1.5 mm²
- Cable diameter: 7.0mm
- Noiseless performances
- Soft PVC jacket
- Flexible, easy winding
- Application: sound systems, installations



CODE	MODEL	SIZE	MSRPEUR	MSRPGBP
I324I	BPSPK-1BK	1mt	€8,01	£7.35
I325I	BPSPK-5BK	5mt	€17,97	£16.50
I326I	BPSPK-10BK	10mt	€28,31	£25.99
I327I	BPSPK-15BK	15mt	€40,18	£36.89

Professional analog signal and electric power combination cable for active speakers featuring the best solution for both connecting and powering your active systems.

PF100-10 - Audio signal and electric power combination cable for active speakers (3x1.5mm² - 2x0.22mm²)

- XLR 3 pole female plug + Schuko 203A
- XLR 3 pole male plug + EC standard 3 pole female socket
- Power cable: 3x1.5mm²
- Conductors: 2x0.22mm²
- Cable diameter: 7.0mm



CODE	MODEL	SIZE	MSRP EUR	MSRP GBP
I302I	PF100-5	5mt	€34,67	£31.83
I303I	PF100-10	10mt	€61,67	£56.61
I304I	PF100-15	15mt	€93,64	£85.96
I305I	PF100-20	20mt	€119,82	£109.99

PF200-10 - Audio signal and electric power combination cable for active speakers (3x2.5mm² - 2x0.22mm²)

- XLR 3 pole female plug + Schuko 203A
- XLR 3 pole male plug + EC standard 3 pole female socket
- Power cable: 3x2.5mm²
- Conductors: 2x0.22mm²
- Cable diameter: 7.0mm



CODE	MODEL	SIZE	MSRP EUR	MSRP GBP
I306I	PF200-5	5mt	€46,82	£42.98
I307I	PF200-10	10mt	€85,04	£78.07
I308I	PF200-15	15mt	€124,31	£114.12
I309I	PF200-20	20mt	€160,66	£147.49

PF-300- Audio signal and electric power combination cable for active speakers (3x2.5mm² - 2x0.22mm²)

- XLR 3 pole female plug + Yongsheng by Neutrik powercon
- XLR 3 pole male plug + EC standard 3 pole female socket
- Power cable: 3x2.5mm²
- Conductors: 2x0.22mm²
- Cable diameter: 7.0mm



CODE	MODEL	SIZE	MSRP EUR	MSRP GBP
L541L	PF300-5	5mt	€51,29	£47.08
L542L	PF300-10	10mt	€85,71	£78.68
L543L	PF300-15	15mt	€136,80	£125.58
L544L	PF300-20	20mt	€167,72	£153.97

Wiremaster Series

Soundsation WIREMASTER series is a professional line of microphone, instrument, power and patch cables featuring YONGSHENG/REAN by NEUTRIK® premium quality connectors and Oxygen Free Copper technology. Conceived to provide users with hi performance products and built with top selected materials, WIREMASTER series means superior quality construction and shielding, fully preserved tone and unmatched durability. Shielding: 95% copper

WM-MJ2RCA- Wiremaster adapter cable Mini jack stereo 3.5 - 2 x RCA

- Mini jack 3.5 stereo - 2 x RCA Yongsheng by Neutrik® connectors
- O.F.C. construction
- Large wire diameter of 2x0.22 mm² for high transmission quality
- Cable diameter: 5mm flying / 5.5mm main
- Dense copper braided shielding (100%) for noiseless performances
- PE insulation grants very low capacity
- Flexible, easy winding
- Application: multipurpose connection



CODE	MODEL	SIZE	MSRP EUR	MSRP GBP
E924E	WM-MJ2RCA15	1,5 mt	€15,97	£14.66
E925E	WM-MJ2RCA30	3 mt	€17,13	£15.73

WM-MJMJ- Wiremaster adapter cable Mini Jack stereo 3.5 - Mini jack stereo 3.5

- Mini Jack stereo 3.5mm - Mini jack stereo 3.5mm Yongsheng by Neutrik® connectors
- O.F.C. construction
- Large wire diameter of 2x0.30 mm² for high transmission quality
- Cable diameter: 6.5mm
- Dense copper braided shielding (95%) for noiseless performances
- PE insulation grants very low capacity
- Flexible, easy winding
- Application: multipurpose connection



CODE	MODEL	SIZE	MSRP EUR	MSRP GBP
E927E	WM-MJMJ15	1,5 mt	€9,12	£8.37
E928E	WM-MJMJ30	3 mt	€11,71	£10.75

WM_MJ"J - Wiremaster adapter cable Mini jack stereo 3,5 - 2 x Jack 6,3 Mono

- Mini jack stereo 3,5 - 2 x Jack 6,3 Mono Yongsheng by Neutrik® connectors
- O.F.C. construction
- Large wire diameter of 2x0.22 mm² for high transmission quality
- Cable diameter: 5mm flying / 5.5mm main
- Dense copper braided shielding (100%) for noiseless performances
- PE insulation grants very low capacity
- Flexible, easy winding
- Application: multipurpose connection



CODE	MODEL	SIZE	MSRP EUR	MSRP GBP
E932E	WM-MJ2J15	1,5 mt	€13,65	£12.53
E933E	WM-MJ2J30	3 mt	€14,73	£13.52



WM-2RCA2RCA - Wiremaster adapter cable 2 x RCA - 2 x RCA

- 2 x RCA - 2 x RCA Yongsheng by Neutrik® connectors
- O.F.C. construction
- Large wire diameter of 2x1x0.22 mm² for high transmission quality
- Cable diameter: 5mm
- Dense copper braided shielding (90%) for noiseless performances
- PE insulation grants very low capacity
- Flexible, easy winding
- Application: multipurpose connection

CODE	MODEL	SIZE	MSRP EUR	MSRP GBP
E926E	WM-2RCA2RCA15	1,5 mt	€22,03	£20.22
E929E	WM-2RCA2RCA30	3 mt	€22,92	£21.04
E931E	WM-2RCA2RCA50	5 mt	€26,25	£24.10



WM-MJ2XLR- Wiremaster adapter cable Mini jack stereo 3.5 - 2 x XLR Male / 1.5 mt

- Mini jack stereo 3.5 - 2 x XLR Male Yongsheng by Neutrik® connectors
- O.F.C. construction
- Large wire diameter of 2x0.22 mm² for high transmission quality
- Cable diameter: 5mm flying / 5.5mm main
- Dense copper braided shielding (100%) for noiseless performances
- PE insulation grants very low capacity
- Flexible, easy winding
- Application: multipurpose connection

CODE	MODEL	SIZE	MSRP EUR	MSRP GBP
E937E	WM-MJ2XLR15	1,5 mt	€12,86	£11.81
E938E	WM-MJ2XLR30	3 mt	€14,02	£12.87



WM-MJXLRM- Wiremaster adapter cable Mini jack stereo 3.5 - Male XLR / 3 mt

- Mini jack stereo 3.5 - Male XLR Yongsheng by Neutrik® connectors
- O.F.C. construction
- Large wire diameter of 2x0.30 mm² for high transmission quality
- Cable diameter: 6.5mm
- Dense copper braided shielding (95%) for noiseless performances
- PE insulation grants very low capacity
- Flexible, easy winding
- Application: multipurpose connection
- Length: 3mt

CODE	MODEL	MSRP EUR	MSRP GBP
E935E	WM-MJXLRM15	€9,69	£8.90
E936E	WM-MJXLRM30	€12,27	£11.26



WM-MJ2J50- Wiremaster adapter cable Mini jack stereo 3,5 - 2 x Jack 6,3 Mono / 5mt

- Mini jack stereo 3,5 - 2 x Jack 6,3 Mono Yongsheng by Neutrik® connectors
- O.F.C. construction
- Large wire diameter of 2x0.22 mm² for high transmission quality
- Cable diameter: 5mm flying / 5.5mm main
- Dense copper braided shielding (100%) for noiseless performances
- PE insulation grants very low capacity
- Flexible, easy winding
- Application: multipurpose connection
- Length: 5mt

CODE	MSRP EUR	MSRP GBP
E934E	€16,16	£14.83



WM-JRCA - Unbalanced patch cable Jack MONO-RCA

- 6.3mm Jack MONO-RCA Yongsheng by Neutrik® connectors
- O.F.C. construction
- Large wire diameter of 2x0.30 mm² for high transmission quality
- Cable diameter: 6.5mm
- Dense copper braided shielding (95%) for noiseless performances
- PE insulation grants very low capacity
- Flexible, easy winding
- Application: multipurpose connection

CODE	MODEL	SIZE	MSRP EUR	MSRP GBP
R363R	WM-JRCA06	0.6mt	€11,11	£10.20
R364R	WM-JRCA09	0.9mt	€11,63	£10.68
R365R	WM-JRCA15	1.5mt	€12,64	£11.60



WM-PJJ - Unbalanced patch cable Jack MONO-Jack MONO

- 6.3mm Jack MONO-6.3mm Jack MONO Yongsheng by Neutrik® connectors
- O.F.C. construction
- Large wire diameter of 2x0.30 mm² for high transmission quality
- Cable diameter: 6.5mm
- Dense copper braided shielding (95%) for noiseless performances
- PE insulation grants very low capacity
- Flexible, easy winding
- Application: multipurpose connection

CODE	MODEL	SIZE	MSRP EUR	MSRP GBP
R360R	WM-PJJ06	0.6mt	€10,13	£9.30
R361R	WM-PJJ09	0.9mt	€10,66	£9.79
R362R	WM-PJJ15	1.5mt	€11,74	£10.78



WM-PRCA - Unbalanced patch cable Jack MONO-RCA

- RCA-RCA Yongsheng by Neutrik® connectors
- O.F.C. construction
- Large wire diameter of 2x0.30 mm² for high transmission quality
- Cable diameter: 6.5mm
- Dense copper braided shielding (95%) for noiseless performances
- PE insulation grants very low capacity
- Flexible, easy winding
- Application: multipurpose connection

CODE	MODEL	SIZE	MSRP EUR	MSRP GBP
R357R	WM-PRCA06	0.6mt	€11,97	£10.99
R358R	WM-PRCA09	0.9mt	€12,53	£11.50
R359R	WM-PRCA15	1.5mt	€13,54	£12.43





WM-PJSJS - Balanced patch cable Jack STEREO-Jack STEREO

- 6.3mm Jack STEREO-6.3mm Jack STEREO Yongsheng by Neutrik® connectors
- O.F.C. construction
- Large wire diameter of 2x0.30 mm² for high transmission quality
- Cable diameter: 6.5mm
- Dense copper braided shielding (95%) for noiseless performances
- PE insulation grants very low capacity
- Flexible, easy winding
- Application: multipurpose connection



CODE	MODEL	SIZE	MSRP EUR	MSRP GBP
R348R	WM-PJSJS05	0.5mt	€12,00	£11.02
R349R	WM-PJSJS1	1mt	€12,86	£11.81
R350R	WM-PJSJS2	1.5mt	€14,58	£13.38

WM-PXFRCA - Balanced patch cable XLR(F)-RCA

- XLR(F)-RCA Yongsheng by Neutrik® connectors
- O.F.C. construction
- Large wire diameter of 2x0.30 mm² for high transmission quality
- Cable diameter: 6.5mm
- Dense copper braided shielding (95%) for noiseless performances
- PE insulation grants very low capacity
- Flexible, easy winding
- Application: multipurpose connection



CODE	MODEL	SIZE	MSRP EUR	MSRP GBP
R351R	WM-PXFRCA06	0.6mt	€10,77	£9.89
R352R	WM-PXFRCA09	0.9mt	€11,22	£10.30
R353R	WM-PXFRCA15	1.5mt	€12,30	£11.29

WM-PXMRCA - Balanced patch cable XLR(M)-RCA

- XLR(M)-RCA Yongsheng by Neutrik® connectors
- O.F.C. construction
- Large wire diameter of 2x0.30 mm² for high transmission quality
- Cable diameter: 6.5mm

- Dense copper braided shielding (95%) for noiseless performances
- PE insulation grants very low capacity
- Flexible, easy winding
- Application: multipurpose connection



CODE	MODEL	SIZE	MSRP EUR	MSRP GBP
R354R	WM-PXMRCA06	0.6mt	€10,66	£9.79
R355R	WM-PXMRCA09	0.9mt	€11,18	£10.26
R356R	WM-PXMRCA15	1.5mt	€12,27	£11.26



WM-PXFJS - Balanced patch cable XLR(F)-Jack STEREO

- XLR(F)-6.3mm Jack STEREO Yongsheng by Neutrik® connectors
- O.F.C. construction
- Large wire diameter of 2x0.30 mm² for high transmission quality
- Cable diameter: 6.5mm
- Dense copper braided shielding (95%) for noiseless performances
- PE insulation grants very low capacity
- Flexible, easy winding
- Application: multipurpose connection



CODE	MODEL	SIZE	MSRP EUR	MSRP GBP
R343R	WM-PXFJS05	0.5mt	€10,58	£9.71
R344R	WM-PXFJS1	1mt	€11,44	£10.50
R345R	WM-PXFJS2	2mt	€13,16	£12.08
R346R	WM-PXFJS5	5mt	€18,29	£16.79
R347R	WM-PXFJS10	10mt	€26,85	£24.65

WM-PXMJS - Balanced patch cable XLR(M)-Jack STEREO

- XLR(M)-6.3mm Jack STEREO Yongsheng by Neutrik® connectors
- O.F.C. construction
- Large wire diameter of 2x0.30 mm² for high transmission quality
- Cable diameter: 6.5mm
- Dense copper braided shielding (95%) for noiseless performances
- PE insulation grants very low capacity
- Flexible, easy winding
- Application: multipurpose connection



CODE	MODEL	SIZE	MSRP EUR	MSRP GBP
R338R	WM-PXMJS05	0.5mt	€11,29	£10.36
R339R	WM-PXMJS1	1mt	€11,48	£10.54
R340R	WM-PXMJS2	2mt	€12,90	£11.84
R341R	WM-PXMJS5	5mt	€18,36	£16.85
R342R	WM-PXMJS10	10mt	€26,93	£24.72



Soundsation GO-LINK series is a professional line of assembled cables born to provide full reliability for a wide range of applications. Built in Oxigen Free Copper, the GO-LINK series means quality construction, effective shielding, preserved tone and rugged durability. Available for instruments, microphones, speakers, GO-LINKS series also includes cables for data transmission and digital applications. O.F.C. construction Copper spiral shielding (90%) for noiseless performances Every conductor is insulated and individually shielded

GL-2AJM2AJM - Adapter cable angled Jack

- 2x6.3mm angled Jack male MONO - 2x6.3mm angled Jack male MONO, moulded connectors
- Wire diameter 2x1x0.14 mm² and fine wire stranding for hi quality transmission
- Cable diameter: 4.0mmx8.0mm
- Application: multipurpose connections



CODE	MODEL	SIZE	MSRPEUR	MSRP GBP
R395R	GL-2AJM2AJM06	0.6mt	€5,29	£4.86
R396R	GL-2AJM2AJM15	1.5mt	€5,99	£5.50
R397R	GL-2AJM2AJM3	3mt	€7,55	£6.93
R398R	GL-2AJM2AJM6	6mt	€10,38	£9.53

GL-2RCA2XM1 - Unbalanced adapter cable 2xRCA male - 2xXLR male

- 2xRCA male - 2xXLR male, moulded connectors
- O.F.C. construction
- Wire diameter 2x1x0.14 mm² and fine wire stranding for hi quality transmission
- Cable diameter: 4.0mmx8.0mm
- Copper spiral shielding (90%) for noiseless performances
- Every conductor is insulated and individually shielded
- Individual stranding ensures flexibility
- Application: multipurpose connections



CODE	MODEL	SIZE	MSRPEUR	MSRP GBP
R402R	GL-2RCA2XM1	1mt	€6,65	£6.10
R403R	GL-2RCA2XM3	3mt	€8,25	£7.57
R404R	GL-2RCA2XM6	6mt	€10,97	£10.07

GL-2RCA2XF - Unbalanced adapter cable 2xRC-2xXLR male

- 2xRCA male - 2xXLR male, moulded connectors
- Wire diameter 2x1x0.14 mm² and fine wire stranding for hi quality transmission
- Cable diameter: 4.0mmx8.0mm
- Individual stranding ensures flexibility
- Application: multipurpose connections



CODE	MODEL	SIZE	MSRPEUR	MSRP GBP
R399R	GL-2RCA2XF1	1mt	€6,65	£6.10
R400R	GL-2RCA2XF3	3mt	€8,25	£7.57
R401R	GL-2RCA2XF6	6mt	€10,97	£10.07

GL-2JM2JM - Adapter cable Jack male MONO

- 2x6.3mm Jack male MONO - 2x6.3mm Jack male MONO, moulded connectors
- Wire diameter 2x1x0.14 mm² and fine wire stranding for hi quality transmission
- Cable diameter: 4.0mmx8.0mm
- Application: multipurpose connections



CODE	MODEL	SIZE	MSRPEUR	MSRP GBP
R391R	GL-2JM2JM06	0.6mt	€4,98	£4.57
R392R	GL-2JM2JM15	1.5mt	€5,76	£5.29
R393R	GL-2JM2JM3	3mt	€7,16	£6.57
R394R	GL-2JM2JM6	6mt	€9,92	£9.11

GL-2RCAM2RCAF - Adapter cable 2xRCA male - 2xRCA female / 3mt

- 2xRCA male - 2xRCA female, moulded connectors
- O.F.C. construction
- Wire diameter 2x1x0.22 mm² and fine wire stranding for hi quality transmission
- Cable diameter: 4.0mmx8.0mm
- Copper spiral shielding (90%) for noiseless performances
- Every conductor is insulated and individually shielded



CODE	MSRPEUR	MSRP GBP
E820E	€6,73	£6.18

GL-AJSmJSm - Adapter cable angled Jack STEREO-Jack male STEREO

- 3.5mm angled Jack male STEREO - 3.5mm Jack male STEREO, moulded connectors
- Wire diameter 2x1x0.14 mm² and fine wire stranding for hi quality transmission
- Cable diameter: 4.0mmx8.0mm
- Individual stranding ensures flexibility
- Application: multipurpose connections



CODE	MODEL	SIZE	MSRPEUR	MSRP GBP
R407R	GL-AJSmJSm15	1.5mt	€4,01	£3.68
R408R	GL-AJSmJSm3	3mt	€4,86	£4.46



GL-JS2JSF - Y adapter cable

- 6.3mm Jack male STEREO - 2x6.3mm Jack female STEREO, moulded connectors
- Wire diameter 2x1x0.14 mm² and fine wire stranding for hi quality transmission
- Cable diameter: 4.0mmx8.0mm
- Application: multipurpose connections



CODE	MODEL	SIZE	MSRPEUR	MSRP GBP
R421R	GL-JSm2JSF02	0.2mt	€6,85	£6.29
R419R	GL-JS2JSF02	3mt	€7,23	£6.64

GL-JSm2XF - Balanced Y adapter cable

- 3.5mm Jack male STEREO - 2xXLR 3P female, moulded connectors
- Wire diameter 2x1x0.14 mm² and fine wire stranding for hi quality transmission
- Cable diameter: 4.0mmx8.0mm
- Individual stranding ensures flexibility
- Application: multipurpose connections



CODE	MODEL	SIZE	MSRPEUR	MSRP GBP
R415R	GL-JSm2XF1	1.5mt	€6,65	£6.10
R416R	GL-JSm2XF3	3mt	€8,52	£7.82

GL-JSmJS - Adapter cable Jack M/F STEREO

- 3.5mm Jack male STEREO - 6.3mm Jack male STEREO, moulded connectors
- Wire diameter 2x1x0.14 mm² and fine wire stranding for hi quality transmission
- Cable diameter: 4.0mmx8.0mm
- Individual stranding ensures flexibility
- Application: multipurpose connections



CODE	MODEL	SIZE	MSRPEUR	MSRP GBP
R411R	GL-JSmJS15	1.5mt	€4,20	£3.86
R412R	GL-JSmJS3	3mt	€5,02	£4.61

GL-JSmJSFm - Adapter cable Jack M/F STEREO

- 3.5mm Jack male STEREO - 3.5mm Jack female STEREO, moulded connectors
- Wire diameter 2x1x0.14 mm² and fine wire stranding for hi quality transmission
- Cable diameter: 4.0mmx8.0mm
- Individual stranding ensures flexibility
- Application: multipurpose connections



CODE	MODEL	SIZE	MSRPEUR	MSRP GBP
R409R	GL-JSmJSFm15	1.5 mt	€4,01	£3.68
R410R	GL-JSmJSFm3	3 mt	€4,86	£4.46

GL-JS2JSFm - Y adapter cable

- 3.5mm Jack male STEREO - 2x3.5mm Jack female STEREO, moulded connectors
- Wire diameter 2x1x0.14 mm² and fine wire stranding for hi quality transmission
- Cable diameter: 4.0mmx8.0mm
- Application: multipurpose connections



CODE	MODEL	SIZE	MSRPEUR	MSRP GBP
R420R	GL-JS2JSFm02	0.2mt	€5,41	£4.97
R422R	GL-JSm2JSFm02	0.2mt	€4,55	£4.18

GL-JSm2XM - Balanced Y adapter cable

- 3.5mm Jack male STEREO - 2xXLR 3P male, moulded connectors
- Wire diameter 2x1x0.14 mm² and fine wire stranding for hi quality transmission
- Cable diameter: 4.0mmx8.0mm
- Individual stranding ensures flexibility
- Application: multipurpose connections



CODE	MODEL	SIZE	MSRPEUR	MSRP GBP
R417R	GL-JSm2XM1	1.5mt	€6,61	£6.07
R418R	GL-JSm2XM3	3mt	€8,52	£7.82

GL-JSmJSF - Adapter cable Jack M/F STEREO

- 3.5mm Jack male STEREO - 6.3mm Jack female STEREO, moulded connectors
- Wire diameter 2x1x0.14 mm² and fine wire stranding for hi quality transmission
- Cable diameter: 4.0mmx8.0mm
- Individual stranding ensures flexibility
- Application: multipurpose connections



CODE	MODEL	SIZE	MSRPEUR	MSRP GBP
R413R	GL-JSmJSF15	1.5mt	€5,68	£5.21
R414R	GL-JSmJSF3	3 mt	€6,38	£5.86

GL-JSmJSm - Adapter cable Jack M/M STEREO

- 3.5mm Jack male STEREO - 3.5mm Jack male STEREO, moulded connectors
- Wire diameter 2x1x0.14 mm² and fine wire stranding for hi quality transmission
- Cable diameter: 4.0mmx8.0mm
- Individual stranding ensures flexibility
- Application: multipurpose connections



CODE	MODEL	SIZE	MSRPEUR	MSRP GBP
R405R	GL-JSmJSm15	1.5mt	€3,66	£3.36
R406R	GL-JSmJSm3	3mt	€4,43	£4.07



JJJ-15BK - Y-Adapter cable Jack m/m STEREO-MONO

- 6.3mm Jack male STEREO - 2x6.3mm Jack male MONO, moulded connectors
- Wire diameter 2x1x0.14 mm² and fine wire stranding for hi quality transmission
- Cable diameter: 4.0mmx8.0mm
- Individual stranding ensures flexibility
- Application: multipurpose connections



CODE	MODEL	SIDE	MSRPEUR	MSRP GBP
I125I	JJJ-15BK	1.5mt	€4,82	£4.42
I126I	JJJ-30BK	3mt	€6,22	£5.71

JRR-15BK - Adapter cable Jack male STERE-2xRCA male

- 6.3mm Jack male STEREO - 2xRCA male, moulded connectors
- Wire diameter 2x1x0.14 mm² and fine wire stranding for hi quality transmission
- Cable diameter: 4.0mmx8.0mm
- Individual stranding ensures flexibility
- Application: multipurpose connections



CODE	MODEL	SIDE	MSRPEUR	MSRP GBP
H617H	JRR-15BK	1.5mt	€4,04	£3.71
H618H	JRR-30BK	3mt	€5,60	£5.14
I080I	JRR-50BK	5mt	€6,81	£6.25

SJJJ-15BK - Y-Adapter cable Jack male STEREO-MONO

- 3.5mm Jack male STEREO - 2x6.3mm Jack male MONO, moulded connectors
- Wire diameter 2x1x0.14 mm² and fine wire stranding for hi quality transmission
- Cable diameter: 4.0mmx8.0mm
- Individual stranding ensures flexibility
- Application: multipurpose connections



CODE	MODEL	SIDE	MSRPEUR	MSRP GBP
H611H	SJJJ-15BK	1.5mt	€4,59	£4.21
H612H	SJJJ-30BK	3mt	€5,95	£5.46
I076I	SJJJ-50BK	5mt	€7,62	£7.00

JJRR-15BK - Cavo adattatore Jack maschio STEREO

- 2x6.3mm Jack male STEREO - 2xRCA male, moulded connectors
- Wire diameter 2x1x0.14 mm² and fine wire stranding for hi quality transmission
- Cable diameter: 4.0mmx8.0mm
- Individual stranding ensures flexibility
- Application: multipurpose connections



CODE	MODEL	SIDE	MSRPEUR	MSRP GBP
H613H	JJRR-15BK	1.5mt	€4,71	£4.32
H614H	JJRR-30BK	3mt	€5,76	£5.29
I078I	JJRR-50BK	5mt	€7,70	£7.07

RRRR-15BK - Adapter cable 2x2 RCA male

- 2xRCA male - 2xRCA male, moulded connectors
- Wire diameter 2x1x0.14 mm² and fine wire stranding for hi quality transmission
- Cable diameter: 4.0mmx8.0mm
- Individual stranding ensures flexibility
- Application: multipurpose connections



CODE	MODEL	SIDE	MSRPEUR	MSRP GBP
H615H	RRRR-15BK	1.5mt	€4,43	£4.07
H616H	RRRR-30BK	3mt	€6,03	£5.54
I079I	RRRR-50BK	5mt	€7,04	£6.46

SJRR-15BK - Cavo adattatore a Y Jack M/M STEREO

- 3.5mm Jack male STEREO - 2xRCA male, moulded connectors
- Wire diameter 2x1x0.14 mm² and fine wire stranding for hi quality transmission
- Cable diameter: 4.0mmx8.0mm
- Individual stranding ensures flexibility
- Application: multipurpose connections



CODE	MODEL	SIDE	MSRPEUR	MSRP GBP
H619H	SJRR-15BK	1.5mt	€3,81	£3.50
H620H	SJRR-30BK	3mt	€5,17	£4.75
I077I	SJRR-50BK	5mt	€7,23	£6.64



WIREMASTER WM-USB series

Soundsation Wiremaster series offers cables specifically designed for professional applications related to the entertainment world. Wiremaster USB cables comply with the USB3.0 standard, with transmission speeds of up to 4.8 Giga-Byte/second. Of course, they are also compatible with the previous USB 1.1 and 2.0 protocols. All plastic materials are safe, and comply with the UL94 standard. Lengths range from 1m to 5m are available, and offer the main types of connectors used in the music and ProAudio fields.

- Transferring speed reaches 4.8GB/sec. (10 times of that of USB 2.0)
- USB 2.0 and USB1.1 compatible
- Power saving, quicker recharging for auto-recharge devices
- USB 3.0 30micron plating
- Plastic parts meet the requirement of UL94V-0

WM-USB300 (USB-A M a USB-A M)

J510J	WM-USB300-10	1 mt	€6,45	£5.92
J511J	WM-USB300-20	2 mt	€7,72	£7.09
J512J	WM-USB300-30	3 mt	€9,19	£8.44
J513J	WM-USB300-50	5 mt	€11,96	£10.98

WM-USB310 (USB-A M a USB-B 3.0 M)

J514J	WM-USB310-10	1 mt	€7,96	£7.31
J515J	WM-USB310-20	2 mt	€9,12	£8.37
J516J	WM-USB310-30	3 mt	€10,41	£9.56
J517J	WM-USB310-50	5 mt	€13,33	£12.24



WM-USB320 (USB-A M a USB-C M)

J518J	WM-USB320-10	1 mt	€6,77	£6.21
J519J	WM-USB320-20	2 mt	€8,10	£7.44
J520J	WM-USB320-30	3 mt	€9,65	£8.86
J521J	WM-USB320-50	5 mt	€12,42	£11.40



Available in different versions/length, Soundsation GO-LINK USB cables are the perfect choice for connecting your devices/interfaces and for facing an ever growing set of applications.

U120-15

- USB-A/USB-A cable (1,5 mt)

CODE	MSRPEUR	MSRP GBP
I265I	€3,61	£3.31

U120-30

- USB-A/USB-A cable (3 mt)

CODE	MSRPEUR	MSRP GBP
I266I	€4,95	£4.54



soundSation Wiremaster Series



Premium Quality Cables

SoundSation Wiremaster series is a professional line of microphone, instrument, power and patch cables featuring REAN and YONGSHENG by NEUTRIK premium quality connectors and Oxygen Free Copper construction. Conceived to provide users with high performance products and built with selected materials, Wiremaster series means superior quality construction and shielding, fully preserved tone and unmatched durability.

GO-Link

SoundSation GO-LINK series is a professional line of assembled cables born to provide full reliability for a wide range of applications. Built in Oxygen Free Copper, the GO-LINK series means quality construction, effective shielding, preserved tone and rugged durability. Available for instruments, microphones, speakers, GO-LINKS series also includes cables for data transmission and digital applications. Oxygen-Free Copper (O.F.C.) conductors

BMD-1BK



- 5 pin DIN - 5 pin DIN
- Designed to connect MIDI devices
- Nickel-plated plugs ensure durability and efficient signal transfer
- Length: 1 mt

CODE	MSRP EUR	MSRP GBP
H483H	€4,04	£3.71

BMD-2BK



- 5 pin DIN - 5 pin DIN
- Designed to connect MIDI devices
- Nickel-plated plugs ensure durability and efficient signal transfer
- Length: 2 mt

CODE	MSRP EUR	MSRP GBP
H484H	€5,06	£4.65

BMD-3BK



- 5 pin DIN - 5 pin DIN
- Designed to connect MIDI devices
- Nickel-plated plugs ensure durability and efficient signal transfer
- Length: 3 mt

CODE	MSRP EUR	MSRP GBP
H485H	€5,95	£5.46

BMD-5BK



- 5 pin DIN - 5 pin DIN
- Designed to connect MIDI devices
- Nickel-plated plugs ensure durability and efficient signal transfer
- Length: 5 mt

CODE	MSRP EUR	MSRP GBP
H486H	€8,13	£7.46

BDCXX-10BK - AES/EBU&DMX cable

- 100% shielded
- Conductors: 2x0.34mm²
- Diameter: 6.5mm
- Length: 10mt
- Applications: digital connections and DMX

CODE	MSRP EUR	MSRP GBP
I249I	€16,68	£15.31





Soundsation GO-LINK series is a professional line of assembled cables born to provide full reliability for a wide range of applications. Built in Oxygen Free Copper, the GO-LINK series means quality construction, effective shielding, preserved tone and rugged durability. Available for instruments, microphones, speakers, GO-LINKS series also includes cables for data transmission and digital applications.

DCR2034-100 - Bulk AES/EBU - DMX cable (100 mt)

- AES/EBU - DMX cable
- OFC construction (Oxygen Free Copper)
- High conductivity
- Shielding: 100% with spiral copper 80x0,10 mm + AL/PT foil + PE filter
- Inner conductors: 2x0,34 mm2
- Copper strand per conductors: 7x0,25 mm
- Diameter: 6,5 mm
- Jacket: PVC
- Temp. range: -20(min)/70 (max)
- AWG: 24
- Capac. cond/cond per 1 m: <65pF
- Capac. cond/shield per 1 m: 115pF
- Cond. resistance per 1 km: 53 Ohm
- Shield resistance per 1 km: 17 Ohm
- Insulation resist. per 1 km: >10G Ohm
- Surge impedance: 110 Ohm

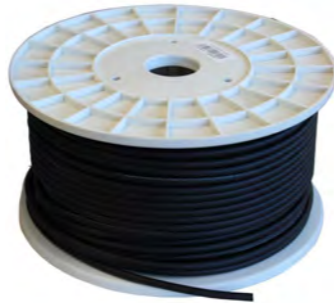

CODE	MSRP EUR	MSRP GBP
I248I	€144,95	£133.06

GO-LINK FAC100B - Flat Audio cable reel (100mt)

- Wire diameter 2x1x0.14 mm² and fine wire stranding for hi quality transmission
- Cable diameter: 4.0mmx8.0mm
- Copper spiral shielding (90%) for noiseless performances
- Every conductor is insulated and individually shielded
- Individual stranding ensures flexibility



CODE	MSRP EUR	MSRP GBP
R321R	€88,68	£81.41

GL-FHIFI100T - Flat Hi-Fi speaker cable reel (100mt)

- Wire diameter 2x1.5 mm² for hi quality transmission
- Cable diameter: 3.5mmx7.0mm
- Flexible
- Application: multipurpose connections in dry and indoor environments



CODE	MSRP EUR	MSRP GBP
R322R	€192,13	£176.38

ICR1022-100 - Bulk instrument cable (100 mt)

- OFC construction (Oxygen Free Copper)
- High conductivity
- Shielding: 100% with spiral copper 48x0,10 mm
- Inner conductors: 1x0,22 mm2
- Copper strand per conductors: 28x0,10 mm
- Diameter: 6 mm
- Jacket: PVC
- Temp. range: -20(min)/70 (max)
- AWG: 24
- Capac. cond/cond per 1 m: 85pF
- Capac. cond/shield per 1 m: 85pF
- Cond. resistance per 1 km: 90 Ohm
- Insulation resist. per 1 km: >1G Ohm



CODE	MSRP EUR	MSRP GBP
I245I	€88,64	£81.37

MCR2022-100 - Bulk balanced microphonic cable (100 mt)

- OFC construction (Oxygen Free Copper)
- High conductivity
- Shielding: 95% with spiral copper 80x0,10 mm
- Inner conductors: 2x0,22 mm2
- Copper strand per conductors: 28x0,10 mm
- Diameter: 6 mm
- Jacket: PVC
- Temp. range: -20(min)/70 (max)
- AWG: 24
- Capac. cond/cond per 1 m: 68pF
- Capac. cond/shield per 1 m: 130pF
- Cond. resistance per 1 km: 53 Ohm
- Shield resistance per 1 km: 25 Ohm
- Insulation resist. per 1 km: >1G Ohm
- Surge impedance: approx 100 Ohm



CODE	MSRP EUR	MSRP GBP
I244I	€119,79	£109.97

SCR215-100 - Bulk speaker cable (100 mt)

- Passive speaker cable
- OFC construction (Oxygen Free Copper)
- High conductivity
- Inner conductors: 2x1,5 mm2
- Copper strand per conductors: 48x0,20 mm
- Diameter: 7 mm
- Jacket: PVC
- Temp. range: -20(min)/70 (max)
- AWG: 16
- Insulation resist. per 1 km: >1G Ohm

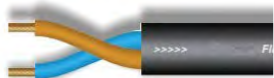

CODE	MSRP EUR	MSRP GBP
I246I	€232,03	£213.00

SCR220-100 - Bulk speaker cable (100 mt)

- Passive speaker cable OFC construction (Oxygen Free Copper)
- High conductivity
- Inner conductors: 2x2,0 mm2
- Copper strand per conductors: 64x0,20 mm
- Diameter: 7,5 mm
- Jacket: PVC
- Temp. range: -20(min)/70 (max)
- AWG: 14

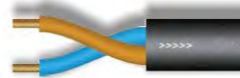

CODE	MSRP EUR	MSRP GBP
I247I	€292,28	£268.31



WM-BC100B - Wiremaster balanced microphone cable reel (100mt)

- Professional balanced microphone cable (100 mt)
- Large wire diameter of 2x0.30 mm² for high transmission quality
- Cable diameter: 6.5mm
- Dense copper braided shielding (95%) for noiseless performances
- PE insulation grants very low capacity
- Flexible, easy winding
- Application: stage, mobile, studio, installations
- Shielding: 95% copper



CODE	MSRP EUR	MSRP GBP
R318R	€186,05	£170.79

WM-SC100B - Wiremaster speaker cable reel (2x2.5 mm² - 100mt)

- Professional speaker cable (100 mt)
- Large wire diameter of 2x2.5 mm² for high transmission quality
- Cable diameter: 8.0mm
- Noiseless performances
- Flexible, easy winding
- Application: sound systems, installations
- Cable reel length: 100mt



CODE	MSRP EUR	MSRP GBP
R320R	€348,69	£320.10

WM-SC144B - Wiremaster speaker cable reel (4x4 mm² - 100mt)

- Professional speaker cable (100 mt)
- Large wire diameter of 4x4 mm² for high transmission quality
- Cable diameter: 13.2mm
- Noiseless performances and zero signal loss due to special stranding
- Flexible, easy winding
- Application: professional sound systems/PA, installations, surround and woofer systems



CODE	MSRP EUR	MSRP GBP
R510R	€895,69	£822.24

CB-CAT5 - Assembled CAT5 cable drum system

- Assembled CAT5e cable + RJ45 connector w/ABS drum system
- O.F.C. construction
- Large wire diameter of 4x2x0.20 mm² for high transmission quality
- Cable diameter: 6.4mm
- Very robust TPU jacket

- Tin copper braided shielding (95%) for noiseless performances
- Halogen free and flame retardant
- Flexible, easy winding
- Ethersound transmission up to 110m
- Application: network connections, data system technology



CODE	MODEL	LENGHT	MSRP EUR	MSRP GBP
J038J	CB-CAT5-50	50 mt	€213,61	£196.09
J039J	CB-CAT5-70	70 mt	€272,73	£250.37

WM-IC100B - Wiremaster unbalanced instrument cable reel (100mt)

- Professional unbalanced instrument cable (100 mt)
- Special stranding and a wire diameter of 0.50 mm² provides outstanding sound image for instruments
- Cable diameter: 7.0mm
- Combination of copper braided shield and semiconductor shielding for effective double shielding
- Flexible, easy winding
- Application: studio and stage, connection of stereo video recorder and DAT-recorder



CODE	MSRP EUR	MSRP GBP
R319R	€178,79	£164.13

WM-SC140B - Wiremaster speaker cable reel (4x2.5 mm² - 100mt)

- Professional speaker cable (100 mt)
- Large wire diameter of 4x2.5 mm² for high transmission quality
- Cable diameter: 11mm
- Noiseless performances
- Flexible, easy winding
- Application: sound systems, installations



CODE	MSRP EUR	MSRP GBP
R509R	€603,21	£553.75

WM-SC124B - Wiremaster speaker cable reel (2x4 mm² - 100mt)

- Professional Speaker cable (100 mt)
- Large wire diameter of 2x4 mm²
- Cable diameter: 11mm
- Noiseless performances
- Flexible, easy winding
- Application: sound systems, hi-fi systems, installations



CODE	MSRP EUR	MSRP GBP
E086E	€541,43	£497.03

Wiremaster
Series

WM-BC215G

- Professional Speaker cable (100 mt)
- O.F.C. construction
- Large wire diameter of 2x1,5 mm²
- Noiseless performances
- High quality jacket PVC ensures unmatched durability
- Flexible, easy winding
- Application: sound systems, hi-fi systems, installations

CODE	MSRP EUR	MSRP GBP
J390J	€196,33	£180.23



WM-BC240G

- Professional Speaker cable (100 mt)
- O.F.C. construction
- Large wire diameter of 2x4,0 mm²
- Noiseless performances
- High quality jacket PVC ensures unmatched durability
- Flexible, easy winding
- Application: sound systems, hi-fi systems, installations

CODE	MSRP EUR	MSRP GBP
J391J	€448,76	£411.96



WM-SC225G

- Professional Speaker cable (100 mt)
- O.F.C. construction
- Large wire diameter of 2x2,5 mm²
- Noiseless performances
- High quality jacket PVC ensures unmatched durability
- Flexible, easy winding
- Application: sound systems, hi-fi systems, installations

CODE	MSRP EUR	MSRP GBP
J392J	€293,19	£269.15



WM-MC203B

- Professional balanced microphone cable (100 mt)
- O.F.C. construction
- Large wire diameter of 2x0.30 mm² for high transmission quality
- Cable diameter: 6.3 mm
- Dense copper spiral shielding (95%) for noiseless performances
- PE insulation grants very low capacity
- Flexible, easy winding
- Application: stage, mobile, studio, installations

CODE	MSRP EUR	MSRP GBP
J393J	€125,88	£115.56



WM-PCS-15 - Power cable featuring 3P EC standard (VDE) - Shuko plug



- 3P EC standard (VDE) - Shuko plug
- Conductors: 3x1mmq
- Length: 1.5 meters

CODE	MSRP EUR	MSRP GBP
E442E	€6,51	£5.98

WM-PCI-15 - Power cable featuring 3P EC standard (VDE) - Italian plug



- 3P EC standard (VDE) - Italian plug
- Conductors: 3x1mmq
- Length: 1.5 meters

CODE	MSRP EUR	MSRP GBP
E443E	€6,51	£5.98

WM-PCAS-15 - Power cable featuring Powercon A - Italian plug



- Powercon A - Italian plug
- Conductors: 3x1.5mmq
- Length: 1.5 meters

CODE	MSRP EUR	MSRP GBP
E444E	€10,25	£9.41

WM-PCBA-15 - Power cable featuring Powercon A - Powercon B



- Powercon A - Powercon B
- Conductors: 3x2.5mmq
- Length: 1.5 meters

CODE	MSRP EUR	MSRP GBP
E445E	€13,28	£12.19

WM-PCIPS-15 - Power cable featuring IP65 powercon female - Shuko plug



- IP65 powercon female - Shuko plug
- Conductors: 3x2.5mmq
- Length: 1.5 meters

CODE	MSRP EUR	MSRP GBP
E448E	€17,39	£15.96

Wiremaster
Series

Adapter

Conceived to provide users with professional solutions for a wide range of applications, Soundsation WIREMASTER adapters mean reliability, fully preserved tone and noiseless performances thanks to hand soldered connections and internal wiring moulded with resin. Color: black and grey **1 pc blister**

WM-A200



- 1x3.5 Angled Stereo male - 1x3.5 Stereo female

CODE	MSRP EUR	MSRP GBP
R312R	€1,53	£1.40

WM-A220



- 1x3.5 Stereo male - 1x6.3 Stereo female

CODE	MSRP EUR	MSRP GBP
R313R	€2,28	£2.09

WM-A240



- 1x6.3 Stereo male - 1x3.5 Stereo female

CODE	MSRP EUR	MSRP GBP
R314R	€1,94	£1.78

WM-A260



- 1x6.3 Stereo male - 1xRCA female

CODE	MSRP EUR	MSRP GBP
R315R	€1,57	£1.44

WM-A280



- 1x6.3 Angled Stereo male - 1x6.3 Stereo female

CODE	MSRP EUR	MSRP GBP
R316R	€2,77	£2.54

WM-A285



- 1x6.3 Stereo female - 1x6.3 Stereo female

CODE	MSRP EUR	MSRP GBP
R317R	€3,78	£3.47

WM-A300



- 1x6.3 Stereo male - 2x6.3 Stereo female

CODE	MSRP EUR	MSRP GBP
R305R	€4,79	£4.40

WM-A310



- 1xRCA male - 1xRCA female

CODE	MSRP EUR	MSRP GBP
R309R	€1,65	£1.51

WM-A320



- 1x3.5 Stereo male - 2x6.3 Stereo female

CODE	MSRP EUR	MSRP GBP
R306R	€4,00	£3.67

WM-A330



- 1x6.3 Stereo male - 2xRCA female

CODE	MSRP EUR	MSRP GBP
R310R	€2,21	£2.03

WM-A340



- 1x6.3 Stereo male - 2x3.5 Stereo female

CODE	MSRP EUR	MSRP GBP
R307R	€2,77	£2.54

WM-A350



- 1x3.5 Stereo male - 2x6.3 RCA female

CODE	MSRP EUR	MSRP GBP
R311R	€1,65	£1.51

WM-A360



- 1x3.5 Stereo maschio - 2x3.5 Stereo femmina

CODE	MSRP EUR	MSRP GBP
R308R	€2,21	£2.03

WM-S4PFJF



- Professional 4P Speakon female - 6.3mm Jack MONO female adapter

CODE	MSRP EUR	MSRP GBP
R434R	€7,11	£6.53

WM-S4PFXF



- Professional 4P Speakon female - 3P XLR female adapter

CODE	MSRP EUR	MSRP GBP
R437R	€7,11	£6.53

WM-S4PMJF



- Professional 4P Speakon female - 6.3mm Jack MONO adapter

CODE	MSRP EUR	MSRP GBP
R435R	€7,11	£6.53

WM-S4PFXM



- Professional 4P Speakon female - 3P XLR male adapter

CODE	MSRP EUR	MSRP GBP
R436R	€7,11	£6.53

WM-S4PMS4PM



- Professional 4P Speakon male - 4P Speakon male

CODE	MSRP EUR	MSRP GBP
R440R	€7,33	£6.73

WM-S4PMXF



- Professional 4P Speakon male - 3P XLR female adapter

CODE	MSRP EUR	MSRP GBP
R438R	€7,11	£6.53

WM-S4PMXM



- Professional 4P Speakon male - 3P Speakon male adapter

CODE	MSRP EUR	MSRP GBP
R439R	€7,11	£6.53

Wiremaster
Series

Adapter

GO-Link

Adapter

WM-SACPOWER-IN



- Professional 3 pole AC Powercon mount connector
- Cable strain relief
- 20A/250V AC
- Power-IN (blue)
- 1 pc blister

CODE	MSRP EUR	MSRP GBP
R441R	€3,59	£3.30

WM-SACPOWER-OUT



- Professional 3 pole AC Powercon mount connector
- Cable strain relief
- 20A/250V AC
- Power-OUT (grey)
- 1 pc blister

CODE	MSRP EUR	MSRP GBP
E085E	€3,59	£3.30

WM-FX3



- True mains connector IP-65 (female)
- Lockable with twist lock system
- Dust and water resistant (IP 65)

CODE	MSRP EUR	MSRP GBP
E249E	€7,48	£6.87

WM-MX3



- True mains connector IP-65 (maschio)
- Lockable with twist lock system
- Dust and water resistant (IP 65)

CODE	MSRP EUR	MSRP GBP
E250E	€7,14	£6.55

WM-A-4M4M



- 4P M receptable/4P M receptable adapter

CODE	MSRP EUR	MSRP GBP
E439E	€6,73	£6.18

SADA010-1



- XLR Female - 6.3mm Jack Female

CODE	MSRP EUR	MSRP GBP
I762I	€2,92	£2.68

SADA011-1



- XLR Male - RCA Male

CODE	MSRP EUR	MSRP GBP
I763I	€2,68	£2.46

SADA012-1



- XLR Female - RCA Male

CODE	MSRP EUR	MSRP GBP
I764I	€2,88	£2.64

SADA013-1



- XLR Male - RCA Female

CODE	MSRP EUR	MSRP GBP
I765I	€2,64	£2.42

SADA028-1

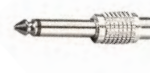

- 6.3mm jack Male - RCA Female

CODE	MSRP EUR	MSRP GBP
I769I	€1,56	£1.43

SADA031-1



- 6.3mm Jack Male MONO - 6.3mm Jack Female

CODE	MSRP EUR	MSRP GBP
I770I	€1,01	£0.93

SADA032-1



- 6.3mm Jack Female - 6.3mm Jack Male STEREO

CODE	MSRP EUR	MSRP GBP
I771I	€1,01	£0.93

SADA033-1



- 6.3mm Jack Male MONO - 3.5mm Jack Female

CODE	MSRP EUR	MSRP GBP
I772I	€1,05	£0.96

SADA034-1



- 3.5mm Jack Female - 6.3mm Jack Male STEREO

CODE	MSRP EUR	MSRP GBP
I773I	€1,01	£0.93

SADA035-1



- 3.5mm Jack Male MONO - 6.3mm Jack Female

CODE	MSRP EUR	MSRP GBP
I774I	€0,97	£0.89

SADA04-1



- XLR Female - 6.3mm Jack Female

CODE	MSRP EUR	MSRP GBP
I756I	€3,54	£3.25

SADA049-1



- Poles: 5F-3M

CODE	MSRP EUR	MSRP GBP
I768I	€3,27	£3.00

SADA05-1



- XLR Male - 6.3mm Jack Female

CODE	MSRP EUR	MSRP GBP
I757I	€3,38	£3.10

SADA050-1



- Poles: 3F-5M
- DMX adapter

CODE	MSRP EUR	MSRP GBP
I767I	€3,07	£2.82

SADA051-1



- XLR Female - 6.3mm Jack Female

CODE	MSRP EUR	MSRP GBP
I766I	€2,80	£2.57

SADA06-1



- XLR Female - 6.3mm Jack Male

CODE	MSRP EUR	MSRP GBP
I758I	€3,27	£3.00

SADA07-1



- XLR Male - 6.3mm Jack Male MONO

CODE	MSRP EUR	MSRP GBP
I759I	€3,07	£2.82

SADA08-1



- XLR Female - 6.3mm Jack Male STEREO (balanced)

CODE	MSRP EUR	MSRP GBP
I760I	€3,50	£3.21

SADA09-1



- XLR Male - 6.3mm Jack Male STEREO (balanced)

CODE	MSRP EUR	MSRP GBP
I761I	€3,27	£3.00

SADA036-1



- 3.5mm Jack Male STEREO - 6.3mm Jack Female STEREO

CODE	MSRP EUR	MSRP GBP
I775I	€1,09	£1.00



Adapter

SADA99-1



- 3.5mm Jack Male STEREO - 2.5mm Jack Female STEREO

CODE	MSRP EUR	MSRP GBP
R626R	€1,75	£1.61

SADA101-1



- 2xRCA femmina - 2xRCA femmina
- Costruito in metallo

CODE	MSRP EUR	MSRP GBP
E821E	€0,58	£0.53

SADA100-1



- RCA femmina - RCA femmina
- Costruito in metallo

CODE	MSRP EUR	MSRP GBP
E822E	€0,74	£0.68

SADA047



- 3,5mm jack Male stereo - 2 x 6,3mm Jack Female

CODE	MSRP EUR	MSRP GBP
L121L	€3,68	£3.38

SADA038-1



- 2.5mm Jack Male STEREO - 3.5mm Jack Female STEREO

CODE	MSRP EUR	MSRP GBP
I776I	€1,13	£1.04

SADA039-1



- 6.3mm Jack Male MONO - 2x6.3mm Jack Female

CODE	MSRP EUR	MSRP GBP
I777I	€1,44	£1.32

SADA040-1



- 6.3mm Jack Male STEREO - 2x6.3mm Jack Female STEREO

CODE	MSRP EUR	MSRP GBP
I778I	€1,24	£1.14

SADA041-1



- 3.5mm Jack Male MONO - 2x3.5mm Jack Female

CODE	MSRP EUR	MSRP GBP
I779I	€0,82	£0.75

SADA043-1



- 2xRCA Female - 3.5mm Jack Male MONO

CODE	MSRP EUR	MSRP GBP
I783I	€1,09	£1.00

SADA044-1



- 2xRCA Female - 3.5mm Jack Male STEREO

CODE	MSRP EUR	MSRP GBP
I784I	€1,01	£0.93

SADA045-1



- 2xRCA Female - RCA Female

CODE	MSRP EUR	MSRP GBP
I785I	€1,09	£1.00

SADA046-1



- 2xRCA Female - RCA Male

CODE	MSRP EUR	MSRP GBP
I786I	€1,01	£0.93

SADA042-1



- 3.5mm Jack Male STEREO - 2x6.3mm Jack Female STEREO

CODE	MSRP EUR	MSRP GBP
I781I	€1,24	£1.14

SXLR034F - Satin finish metal angled connector (XLR 3 pole female - 4pcs)

- Package: 4 pcs
- Satin finish metal



CODE	MSRP EUR	MSRP GBP
L081L	€1,00	£0.92

SADA031 - 6,3mm jack Male - 6,3mm jack Female adapter (4 pcs set)

- 6,3mm jack Male - 6,3mm jack Female
- Metal construction
- Set: 4 pcs



CODE	MSRP EUR	MSRP GBP
L106L	€3,47	£3.19



Adapter

SADA048-1



- 2xRCA Female - 6.3mm Jack Male MONO

CODE	MSRP EUR	MSRP GBP
I787I	€1,40	£1.29

SRCA028F



- Package: 4 pcs

CODE	MSRP EUR	MSRP GBP
L090L	€8,89	£8.16

SRCA030F



- Package: 25 pcs

CODE	MSRP EUR	MSRP GBP
L094L	€8,48	£7.78



Connectors

WM-CX-5F



- Professional 5 pole XLR cable mount female plug

CODE	MSRP EUR	MSRP GBP
E433E	€2,47	£2.27

WM-CX-5M



- Professional 5 pole XLR cable mount male plug

CODE	MSRP EUR	MSRP GBP
E434E	€2,43	£2.23

WM-PMX-3F



- Professional 3 pole XLR panel mount female receptacle

CODE	MSRP EUR	MSRP GBP
E435E	€1,35	£1.24

WM-PMX-3M



- Professional 3 pole XLR panel mount male receptacle

CODE	MSRP EUR	MSRP GBP
E436E	€1,35	£1.24

WM-PMS-4M



- Professional 4 poli speaker panel mount male receptacle

CODE	MSRP EUR	MSRP GBP
E437E	€1,50	£1.38

WM-PMS-8M



- Professional 8 poli speaker panel mount male receptacle

CODE	MSRP EUR	MSRP GBP
E438E	€3,29	£3.02

WM-AC3P-IN

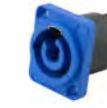

- 3 pole AC Power-In receptable (blue)

CODE	MSRP EUR	MSRP GBP
E440E	€1,93	£1.77

WM-AC3P-OUT



- 3 pole AC Power-Out receptable (grey)

CODE	MSRP EUR	MSRP GBP
E441E	€1,93	£1.77

Pack Connettori
 Package: 25 pcs
SSPK01F-B

■ 8 pole Speakon female

CODE	MSRP EUR	MSRP GBP
I744I	€108,76	£99.84

SSPK05F-B

■ 4 pole Speakon female

CODE	MSRP EUR	MSRP GBP
I748I	€69,23	£63.55

SSPK03M-B

■ 4 pole Speakon male

CODE	MSRP EUR	MSRP GBP
I746I	€38,00	£34.88

SSPK02F-B

■ 4 pole Speakon female

CODE	MSRP EUR	MSRP GBP
I745I	€35,16	£32.28

SSPK04F-B

■ 4 pole Speakon female

CODE	MSRP EUR	MSRP GBP
I747I	€34,35	£31.53

SXLR034F-B

■ Metal angled connector XLR 3P female (25 pcs box)

CODE	MSRP EUR	MSRP GBP
I742I	€91,51	£84.01

SXLR034M-B

■ Metal angled connector XLR 3P male (25 pcs box)

CODE	MSRP EUR	MSRP GBP
I743I	€91,51	£84.01

SXLR025F-B

■ Metal connector XLR 3P female (25 pcs box)

CODE	MSRP EUR	MSRP GBP
I740I	€40,25	£36.95

SXLR025M-B

■ Metal connector XLR 3P male (25 pcs box)

CODE	MSRP EUR	MSRP GBP
I741I	€39,36	£36.13

SXLR01F-B

■ Metal connector XLR 3P female (25 pcs box)

CODE	MSRP EUR	MSRP GBP
I736I	€37,61	£34.53

SXLR01M-B

■ Metal connector XLR 3P male (25 pcs box)

CODE	MSRP EUR	MSRP GBP
I737I	€36,64	£33.64

SXLR04F-B

■ Metal connector XLR 3P female (25 pcs box)

CODE	MSRP EUR	MSRP GBP
I738I	€30,49	£27.99

SXLR04M-B

■ Metal connector XLR 3P male (25 pcs box)

CODE	MSRP EUR	MSRP GBP
I739I	€28,16	£25.85

SRCA030F-B

■ RCA female (satin)

CODE	MSRP EUR	MSRP GBP
I755I	€51,72	£47.48

SRCA029F-B

■ RCA femmina (black)

CODE	MSRP EUR	MSRP GBP
I753I	€63,90	£58.66

SRCA028F-B

■ RCA female (satin)

CODE	MSRP EUR	MSRP GBP
I751I	€63,90	£58.66

SRCA026M-B

■ RCA male (satin)

CODE	MSRP EUR	MSRP GBP
I750I	€63,04	£57.87

Pack Connettori
 Package: 25 pcs
SRCA023M-B

■ RCA male (satin)

CODE	MSRP EUR	MSRP GBP
I754I	€63,90	£58.66

SRCA01M-B

■ RCA male (gold)

CODE	MSRP EUR	MSRP GBP
I749I	€54,88	£50.38

SRCA018M-B

■ RCA male (black)

CODE	MSRP EUR	MSRP GBP
I752I	€63,90	£58.66

SJ011M-B

■ 6.3mm jack MONO

CODE	MSRP EUR	MSRP GBP
I726I	€25,47	£23.38

SJ011S-B

■ 6.3mm jack STEREO

CODE	MSRP EUR	MSRP GBP
I727I	€30,49	£27.99

SJ024M-B

■ 6.3mm jack MONO

CODE	MSRP EUR	MSRP GBP
I728I	€31,81	£29.20

SJ024S-B

■ 6.3mm jack STEREO

CODE	MSRP EUR	MSRP GBP
I729I	€33,02	£30.31

SJ029M-B

■ 6.3mm jack MONO 90° angled

CODE	MSRP EUR	MSRP GBP
I730I	€37,03	£33.99

SJ029S-B

■ 6.3mm jack STEREO 90° angled

CODE	MSRP EUR	MSRP GBP
I731I	€42,63	£39.13

SJ02M-B

■ 6.3mm jack MONO gold tip

CODE	MSRP EUR	MSRP GBP
I722I	€31,39	£28.82

SJ02S-B

■ 6.3mm jack STEREO gold tip

CODE	MSRP EUR	MSRP GBP
I723I	€35,04	£32.17

SJ033M-B

■ 6.3mm jack MONO 90° angled with gold tip

CODE	MSRP EUR	MSRP GBP
I732I	€40,84	£37.49

SJ033S-B

■ 6.3mm jack STEREO 90° angled with gold tip

CODE	MSRP EUR	MSRP GBP
I733I	€42,78	£39.27

SJ037M-B

■ 3.5mm jack MONO 90°

CODE	MSRP EUR	MSRP GBP
I734I	€14,78	£13.57

SJ037S-B

■ 3.5mm jack STEREO

CODE	MSRP EUR	MSRP GBP
I735I	€19,45	£17.86

SJ06M-B

■ 6.3mm jack MONO gold tip

CODE	MSRP EUR	MSRP GBP
I724I	€31,78	£29.17



SJ06S-B



- 6.3mm jack STEREO gold tip

CODE	MSRP EUR	MSRP GBP
I725I	€35,39	£32.49

GL-SJSPEAKER



- 6.3mm Jack MONO male connector

CODE	MSRP EUR	MSRP GBP
R433R	€48,69	£44.70

NAC3FCA



- Quick lock with securing lever

CODE	MSRP EUR	MSRP GBP
L647L	€19,60	£17.99

Pack Connettori
Package: 25 pcs



YS176L-BG - Connettore Yongsheng by Neutrik® XLR 3P-F (scatola 25 pz)



- Connettore professionale Yongsheng by Neutrik® XLR 3 poli femmina
- In lega di zinco brunito
- Cappuccio in plastica
- Sistema fermacavo in PVC con guida
- Contatti dorati

CODE	MSRP EUR	MSRP GBP
E864E	€70,90	£65.09

YS177L-BG - Connettore Yongsheng by Neutrik® XLR 3P-M (scatola 25 pz)



- Connettore professionale Yongsheng by Neutrik® XLR 3 poli maschio
- In lega di zinco brunito
- Cappuccio in plastica
- Sistema fermacavo in PVC con guida
- Contatti dorati

CODE	MSRP EUR	MSRP GBP
E865E	€69,90	£64.17



Wiremaster series features REAN/Yongsheng by Neutrik® connectors, products conceived to provide hi quality performances for a wide range of professional applications. - **25 pcs box**

Y207E-BG



- Yongsheng by Neutrik® professional 6.3mm Mono Male right angle Jack plug
- Black plated Zinc-alloy shell
- Gold contacts

CODE	MSRP EUR	MSRP GBP
R427R	€67,06	£61.56

Y208E-BG



- Yongsheng by Neutrik® 6.3mm Jack STEREO right angle connector (25 pcs box)
- Black plated Zinc-alloy shell
- Cable clamping system
- Gold contacts

CODE	MSRP EUR	MSRP GBP
R428R	€81,39	£74.72

Y224E-BG



- Yongsheng by Neutrik® 6.3mm Jack MONO male connector (25 pcs box)
- Black plated Zinc-alloy shell
- Cable clamping system
- Gold contacts

CODE	MSRP EUR	MSRP GBP
R425R	€80,42	£73.83

Y228E-BG



- Yongsheng by Neutrik® 6.3mm Jack STEREO male connector (25 pcs box)
- Black plated Zinc-alloy shell
- Cable clamping system
- Gold contacts

CODE	MSRP EUR	MSRP GBP
R426R	€108,13	£99.26

YS373-BG



- Yongsheng by Neutrik® RCA male (26 pcs box)
- Black plated Brass shell with red and black rings
- Cable spring
- Gold contacts

CODE	MSRP EUR	MSRP GBP
R430R	€101,53	£93.20

YS2203P-B



- Yongsheng by Neutrik® 6.3mm MONO male/STEREO female connector (25 pcs box)
- Nickel plated brass shell
- Cable clamping system
- Silver contacts

CODE	MSRP EUR	MSRP GBP
R431R	€176,31	£161.85

YS240L-BG



- Yongsheng by Neutrik® 3.5mm Jack MONO male/STEREO female connector (25 pcs box)
- Nickel plated brass shell
- Cable clamping system
- Silver contacts

CODE	MSRP EUR	MSRP GBP
R432R	€62,25	£57.15

YS231L-BG



- Yongsheng by Neutrik® 3.5mm Jack STEREO male connector (25 pcs box)
- Black plated Zinc-alloy shell
- Cable clamping system
- Gold contacts

CODE	MSRP EUR	MSRP GBP
R429R	€47,07	£43.21

SCT100 - Universal cable tester

Compact and light, a truly universal cable tester perfect for checking your cables and connectors anytime, anywhere.

- USB
- Speakon (4/8 pole)
- Jack 6,3"/3,5"
- XLR
- RCA
- MIDI
- S-video
- RJ-45
- Din (8 pole)



CODE	MSRP EUR	MSRP GBP
N324N	€56,91	£52.24

WM-STRAP02



- Velcro for safe and quick use
- Dimensions: 170mmx20mm

CODE	MSRP EUR	MSRP GBP
R442R	€0,26	£0.24

WM-STRAP04



- Velcro for safe and quick use
- Dimensions: 270mmx25mm

CODE	MSRP EUR	MSRP GBP
R443R	€0,34	£0.31

CABLE ACCESSORIES

PSU-40 is a compact primary switched power supply with environmental-friendly design. The high-efficiency design is aimed at conserving energy. The unit is universal since it can convert power into any of the 3/4.5/5/6/7.5/9/12V DC outputs. It incorporates Short Circuit Protection and Automatic Overload Cutoff safety features.

PSU-40 - Switching multitension PSU (1500mA)

- convert to DC Power 3/4.5/5/6/7.5/9/12V
- EuP compliant / ErP 3nd stage compliant
- Short Circuit Protection
- Automatic Overload Cutoff

- Input Voltage : 100-240V AC 50-60HZ Output 1500mA
- Output voltage : DC Power 3.0/4.5/5.0/6.0/7.5/9.0/12V DC
- Power LED indicator
- 6 different plug type
- Dimension : 82.0 mm(L) x 51.6 mm(W) x 35.9mm(H)
- Net weight: 130g



CODE	MSRP EUR	MSRP GBP
J563J	£15.50	€16,88

PSU-50 - Switching multitension PSU (2250mA)

- convert to DC Power 3/4.5/5/6/7.5/9/12V
- EuP compliant / ErP 3nd stage compliant
- Short Circuit Protection
- Automatic Overload Cutoff

- Input Voltage : 100-240V AC 50-60HZ Output 2250mA
- Output voltage : DC Power 3.0/4.5/5.0/6.0/7.5/9.0/12V DC
- Power LED indicator
- 6 different plug type
- Dimension : 87.50 x 51.00 x 40,01 mm
- Net weight: 200g



CODE	MSRP EUR	MSRP GBP
J564J	£20.47	€22,30

PSU-60 - Switching multitension PSU (3000mA)

- Convert to DC Power 3/4.5/5/6/7.5/9/12V
- EuP compliant / ErP 3nd stage compliant
- Short Circuit Protection
- Automatic Overload Cutoff

- Input Voltage : 100-240V AC 50-60HZ Output 2250mA
- Output voltage : DC Power 3.0/4.5/5.0/6.0/7.5/9.0/12V DC
- Power LED indicator
- 6 different plug type
- Dimensions : 115.5 mm(L) x 50.0 mm(W) x 32.0 mm(H)
- Net weight: 310 gr



CODE	MSRP EUR	MSRP GBP
J565J	€30,52	£28.02



CASES

CA-1 - Microphone Flight case

Rugged and comfortable flight case for storage and transportation of microphones and accessories. Internal foam layer absorb eventual unwanted shocks. Perfect also for effect pedals, half-rack electronic modules, cables.



√ Dimensions (D x L x H): 280x380x100 cm

CODE	MSRP EUR	MSRP GBP
M347M	€40,35	£37.04

CA-2 - Microphone Flight case

Rugged and comfortable flight case for storage and transportation of wireless microphones and accessories. Internal foam layer absorb eventual unwanted shocks. Perfect also for MI effect pedal boards, rack 1U electronic modules, cables.



√ Dimensions (D x L x H): 295x560x85 cm

CODE	MSRP EUR	MSRP GBP
M348M	€64,51	£59.22

CA-3 - Microphone Flight case

Rugged and comfortable flight case for storage and transportation of microphones and accessories. Internal foam layer absorb eventual unwanted shocks. Perfect also for audio interfaces, cables.

√ Dimensions (D x L x H): 250x320x150 cm

CODE	MSRP EUR	MSRP GBP
M349M	€40,43	£37.11

**BG-600D - Bag in resistant nylon cloth for 2 speaker stands**

BG-600D is a sturdy bag made of nylon cloth capable of holding two speaker stands(not included). The bag is equipped with a metal zip and two side handles for easy transport.

- Construction material: Nylon
- Bag Dimension (WxDxH): 1200 x 250 x 145 mm
- Packing Dimension (WxDxH): 460 x 380 x 25 mm
- Weight: 0,3Kg
- Packing Weight: 0.32kg

CODE	MSRP EUR	MSRP GBP
L857L	€12,34	£11.33



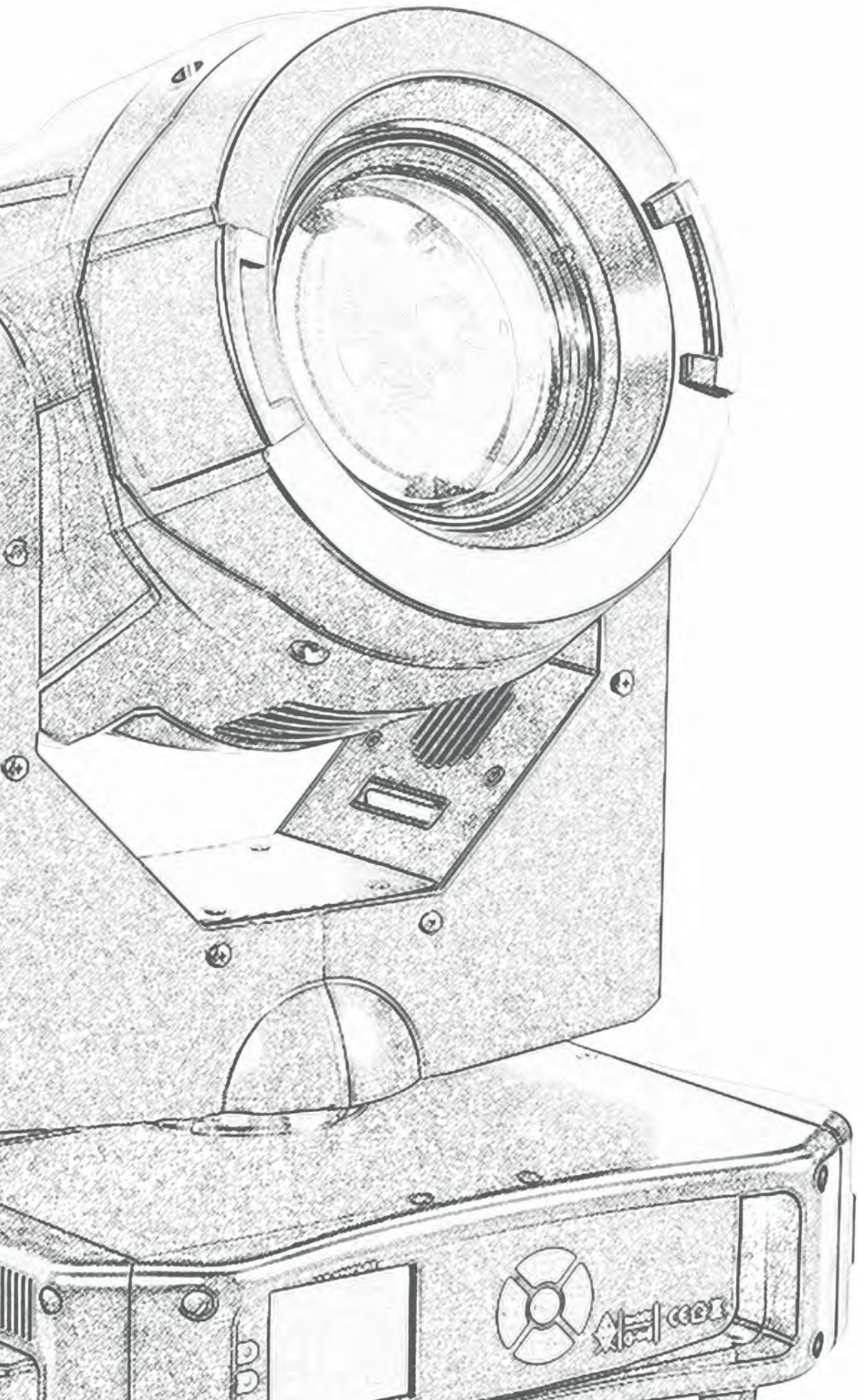

SHOW LIGHTING

SPIRE XL 440 SET - Set 2x Moving Heads Beam-Spot-Wash 20R with Flight Case

SOUNDSTATION SPIRE Series is enriched with a new professional tool for medium-large applications in both rental and fixed-installation venues. The SPRE XL 440 is a 3-in-1 moving head with a standard 440W 20R-type lamp. The optics and the effects allow the use as Beam, Spot or Wash fixture. The quality of mechanics, motor precision and high technology controls allow accurate, silent and precise movements. The presence of three gobos wheels, one color wheel with CTO, CTW and CMY filters, and two prisms make easy to play with color palette and effects, to satisfy even the most demanding light designers. The 3.7" touch-screen display and the front USB port allow the machine to be quickly set up, even when the unit is switched off. The set consists of two moving heads and a flight case with front doors and hook space, to facilitate the installation on stage especially in live contexts.

- 20R-Type Bulb Lamp
- 8000K Color Temperature
- 3in1 Beam/Spot/Wash Moving Head Operation
- Smooth Electronic Dimmer 0-100% with 1-20t/s Shutter
- Beam Angle from 2.3° to 56° with Electronic Linear Zoom and Focus
- Rainbow effect with color wheel
- Color Wheel with 12 colors + 2 CTO + 1 CTB + 1 CMY + White-Open + Semi-Color Effect
- 2 Fixed-Gobo wheels Gobos and 1 Rotating- Gobo wheel, all with Bi-Directional Flow Effect
- 8-Facet and 16-Facet Prisms
- Frost Effect for Wash Applications
- DMX512 control with RDM
- Accurate Cooling System with Intelligent Safety Protection System
- Front Panel with 3.7" Touch-Screen Color Display, 4-Button interface
- Micro-USB Port for External Power Adapter or Power-Bank, to allow Quick Unit Setting without Switching On the Unit
- Flight case with Frontal Loading System and Hook Space

- Lamp Source: 20R type
- Lamp Lifespan: from 1500h on (depending on lamp brand/model)
- CCT: 8000K - depending on lamp brand/model
- Beam Angle: 2.3° - 56° with linear focusing zoom
- Strobe: 1-20Hz, support mechanical strobe and adjustable speed strobe
- X/Y scan: Pan 540°, Tilt 270°; 3-phase motors with photoelectric reset and correction
- Color Wheel: 12 Colors + 2 CTO + 1 CTB + 1 CMY+ Open + Semi-Color Effect
- Fixed Gobo Wheel 1: 9 gobos + open + Shake + bi-direction flow effect
- Fixed Gobo Wheel 2: 10 gobos + 4 different size beam holes + Shake + bi-direction flow effect
- Rotation Gobo Wheel: 6 gobos + water wave glass endless rotation + white open + bi-direction flow effect
- Prism: 8 facet + 16 facet
- Control Modes: DMX512 (with RDM), Master-Slave, Auto
- DMX Channel Modes: 26CH/23CH
- Front panel: 3.7" Touch-Screen Display + 4 Buttons
- DMX Connections: 3-pin XLR Input, 3-pin XLR Output
- Power Connections: Power-Connector Input (blue), Power-Connector Output (grey)
- Voltage: AC100V-240V, 50/60Hz, Max Power Consumption: 600W
- Safety Protection: Power is cut-off in case of fixture overheating or system error
- Level of Protection: IP20
- Fixture Net Weight: 23.55 kg



CODE	MSRP EUR	MSRP GBP
E990E	€5.296,55	£4,862.23

SPIRE 280 BEAM SET - Kit composed by two SPIRE 280 BEAM Moving Heads with Flight Case

SPIRE series is a new line of professional beam moving heads designed to meet the needs of show lighting in rental and fixed installations contexts. The lineup consists of three models with standard 5R (200W), 7R (230W) and 10R (280W) metal-halide lamps, and a color temperature of 8000K. Ideal for medium-large environments, the emission angle of the light beam is 4° with a maximum luminance that in the model with 10R lamp reaches 38,000 Lux @ 20m (288,000 Lux @ 1m), with diameters ranging from 1.5m to 0.35m. PAN and TILT movements are driven by three-step motors and give greater accuracy and silence. SPIRE Series is equipped with 0° - 4° linear electronic focus which determines a powerful and well-defined beam, even at long distances. All models mount wheels-colors with 14 dichroic + white with rainbow effect, and a fixed gobo wheel with 17 gobos + white (6 colors + 11 neutral). There are an 8-facet prism and a 16-facet prism (which can be overlap) with self-rotation and shaking effect. The shutter creates strobe effects at a maximum of 13 Hz; the dimmer is linear from 0% to 100%. The DMX512 control is at 16 and 20 channels. The kit includes a practical and robust flight case in which the heads are put upside down. In the central part, there is a cable and accessories compartment. The kit also includes self-locking brackets for fixing the fixture to trusses (hooks not included), power cables and DMX. Two of the 4 wheels are braked.

- Standard 10R (280W) metal-halide lamps
- Pan 540° / Tilt 265° indexing, high precision Pan/Tilt movement, with 16bit automatic error correction, extra speed movements
- 3-phase motor for both PAN and TILT with faster moving speed and low-noise
- Luminous Flux: up to 288.000 Lux@1m
- 14+open color wheel with color correction devices. 2 CTO filters (3200K and 2500K) + 1 CTB filter, two-way rainbow effect, half color effects
- Gobo wheel: 11+open stamped fixed variable rotating metal gobos combine with 6 HQ dichroic / indexing / overlapping glass gobos; 3 beam diameter reducer filters on the fixed gobo wheel
- Gobo-Shaking function
- Gobo motorized focusing
- Frost filter for soft-edge projections
- Two indexing / superimposed /rotating prisms (16-facet circular prism and 8-facet circular prism), which is able to superimposed on all the gobos, both in and out of focus
- Full Color, touch-sensible, 180° Reversible LCD Menu Display with Battery backup (setup operable by end user without connecting the unit to power)
- Practical and robust Flight Case for 2 Units with wheels, featuring a cable/accessories compartment

- Lamp: Standard metal-halide 10R (280W)
- Voltage: AC110V-240V
- Frequency: 50/60Hz
- Power Consumption: 400W
- Fuse: F5A/250V (20x5mm)
- Color Temperature: 8000K
- Scan: Pan 540°, Tilt 265°, 16bit precision, photoelectric reset and correction
- Shutter: 1-13t/s mechanical control and speed adjustable
- Control: DMX512
- Channel Modes: 16CH /20CH switchable
- Control Mode: DMX/Sound Active/Auto
- Gobo wheel: 11 metal gobo + 6 glass gobo + open, electronic focus
- Color wheel: 14+open, rainbow effect, electronic focus correction
- Effect wheel: 8 facet prism + 16 facet linear prism, prism overlay and prism shaking
- Frost: 0-100% linear frost
- Display Battery: display board can be turned on without power to setup the unit
- Fixture Size (LxHxD): 270 x 500 x 326 mm
- Flight Case Size (LxHxD): 860 x 805 x 450 mm
- Fixture Weight (1 Unit): 17.1 kg
- Flight Case + 2 Fixtures Weight: 62.85 kg



CODE	MODEL	MSRP EUR	MSRP GBP
E498E	SPIRE 280 BEAM SET	€2.253,34	£2,068.57

■ Practical and robust Flight Case for 2 Units with wheels, featuring a cable/accessories compartment



soundSation
 SHOW LIGHTING



SPIRE 230 BEAM - SPIRE 230 BEAM Moving Head

SPIRE series is a new line of professional beam moving heads designed to meet the needs of show lighting in rental and fixed installations contexts. The lineup consists of three models with standard 5R (200W), 7R (230W) and 10R (280W) metal-halide lamps, and a color temperature of 8000K. Ideal for medium-large environments, the emission angle of the light beam is 4° with a maximum luminance that in the model with 7R lamp reaches 20,000 Lux @ 20m (217,500 Lux @ 1m), with diameters ranging from 1.47m to 0.37m. PAN and TILT movements are driven by three-step motors and give greater accuracy and silence. SPIRE Series is equipped with 0° - 4° linear electronic focus which determines a powerful and well-defined beam, even at long distances. All models mount wheels-colors with 14 dichroic + white with rainbow effect, and a fixed gobo wheel with 17 gobos + white (6 colors + 11 neutral). There are an 8-facet prism and a 16-facet prism (which can be overlap) with self-rotation and shaking effect. The shutter creates strobe effects at a maximum of 13 Hz; the dimmer is linear from 0% to 100%. The DMX512 control is at 16 and 20 channels. Packing includes self-locking brackets for fixing the fixture to trusses (hooks not included), power cables and DMX.

- Standard 7R (230W) metal-halide lamps
- Pan 540° / Tilt 265° indexing, high precision Pan/Tilt movement, with 16bit automatic error correction, extra speed movements
- 3-phase motor for both PAN and TILT with faster moving speed and low-noise
- Luminous Flux: up to 217.500 Lux@1m
- 14+open color wheel with color correction devices. 2 CTO filters (3200K and 2500K) + 1 CTB filter, two-way rainbow effect, half color effects
- Gobo wheel: 11+open stamped fixed variable rotating metal gobos combine with 6 HQ dichroic / indexing / overlapping glass gobos; 3 beam diameter reducer filters on the fixed gobo wheel
- Gobo-Shaking function
- Gobo motorized focusing
- Frost filter for soft-edge projections

- Lamp: Standard metal-halide 7R (230W)
- Voltage: AC110V-240V
- Frequency: 50/60Hz
- Power Consumption: 380W
- Fuse: F5A/250V (20x5mm)
- Color Temperature: 8000K
- Scan: Pan 540°, Tilt 265°, 16bit precision, photoelectric reset and correction
- Shutter: 1-13t/s mechanical control and speed adjustable
- Control: DMX512
- Channel Modes: 16CH /20CH switchable
- Control Mode: DMX/Sound Active/Auto
- Gobo wheel: 11 metal gobo + 6 glass gobo + open, electronic focus
- Color wheel: 14+open, rainbow effect, electronic focus correction



CODE	MODEL	MSRP EUR	MSRP GBP
E503E	SPIRE 230 BEAM	€922,64	£846.98

Twilight series

TWILIGHT 180 BEAM - 180W LED Beam Moving Head

This LED beam moving-head of TWILIGHT Series combines the benefits of LED technology (energy saving, low heat emission, increased reliability and durability over time) with the quality of digital control systems and the accuracy of its optical system. The TWILIGHT 180 BEAM is, therefore, a tool suitable for professionals of entertainment, both in touring and fixed installations. The optical system is able to emit a beam of 69.000 Lux @ 2m with 5° angle. The focus is motorized; dimmer is linear with a 0-20Hz frequency for strobe effects. The TWILIGHT 180 BEAM offers a 7 + white color wheel with rainbow effect, a first gobo wheel with 6 rotating gobos (3 metal + 3 glass) and a second wheel with 8 fixed gobos + open. Both gobo wheels have rainbow and shake effects. Finally, two prisms (one 8-facet, one 16-facet) with controllable rotation and direction, allow creating rich and varied light effects thanks to the overlapping feature. The chassis is largely made up of aluminum and allows to reduce the final weight in just 10kg. The fixture is available both in single carton and in two-unit professional flight case.

- LED: Ultra-bright 180W LED
- Lux: 69.000 Lux @ 2m
- Beam angle: 5°
- Motorized Focus
- 1 Color wheel and 2 Rotating Gobo wheels
- 2 prisms (8-facet + 16 facet) with overlap function
- Stand-alone, DMX, Master/Slave modes
- 13CH / 17CH DMX modes
- Lightweight yet tough housing



- Light emitting source: 1pc Ultra-bright 180W LED
- Beam intensity: 69.000 Lux @ 2m
- Beam angle: 5°
- Focus: Variable motorized focus
- Color wheel: 7 colors + white, split colors, rainbow effect
- Rotating Gobo wheel: 3 glass gobos + 3 metal gobos + open, gobo flow effect, gobo shake
- Static gobo wheel: 8 static gobos + open, gobo flow effect
- Effect wheel: 8 facet prism and 16 facet prism, adjustable rotating speed and direction. The two prisms can be overlapped
- Dimmer/Strobe: Dimmer variable electronic dimmer (0-100%), 0-20Hz
- PAN/TILT: Pan: 540°, Tilt: 222°, with adjustable speed
- Working modes: Stand-alone mode, DMX mode, Master/Slave synchronization mode
- DMX Control: 13CH / 17CH modes
- Housing: High temperature resistant engineering plastic + aluminum alloy
- Voltage: 100-240V, 50-60Hz
- Power consumption: 250W
- Fixture Size (LxHxD): 328 x 352min/406max x 328 mm
- Fixture Weight: 10.6kg

CODE	MSRP EUR	MSRP GBP
E069E	€864,48	£793.59



Twilight series

TWILIGHT 60 ENDLESS - 60W RGBW 4in1 LED Moving Head with Infinite PAN/TILT Movement

This LED spot moving-head of TWILIGHT Series combines the benefits of LED technology (energy saving, low heat emission, increased reliability and durability over time) with the quality of digital control systems and the accuracy of its mechanics. The TWILIGHT 60 ENDLESS is, therefore, a tool suitable for professionals of entertainment, both in touring and fixed installations. The light source consists of 1 high-brightness RGBW 4in1 LEDs, capable of emitting a beam of 30,000 LUX @ 1m. The front lens, with 4° opening, ensures optimal mixing of the four base colors, thus obtaining an extremely smooth and concentrated light beam. PAN and TILT movements are equipped with high-precision motors and 8/16bit digital control. In addition to the traditional PAN-TILT movements at 540° and 270°, you can use 360° endless motion, creating dynamic effects that are highly appreciated in both live and disco applications. The chassis is largely made up of aluminum and allows to reduce the final weight in just 3.3kg. The fixture is available both in single carton and in 4-unit professional flight case.

- LED: Ultra-bright 60W RGBW 4in1 LED
- Lux: 30.000 @ 1m
- Beam angle: 4°
- PAN-TILT: 540° / 280° + Endless function
- Stand-alone, DMX, Master/Slave modes
- 14CH / 16CH DMX modes
- Lightweight yet tough housing

- Light emitting source: 1x60W RGBW 4in1 LED
- Beam intensity: 30.000 Lux @ 1m
- Beam angle: 4°
- Dimmer/Strobe: Dimmer variable electronic dimmer (0-100%), 0-20Hz
- PAN/TILT: Pan: 540°, Tilt: 270°, with endless function
- Working modes: Stand-alone mode, DMX mode, Master/Slave synchronization mode
- DMX Control: 14CH / 16CH modes
- Housing: High temperature resistant engineering plastic + aluminum alloy
- Voltage: 100-240V, 50-60Hz
- Fuse: T3A-250V, 5x20mm
- Power consumption: 115W
- Fixture Size (LxHxD): 170 x 262 x 202 mm
- Fixture Weight: 3.3kg



CODE	MSRP EUR	MSRP GBP
E070E	€378,00	£347.00

TWILIGHT 180 BEAM CASE - Flight Case for 2 TWILIGHT 150/180 BEAM

Flight Case for 2 TWILIGHT 150/180 BEAM moving heads

- Wheel Diameter: 75 mm
- Case Size (WxHxD): 74x63.5x38 cm
- Net Weight (Only Case): 5 kg

CODE	MSRP EUR	MSRP GBP
E251E	€180,79	£165.97





MHL-60 MKII ZOOM - LED Beam Mobile Head with one 60W RGBW 4in1 LED and Zoom

MHL-60-MKII is a compact beam moving head equipped with a single high brightness 60W RGBW 4in1 LED, extremely bright and reliable. Pan/Tilt movements are accurate and silent with 16-bit resolution. Zoom ranges from 2.5° and 60°. It can be used in either Master / Slave DMX, Manual, Auto (7 different modes) and Sound (2 modes). DMX512 control is 14CH.

- RGBW 4in1 60W ultra-bright LED
 - BZoom: 2.5° - 60°
 - Electronic dimmer: 0 - 100% linear
 - Strobe: 1 - 10t/s
 - Control mode : DMX512 15CH, Manual, Master/slave, Auto, Sound
 - Pan: 540°
 - Tilt: 220°
 - LCD Display user interface
 - Accessories: 1m Powercon mains cable; 1.5m DMX cable
- Max consumption rate : 85 watt
 - Power requirements : AC 110-240V / 50~60Hz
 - Socket DMX IN: 3 pin XLR F
 - Socket DMX OUT: 3 pin XLR M
 - Mains socket: Powercon
 - IP Protection: IP20
 - Controllo DMX: 15CH
 - Dimensions: 20.1 x 19.6 x 31.7 cm
 - Net weight : Kg 3.8

CODE	MSRP EUR	MSRP GBP
L801L	€435,82	£400.08



AXIS III - 3-Head Moving Light with 3 x 10W 4IN1 CREE LEDs

AXIS III is an intelligent fixture with 3 mini moving heads, each equipped with 1 high-brightness CREE 10W RGBW 4in1 LED. Thanks to the DMX modes at 6CH, 9CH, 11CH and 21CH it is possible to access different levels of control complexity, up to the complete independence of each movement and color for each of the three heads. It is also possible to use the AXIS III without a DMX control unit, thanks to the 16 automatic Show modes, Master / Slave and Sound.

- 3 pieces of 10W RGBW 4in1 CREE high brightness LEDs
- LED lifetime between 80,000 and 100,000 hours
- 4 operation mode: DMX control, Master/slave, Auto run, Sound
- DMX Mode: 6CH, 9CH, 11CH, and 21CH
- User Interface with LED display, easy to be controlled
- Luminance: Red - 3400 Lux @ 1m, Verde - 4900 Lux @ 1m, Blue - 8200 Lux @ 1m, White - 11000 Lux

- Light Source: 3 pieces of 10W RGBW 4in1 CREE high brightness LEDs
- LED lifetime: Between 80,000 and 100,000 hours
- Beam Angle: 8°
- Luminance (Lux @ 1m): Red 9000, Green 14000, Blue 20000, White 26000
- PAN: 540°, 16bit fine
- TILT: 270°, 16 bit fine
- Operation mode: DMX control, Master/slave, Auto run, Sound
- DMX Mode: 6CH, 9CH, 11CH, and 21CH
- Dimmer: Electronic Linear Dimming 0-100%
- Voltage: AC 100-240V / 50~60Hz
- Power consumption: 50W
- Fuse: F3A L250V (5x20mm)
- Fixture Size (LxHxD): 34 x 25 x 34 cm

CODE	MSRP EUR	MSRP GBP
E369E	€394,44	£362.10



AXIS IV MKII - 4x32W RGBW LED 4 Head Beam Moving Head

When giving colors to your gigs passes through simplicity of use, portability and the benefits of modern LED technology, AXIS IV MKII becomes the reference to all musicians, DJs and entertainment operators. AXIS IV MKII has been designed to be all-in-one system. This bar offers 4 moving heads able to swivel by up to 540° horizontally and 270° vertically, with extremely fast and accurate movements. It can be mounted on a truss and on lighting supports with Ø35mm pole, thanks to the supplied adapter. Each moving head mounts a 32W RGBW 4in1 LED with beam angle from 6° which ensures brilliant colors, high performance in terms of brightness and duration. Each head, also, can be controlled independently both in PAN/TILT movements and colors. Control modes are Sound, DMX Master/Slave, and Auto. It is also available (optional) a professional flight case with wheels (2 with brake) for two bars (AXIS IV MKII CASE – SKU: J684J).

- Bar with four-head LED moving light (4pcs 32W RGBW 4in1)
 - Easy to control by LCD Graphic Display
 - 6° Beam Angle
 - Light Lumen @1m from 24000 to 68000 LUX
 - Standalone Operation
 - Sound Control via built-in microphone
 - Master/Slave synchronization
 - DMX-512 protocol with 5 channel modes (6CH, 10CH, 19CH, 32CH and 56CH DMX)
 - 2 bundled Fast lock Omega Brackets
 - Bundles Ø36mm Stand Adapter (stand not included)
- Light source: 4x 32W RGBW 4in1 LED
 - Brightness @ 1m (single head): R 24000 Lux; G 50000 Lux; B 80000 lux; W 68000 lux
 - Brightness @ 2m (single head): R 11500 lux; G 18000 Lux; B 27000 Lux; 26000 lux
 - Colors: RGBW with color mixing
 - Beam corner: 6°
 - Control mode: DMX512, Master / Slave, Sound, Auto
 - DMX mode: 6CH / 10CH / 19CH / 32CH / 56CH
 - Power connectors: PowerCon input / output
 - DMX connectors: In/Out XLR 5-Pin + In/Out XLR 3-Pin
 - Display: 2.4 "TFT LCD
 - Power supply: 110V ~ 240V - 50-60Hz
 - Max Power Consumption: 200W
 - Fuse: F3AL / 250V (5x20mm)
 - Bar size (WxDxH): 1003.6 x 115 x 271.4 mm
 - Bar weight: 11.5 kg
 - Packaging dimensions (WxDxH): 1090 x 180 x 360 mm
 - Packaging Weight: 13.25 kg
 - Accessories supplied: 1x power cable, 2x quick-lock omega-type brackets, Ø36mm pole adapter (stand not included)

CODE	MSRP EUR	MSRP GBP
J683J	€771,33	£708.08



AXIS IV MKII CASE - Flight Case for 2 AXIS IV & AXIS IV MKII LED Bars

Flight Case 2in1 for 2pcs of AXIS IV Series Bars with wheels.

- Ø100mm Wheels (2 with brake)
- Case Size (WxDxH): 115 x 40 x 49 mm

CODE	MSRP EUR	MSRP GBP
J684J	€297,25	£272.88



Twilight series

TWILIGHT 150 SPOT - 150W LED SPOT Moving Head

This LED spot moving-head of TWILIGHT Series combines the benefits of LED technology (energy saving, low heat emission, increased reliability and durability over time) with the quality of digital control systems and the accuracy of its optics. The TWILIGHT 150 SPOT is, therefore, a tool suitable for professionals of entertainment, both in touring and fixed installations. The optical system is able to emit a beam of 50.000 Lux @ 1m with 15° angle. The focus is motorized; dimmer is linear with a 0-20Hz frequency for strobe effects. The TWILIGHT 150 SPOT offers a 8 + white color wheel with rainbow effect, a first gobo wheel with 7 rotating gobos (4 metal + 2 glass + 1 water ripple gobo) and a second wheel with 9 fixed gobos + open. Both gobo wheels have rainbow and shake effects. Finally, a 3-facet and a linear prisms (both with controllable rotation and direction) and frost, allow creating rich and varied light effects. The chassis is largely made up of aluminum and allows to reduce the final weight in just 9.2kg. The fixture is available both in single carton and in two-unit professional flight c

- LED: Ultra-bright 150W LED
- Lux: 50.000 @ 1m
- Beam angle: 15°
- Motorized Focus
- 1 Color wheel and 2 Gobo wheels
- Prism: 1 circular, 1 linear + Frost and overlapping feature
- Stand-alone, DMX, Master/Slave modes
- 13CH / 16CH DMX modes
- Lightweight yet tough housing

- Light emitting source: 1pc Ultra-bright 150W LED
- Beam intensity: 50.000 Lux @ 1m
- Beam angle: 15°
- Focus: Variable motorized focus
- Color wheel: 8 colors + white, split colors, rainbow effect
- Rotating Gobo wheel: 2 glass gobos + 4 metal gobos + 1 Water Ripple Gobo + Open, gobo flow effect, gobo shake
- Static gobo wheel: 9 static gobos + open, gobo flow and shake effects
- Effect Wheel: 3-facet circular prism, 6 facet linear prism and frost, adjustable rotating speed and direction
- Dimmer/Strobe: Dimmer variable electronic dimmer (0-100%), 0-20Hz
- PAN/TILT: Pan: 540°, Tilt: 222°, with adjustable speed
- Working modes: Stand-alone mode, DMX mode, Master/Slave synchronization mode
- DMX Control: 13CH / 16CH modes
- Housing: High temperature resistant engineering plastic + aluminum alloy
- Voltage: 100-240V.50-60Hz - Fuse T5A-250V, 5x20mm
- Power consumption: 230W
- Fixture Size (LxHxD): 328 x 352min/400max x 216 mm
- Fixture Weight: 9.2kg



CODE	MSRP EUR	MSRP GBP
E071E	€788,88	£724.19

TWILIGHT 150 SPOT CASE - Flight Case for 2 TWILIGHT 150 SPOT

Flight Case for 2 TWILIGHT 150 SPOT moving heads

- Wheel Diameter: 75 mm
- Case Size (WxHxD): 62x58x38 cm
- Net Weight (Only Case): 15.1 kg

CODE	MSRP EUR	MSRP GBP
E253E	€180,79	£165.97



THEISIS 1240RZ - 12 x 40W LED Moving Head with zoom

THEISIS series offer la new wash-light moving head THEISIS 120RZ with 12 powerful and reliable 40W OSRAM LEDs. It represents a valid alternative to normal arch lamps with all the benefits of LED technology: low consumption, longer life, lower temperature dissipation. The light beam ranges from 4.5° to 45°, thanks to the ZOOM function controlled by three motors simultaneously, which give an extremely soft and silent adjustment. The quad-color mixing system, the adjustable color-temperature, the accurate and linear dimmer, combined with the sophisticated control of the single pixels, make the new THEISIS 1240RZ moving head a valid tool to enhance the creativity of the most demanding light designers. It offer several Pixel controlling functions: rainbow, single pixel, circle, full-control of the single colors of each LED, and many others. Particular attention is paid to precision and noise of mechanical movements. PAN and TILT are equipped with three-phase motors and 16-bit control. The ZOOM is managed by three motors, to minimize skating effect and vibrations. The electronic dimmer is accurate and soft. Fan speed is also electronically controlled by the internal temperature, ensuring the right balance between noise, safety and durability of the LED chips.

- LED light: LED 12 x 40W RGBW OSRAM® with LED lifespan of around 50000 hours.
- Beam angle (scan type): 4.5°÷45°
- Electronic smooth Dimmer with 16-bit control.
- Strobe: 1-20Hz with instant light ON and OFF work mode.
- RGBW smooth color mixing with Pixel effects, like rainbow, single pixel, circle, full control, fixed background light color mixing, fixed background light pattern, fixed background light pixel control.
- ZOOM function 9° ÷ 44° /1.7s, with 3 silent motors at the same time to provide accurate zooming, stable beam, without skating.
- PAN and TILT with 8-16 bit scanning, photoelectric reset and automatic error correction function.
- DMX512 / Master-Slave / Auto / Sound control Modes
- Four DMX Channel Modes: 17CH Standard, 58CH Extended, 18CH Pattern, 11CH HIS.
- High efficiency cooling system with whole-process temperature monitoring. No risk of LED lamp damage; Intelligent speed control fan and monitoring of rotation speed
- 2.0" LCD color screen with easy user-interface.
- External power function with USB connection for moving head parameter setting using display.

- LED light: 12 x 40W RGBW OSRAM®
- LED Lifespan: 5000 Hours
- Voltage: 100V-240V 50-60Hz
- Power consumption: 600W
- Amperage: 2,5A
- Control mode: DMX512, Master/Slave, Auto, Sound
- Channel Mode: 18CH, 58CH, 17CH, 11CH
- Network function: Support RDM, Art-Net®, Kling-Net and sACN networking protocols (Optional).
- Beam angle (Scan type): 4.5° ÷ 45°
- Dimmer: 0-100% (16bit)
- CCT: 2800K-8500K
- Zoom: 9° ÷ 44° /1.7s, with 3 silent motors at the same time to provide accurate zooming, stable beam, without skating.
- X/Y Scan: Pan 540°,Tilt:270°
- Strobe: 1-20Hz
- Display: 2" Color LCD, English and Chinese switchable languages, Reversible
- Housing: Flame-retardant plastic
- Internal Running Temperature: 0 ÷ 40°C
- Dimensions (WxDxH): 395 x 265 x 410 mm
- Weight: 14.35 kg
- Package Weight: 17Kg



CODE	MSRP EUR	MSRP GBP
E943E	€1.839,17	£1,688.36

THEISIS 1240RZ SET - 2x THEISIS 1240RZ Moving Head Set with Flight Case

CODE	MSRP EUR	MSRP GBP
E946E	€3.899,28	£3,579.54



THEISIS 1912 ZOOM - 19 x 12W 4IN1 LED Moving Head With Zoom

THEISIS 1912 ZOOM LED moving head is part of a wider range of SOUNDSATION DMX intelligent LED Moving Head Lights. This lighting is compact, lightweight and very easy to use. It's been designed to meet more customers' demand, thanks to the ultra-smooth dimmer, the Zoom function (15°-60°), and the 3 light-emitting zones with DMX RGBW independent control. It can be used as both spot and wash light, in order to meet various lighting applications. Not only, but thanks to the 16-bit of precision on movement driving and dimming, it creates extremely fine strobe, dimmer and positioning effects. Finally, the multi-function LCD operation is developed to help the user setting the unit up, making this fixture easy to use, reliable in performance and versatile in applications. A MUST for all lighting professionals.

- 19 x 12W RGBW CREE LEDs with max 42400 Lux (full bright @ 1m - 15° beam)
- Super long-life LED with 100000 hours operation, low energy consumption, energy saving, and environmental protection LED
- Uniform RGBW color mixing system and rainbow effect with 3 concentric Zones (12pcs LED on external ring, 6pcs LED in the middle, 1pc LED in the centre)
- 0-100% Linear Dimmer with 65536 brightness levels, to achieve a truly 16-bit dimming and eliminate the eight-dimming low light jitter
- Smooth Zoom function from 15° to 60°
- Lens without attenuation
- 3 kinds of control modes: DMX, Master/Slave Auto, Sound Control
- 22/14 DMX Channel Modes
- 1~25t/s Strobe effects (with Electronic regulating or Random)
- Horizontal scanning: 540° (16-bit precision scanning)
- Vertical scanning: 265° (16-bit precision scanning)
- TFT LCD display with user-friendly interface

- Light Source: 19 pieces of 12W RGBW 4in1 high brightness CREE LEDs
- Luminance: Max 42400 Lux @1m (Full bright, 15° Beam Angle)
- LED lifetime: Around 100,000 hours
- Beam Angle: From 15° to 60° with DMX controlled zoom
- PAN: 540° (16bit precision scanning)
- TILT: 265° (16bit precision scanning)
- Operation mode: DMX control, Master/slave, Auto run, Sound
- DMX Mode: 14CH and 22CH
- Dimmer: 0-100% Linear Dimmer with 65536 brightness levels
- Strobe: 1~25t/s Strobe effects
- Noise: 48.1dB @ 7m; 48.2dB @ 6m; 49.2 dB @1m
- Voltage: AC 100-240V / 50~60Hz
- Power consumption: max 300W
- Fuse: F10A L250V (5x20 mm)
- Fixture Size (LxHxD): 300 x 410 x 200 mm - Fixture Weight: 7.4 kg



CODE	MSRP EUR	MSRP GBP
E388E	€807,08	£740.90

THEISIS 1912 ZOOM SET - 4pcs THEISIS 19112 ZOOM Set with Flight Case

- Professional Flight Case with wheels (two wheels with brake)
- Flight Case Size: 810 x 560 x 720 mm

CODE	MSRP EUR	MSRP GBP
E391E	€3.460,73	£3,176.95

PAR-10W-7-R - 7x10W RGBW+AV 6IN1 PAR Light with Remote Control

PAR-10W-7-R is equipped with 7 pcs ultra-brightness 10 W LED (6in1) so that it meets most of live or fixed installation application. Compact housing design help the heat radiation so it works more stably in despite of how rigorous condition it is. What's more, it is driven by the latest dimmer technology so it brings you more smooth and excellent color mixture. Finally, the IR remote control function make it very easy use. Even without a DMX controller.

- 2300 lux @ 2 meter
- Advanced dimmer system
- IR remote control
- Lightweight; only 1.1kg

- Mains Voltage: 110V ~ 240V, 50-60HZ
- Power Consumption: 80W
- LED: 7x 10W High-brightness 6in1 (RGBWA+UV) LEDs
- Full Color Lux: 2300 lux @ 2m; 990 lux @ 1m
- Control mode: DMX512 9CH, Master/Slave, Manual, Sound Active, Auto
- Housing Material: ABS
- Optical System: 25° angle lens
- IP Rate: IP20
- Working Temperature: -20 °C to 50 °C
- Dimension (WxHxD): 19 x 14 x 16 cm - Net Weight: 1.1 kg
- Accessory: Remote Control



CODE	MSRP EUR	MSRP GBP
L650L	€100,07	£91.86

PAR-181R - 18x1W (6R, 6G, 6B) LED PAR Light with remote control

PAR-181R combines LED technology benefits with DMX and IR remote control in a lightweight housing. It is equipped with 18pcs ultra-brightness 1W LED (6 Red, 6 Green, 6 Blue) and it meets many live or fixed installation applications. The compact housing design helps heat radiation so it works more stably in despite of how rigorous condition it is. What's more, it is driven by the latest dimmer technology so it brings you more smooth and excellent color mixture. Finally, the IR remote control function make it very easy use. Even without a DMX controller.

- Light source: 18x1W (R6, G6, B6)
- Color temperature: 6000-6500K
- LED lamps Life Time: 60000 hours
- Beam angle: 25°
- Control panel: 4 Digital LED display digits
- Control mode: Sound activation, Auto, Master/Slave, DMX512, IR remote
- DMX Control: 7CH
- IR remote: up to 10 meters

- Voltage: AC100-240V, 50Hz/60Hz
- Power consumption: 25W
- Working environment: Indoor, -20°C to 40°C
- Protection rate: IP20
- Dimension size (WxHxD): 177 x 180 x 150 mm (brackets installed)
- Net Weight: 0.8 kg



CODE	MSRP EUR	MSRP GBP
L991L	€46,30	£42.50

SESTETTO 1012 SLIM - 12x10W RGBWAV 6IN1 Slim LED Projector

"Sestetto" slim PAR series offers to light designers and professionals a complete lineup of slim wash PARs with 10W LEDs, featuring up-to-date RGBWAV 6in1 technology and high quality lenses with 25 ° beam. The series consists of 3 models with 18, 12 and 7 LEDs, respectively, to fit different size environments. All models, however, offer the same color palette by perfect mixing the 6 basic colors: red, green, blue, cold white, amber and UV. Illuminance at 2 meters is 2280 Lux (Sestetto 1007 Slim), 2950 Lux (Sestetto 1012 Slim) and 4500 Lux (Sestetto 1018 Slim). They can work in DMX, Master / Slave, Sound, Auto and Manual modes; DMX control features 11 channels. Cooling fan speed varies according to internal temperature and minimizes overall noise. The rugged, lightweight, and plastic slim chassis (only 11 cm), and the double mount bracket greatly increase the value for money of this series and make it suitable for use even in tight places.

- Beam Angle: 25°
- Slim Housing Design (11cm)
- 12 pieces of 10W RGBWAV 6in1 LED
- Illuminance @ 2 meters: 2950LUX (all colors)
- Power Consumption: 150W
- Control Modes: DMX, Master/Slave, Sound, Auto and Manual
- DMX Control: 11 or 7 channels
- Intelligent Fan Speed Control
- Mains: AC110V-240V - 50/60Hz
- Protection Degree: IP20
- Fixture Size: 310 x 260 x 220 mm - Fixture Weight: 2.8 kg



CODE	MSRP EUR	MSRP GBP
L218L	€202,28	£185.69

SESTETTO 1012 SLIM SILENT - Indoor Slim PAR with 12 x 10W 6in1 LED no Fan

SOUNDSATION SESTETTO 1012 SLIM SILENT meets the needs of those professionals who need a powerful PAR for indoor applications, with 6IN1 LED technology, and suitable for quiet environments (such as theaters, conference rooms, or venues where noise has to be avoided as much as possible). The aluminum housing, able to dissipate the most of the heat produced by LED chips and circuitry, allows convection cooling and makes unnecessary the use of fans that, as silent they might be, however, can cause trouble in particular environments. The light source consists of 12 x 10W LEDs, selected for maximum durability and color emission. In total, they are capable of emitting 5800Lux at 2 meters (with all 6 colors at full). The 6IN1 technology enriches the color palette by adding, in addition to the classic R/G/B/W, amber, and ultra-violet, allowing you to create shades even more special. Finally, a special note deserves the attention to reliability and durability. The SESTETTO 1012 SLIM SILENT, in fact, adopts a new technology that adjusts the dimmer curve to the internal temperature. This, in addition to increase security, considerably lengthens LED chip lifespan.

- High level aluminum housing design
- No fan indoor par light, which can provide you a perfect quiet environment
- High brightness (5800Lux @ 2m, full color)
- 6IN1 Led, which give more color tints with UV and Amber components
- Half power under high temperature with Dimmer Curve adjusting

- Light source: 12pcs x 10W LED
- Color: RGBWA+UV (6IN1)
- Brightness: 5800Lux @ 2m (full color)
- Beam Angle: 15°
- Dimmer: 0 ~ 100%, linear
- Strobe: 0 ~ 20t/s
- DMX512: 13/8 channel modes, switchable
- Master/slave Modes: Yes
- Manual control: Yes
- Sound Active Mode: Yes
- Auto Mode: Yes
- Voltage: 110V ~ 240V, 50/60Hz
- Power consumption: 150W
- Operating temperature: -10°C ~ 45°C
- Fixture Size (WxHxD): 28 x 22.7 x 22 cm (excluding brackets)
- Fixture Weight: 3.6 kg



CODE	MSRP EUR	MSRP GBP
L774L	€290,54	£266.72

BAR-18-12W-IP65 - BAR-18-12W-IP65

BAR-18-12W-IP65 is a slim bar with individual control of 18 High Power LEDs. It is a compact and powerful fixture for both indoor and outdoor use. The bar is equipped with powerful RGBW LED chips of 4in1 technology and allows light designers a variety of effects and programming options. The specially designed housing ensures an optimum heat dissipation during operating. An elegant design along with ease of use result in a complete and beautiful product for any indoor or outdoor application.

- Bar with 18 LED (12W RGBW 4in1)
- Easy to control by a simple control panel and 4 x Seven Segments Display
- Color mixing: RGBW
- Electronic dimming: 0-100% linear dimming
- Standalone Operation
- Sound Control via built-in microphone
- Master/Slave synchronization
- DMX-512 protocol
- 9CH/23CH/72CH Channel Modes
- Strobe mode
- 2 Bundled Mount Brackets for fixing to the ground, wall or ceiling
- Light source: 18*12W RGBW 4in1 LED
- Voltage: 100V ~ 240V - 50-60HZ
- Power consumption: 240W
- LED: 18 x 12W
- Colors: RGBW Color Mixing
- Control Modes: DMX512(9CH/23CH/72CH), Master/Slave, Sound Mode, Auto Mode
- Power Supply Connectors: IP65
- DMX Connectors: IP65
- Bundled Accessories: 1 x Power Cord, 1 x DMX Cable, 2 x Mount Brackets, 1 x Owner's Manual
- Dimension (WxHxD): 990 x 150 x 90 mm - Weight: 6,8 kg



CODE	MSRP EUR	MSRP GBP
E809E	€318,84	£292.70



PAR-5-18W-IP65 - 5x18W RGBWA+UV 6in1 Waterproof Flat Par Can

Especially designed for outdoor use thanks to the IP65 protection degree, this fixture really flat (only 13 cm). Despite its size, it has a maximum light emission capacity of 7000 Lux and, thanks to the 6in1 LED technology is able to offer a wide color palette. The PAR-5-18W-IP65 can be used for external architectural applications and in contexts with high presence of moisture. DMX control is from 2CH to 9CH. The control modes are Master-Slave, Sound, Jump, Fade and Auto. Product packing includes 1pc of 1m mains cable with Schuko plug and D21mm IP65 female connector, and 1pc of 1m DMX cable with XLR 3-P male and D17mm IP65 DMX female connector.

- Light source: 5pcs 18W RGBWA+UV 6in1 LEDs
- IP Rate: IP65
- Lens Angle: 18°
- Up to 7000 Lux
- Built-in Master-Slave, Sound Control, Jump Mode, Fade Mode and Auto mode
- Built-in Various Strobe Functions
- Static LED dimmer and color selectable internally and through DMX512
- LED display, easy to control
- Suitable for outdoor venues like disco, club, bar, party and DJ moving show
- DMX Channel Modes: 2CH, 3CH1, 3CH2, 4CH, 5CH, 6CH, 9CH

- Voltage: AC100-240V 50/60Hz
- Power Consumption: 100W
- Product Size (WxHxD): 19 x 19 x 13 cm - Net Weight: 3 kg



CODE	MSRP EUR	MSRP GBP
L752L	€197,21	£181.04

WDX-100 - 2.4GHz DMX512 wireless transmitter for Soundsation 5x18W and 5x10W Battery Powered Pars

WDX-100 is a 2.4GHz wireless DMX512 interface for Soundsation PAR-18-4-BW and PAR-10-5-BW and allows them to be controlled without the use of DMX cables. The system operates on 2,400-2,525 GHz licence-free band and can be used on maximum 7 transmitter-receiver pairs, for a total of 126 DMX channels. Setting it up is easy and immediate. The device requires an external power supply (included).

- Up to 7 transmitter-receiver pairs simultaneously
- Up to 126 DMX512 channels
- Controls: 1 setup button to change ID value; 1 LED to show 7 different colors according to the chosen ID; 1 power connector.
- Power requirement: 5Vcc, 1A (adapter included)
- Dimension (without antenna): 137mm x D18mm
- Dimension (with antenna): 215 x D18mm
- Net weight: 0.08 kg

CODE	MSRP EUR	MSRP GBP
L416L	€115,04	£105.61



Cavi IP65

**WEC-17DMX-03
3m Waterproof DMX Extension Cable
D17mm**



- IP Rate: IP65
 - Cable Type: DMX
 - Length: 3m
- | CODE | MSRP EUR | MSRP GBP |
|-------|----------|----------|
| L757L | €12,49 | £11.47 |

**WEC-21POWER-03
3m Waterproof Mains Extension Cable
D21mm**



- IP Rate: IP65
 - Cable Type: Mains Cable
 - Length: 3m
- | CODE | MSRP EUR | MSRP GBP |
|-------|----------|----------|
| L759L | €12,49 | £11.47 |

**WEC-30POWER-03
3m Waterproof Mains Extension Cable
D30mm**



- IP Rate: IP65
 - Cable Type: Mains Cable
 - Length: 3m
- | CODE | MSRP EUR | MSRP GBP |
|-------|----------|----------|
| L760L | €12,49 | £11.47 |

**WADC-30POW-015
1.5m Waterproof Power Cable**



- 1.5m Power Cable, 3x2.5mmq conductors, Schuko plug, IP65 Female Connector with 29mm Diameter - Length: 1.5m
- | CODE | MSRP EUR | MSRP GBP |
|-------|----------|----------|
| L904L | €9,21 | £8.45 |

**CAB-IP65-DMX
1.5m Waterproof DMX Cable**



- 1.5m Waterproof DMX Cable with 3-Poles XLR Plug and D23.5mm 3-Poles IP65 Female Connector - Length: 1.5m
- | CODE | MSRP EUR | MSRP GBP |
|-------|----------|----------|
| L905L | €5,91 | £5.43 |

LIGHTBLASTER 104 COB - 4x100W Warm White + Cold White COB LED Blinder

Lightblaster LED blinders series combines the benefits of LED technology (energy saving, reliability and durability over time) with lighting requirements in the photographic, television and stage industry. The design is very essential and functional; the chassis is completely metal to facilitate the cooling of light sources. Programming and setting are extremely simple, and DMX512 allows these blinders to be remote controlled. All PARs are equipped with color temperature regulation system, which allows you to mix cold and warm white (3200 - 6500K) depending on your needs. The advanced cooling system reduces fan noise according to the internal temperature and allows them to be used even in situations where low noise is required. The advanced dimmer system provides various adjustment curves to fit the device to different requirements. Finally, the absence of flicker and dithering allows the use in television studios. The fixtures come with 100W COB LEDs (50W CW + 50W WW) with high brightness and durability.

- 4x100W COB LED (50W Cold White + 50W Warm White)
- Color Temperature: 3200-6500K with mixing regulation
- Light Intensity: 16900 Lux @1m
- Advanced Dimmer System with different Variation Curves
- Long life span (50000 - 100000 hours)
- Lens Angle: 60°
- No flicker, No dithering, No Jitter
- Advanced cooling system for fan noise reduction

- Voltage: 110V ~ 240V, 50-60HZ
- Power Consumption: 250W max
- LED: 100W x 4PCS COB
- Operative Modes: DMX, Master/Slave, Manual, Sound, Auto
- DMX512 Modes: 8CH, 4CH, 2CH, 1CH
- Light Body Material: Aluminum
- Lens Angle: 60°
- Strobe: 1-10t/s
- Dimmer Frequency: 1000Hz
- Fixture Size: 37x35x19cm
- Fixture Weight: 8.25kg



CODE	MSRP EUR	MSRP GBP
E260E	€419,67	£385.26

LIGHTBLASTER 616 LED - LED Strobe Light with 616pcs of 0.5W Pure White (6500K) LEDs

LIGHTBLASTER 616 LED is a high brightness Strobe light that combines reliability, lifespan, and brilliance of the Pure White LED chips (6500K) with the very low power consumption compared to traditional Xenon lamps. The beam angle is 120° but, thanks to the supplied barn-door (removable), it is possible to reduce it to 0°. Its light source consists of 616 high-brightness long-lifetime 0.5W LEDs. Color Temperature is Pure White (6500K). The electronic dimming control offers 5 different curves, to adapt this fixture to any type of use. The internal temperature is controlled by sensors that, in case of overheating, lower power to 50% and adjust cooling fan speed. The result is a powerful yet extremely silent strobo-light. Not only, but the robust ABS housing makes it lightweight, durable and with an excellent value for money.

- Light source: 616 pieces of 0.5W Pure White (6500K) high brightness LEDs
- Beam Angle: 120°, with adjustable Barn-door
- 5 Dimmer Curves: 1 Linear + 4 with different Attack/Release times
- Intelligent Temperature Control (When temperature goes up to 80°C, power consumption reduces to 50%; when temperature goes down to 65°C, the unit recovers 100% power consumption)
- Intelligent Fan speed Control (Fan speed automatically adjusts according to machine temperature)
- Maximum Noise: 43dB @1m distance
- Built-in Programs: strobe, auto, sound active, and preset colors
- DMX Modes: 2CH / 5CH and 9CH

- Light source: 616 pieces of 0.5W Pure White (6500K) high brightness LEDs
- Beam Angle: 120°
- Detachable Barn-door system
- Strobe: 0-30Hz
- Dimmer: Electronic Linear 0-100% with 5 curves (1 standard + 4 with different Attack/Release Times)
- Control Mode: DMX512 / Manual / Master-Slave / Sound
- DMX Modes: 11CH / 6CH (selectable)
- Built in programs: 5 Strobe + 6 Auto + 2 Voice Control
- Cooling Systems: Fan with temperature detection and over-heating protection
- Maximum Noise: 43dB (@1m)
- IP Rate: IP20
- Voltage: AC110V/240V - 50/60Hz
- Max Power Consumption: 350W
- Housing Material: ABS
- Fixture Size: 430 x 220 x 84 mm



CODE	MSRP EUR	MSRP GBP
E497E	€274,40	£251.90

LIGHTBLASTER 3000 DMX - 3000W DMX Strobe Projector

LST-3000 is an extremely powerful and professional strobe light. It is equipped with a 3000W Xenon long lasting lamp and can be controlled by DMX512 protocol. The unit has a smart overheating electronic protection.

- 3000 W long-lasting Xenon lamp
- Color temperature: 5600K
- Lux: 5200 @ 2m (blinder mode)
- Continuous blinder effects with auto fade
- Smart integrated heat control
- Fan cooling
- 4 channels DMX, flash intensity, flash duration, flash rate and pre-programmed effects
- Control modes: DMX, manual, master/slave
- Dimmer: 0-100%

- Power requirements: 220V, 50Hz
- Power Consumption: 3000W
- Typical Current Consumption: 8A in normal Mode; 15A in High Power Mode
- Peak Current Consumption: 33A
- Minimum Wire Size: 2.5 mm2 trailing cable
- Fuse: 20AT- 220V/50Hz
- Strobe Lamp: Standard Xenon (200-250V Power supply)
- Size (without bracket): 245 x 425 x 240 mm - Net Weight : 7.5 kg (16.5 lb)

CODE	MSRP EUR	MSRP GBP
E394E	€285,06	£261.69



LIGHTBLASTER 3000 LAMP - Replacement lamp for Soundsation strobo projector SOUNDSATION LST-3000

Longlasting usage, power 3000 watt

CODE	MSRP EUR	MSRP GBP
L235L	€32,80	£30.11



LIGHTBLASTER 1500 LAMP - Replacement lamp for Soundsation strobo projector SOUNDSATION LST-1500

Longlasting usage, power 1500 watt

CODE	MSRP EUR	MSRP GBP
L234L	€16,21	£14.88



MTR-25-10W-SET - Set of 4x slim 25x10W RGBW blinders with Flight case

Sounsation MTR-25-10W-4IN1 RGBW combines 4IN1 LED technology and modular mechanical design to provide a powerful matrix system and create graphic Pixel-Art effects, to be used as blinders and much more. The set consists of 4 units and a flight case with wheels. The enclosure of each module is equipped with robust and reliable fastening system that allows you to create real LED-walls. The Master/Slave DMX control system allows a maximum of 1, 4 or 16 modules controllable without any software. You just need a DMX controller with an adequate number of channels (see the manual for details). But if you add a PC/DMX interface (not supplied), the potential become enormous, and the limit is established only by the characteristics of the interface and the software used (not supplied). About software, the SOUNDSATION MTR-25-10W-RGBW is compatible with all major packages on the market, such as Emulation Pro Control Software[®] by Elation, DMX Eclipse[™] Software by Blizzard Lighting, Sunlite Suite 2[™] by Nicolaudie, Madrix 3 by Madrix[®], and many others.

- Light source: 25 x 10W RGBW 4in1 High Brightness LED
- Pixel by pixel control, delivering versatile effects
- Coupling system cabinet to create structures with more units
- Flight case to transport 4 units and store accessories
- Control modes: Sound Active, LED Auto Run, DMX Master/slave, ArtNet
- DMX Channel Modes: 1CH, 4CH, 5CH, 25CH, 75CH and 100CH
- Controllable by external controllers or computers (this requires third party equipment)
- Smooth 0-100% dimmer
- Versatile Strobe Effects
- Flicker Free
- LED display interface, easy to control
- LED self test: R, G, B, W, RGBW

- Voltage: AC100-240V 50/60HZ
- Power Consumption: 300W (1 Unit)
- Data In/Out: 3-Pin XLR and RJ45
- Fuse: F5A, 250V
- Unit Size: 58 x 58 x 12cm
- Unit Weight: 13kg



CODE	MSRP EUR	MSRP GBP
L763L	€3.010,10	£2,763.27

MTR-16-30W-SET - Set of 4x slim 16x30W RGB COB blinders with Flight case

Sounsation MTR-16-30W-COB combines 3IN1 COB LED technology and modular mechanical design to provide a powerful matrix system and create graphic Pixel-Art effects, to be used as blinders and much more. The set consists of 4 units and a flight case with wheels. The enclosure of each module is equipped with robust and reliable fastening system that allows you to create real LED-walls. The Master/Slave DMX control system allows a maximum of 1, 4 or 16 modules controllable without any software. You just need a DMX controller with an adequate number of channels (see the manual for details). But if you add a PC/DMX interface (not supplied), the potential become enormous, and the limit is established only by the characteristics of the interface and the software used (not supplied). About software, the SOUNDSATION MTR-25-10W-RGBW is compatible with all major packages on the market, such as Emulation Pro Control Software[®] by Elation, DMX Eclipse[™] Software by Blizzard Lighting, Sunlite Suite 2[™] by Nicolaudie, Madrix 3 by Madrix[®], and many others.

- Light source: 16 x 30W COB RGB 3in1 High Brightness LEDs
- Pixel by pixel control, delivering versatile effects
- Coupling system cabinet to create structures with more units
- Flight case to transport 4 units and store accessories
- Functions: Color mix, automatic color change, built-in program and strobe effect with adjustable speed, dimmer, master/slave
- DMX Channel Modes: 3CH, 4CH, 6CH, 16CH, 18CH, 48CH, 49CH, 50CH, 51CH
- Controllable by external controllers or computers (this requires third party equipment)
- Smooth 0-100% dimmer
- Versatile Strobe Effects
- LED display interface, easy to control
- LED self test: R, G, B, RGB

- Voltage: AC100-240V 50/60HZ
- Power Consumption: 500W (1 Unit)
- Data In/Out: 3-Pin XLR and RJ45
- Unit Size: 47.5 x 47.5 x 13.5cm
- Unit Weight: 11kg

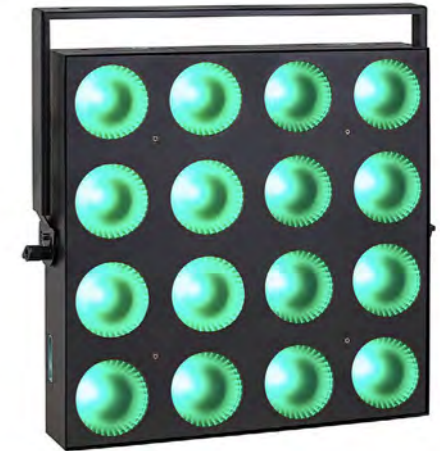

CODE	MSRP EUR	MSRP GBP
L766L	€3.136,84	£2,879.62

4LEDKIT-DJ - 7x3W LED Tricolor 4-PAR Lighting Kit

SOUNDSATION 4LEDKIT-DJ brings you a complete light system including all accessories in only one package. It is the smartest solution for all musicians, DJs, and small rental companies. It comes complete with 4 compact LED spots. Each spot contains 7pcs 3Watt RGB 3in1 LEDs in order to create a complete color palette. The spots are mounted on a T-bar which has a built-in controller unit. The T-bar can be controlled by the included pedal-board or by DMX. In addition to RGB color adjustment of all four PARs independently, the unit features 16 color change auto programs strobo and sound control, to let your lighting kit create wonderful effects even without a DMX controller.

- 4 PARs with 7 high-brightness 3W LED each
- T-Bar with internal controller and power unit (carrying bag included)
- Tripod Stand with carrying bag included
- Operation Modes: Auto, Sound, DMX, Footswitch modes
- 8 Internal Programs, Sound Control and Strobe
- DMX: 16CH, 12CH, 7CH, 3CH and 1CH modes
- Lens Angle: 25° (on each LED)
- LED Display for easy navigation and programming
- Pedalboard with 4 footswitch

- Portable system of 4 PAR lights, built-in power supply and control unit
- Light Source per PAR: 7 RGB 3in1 LED on each PAR (28 LEDs in total)
- Beam angle: 25° (per LED)
- DMX Channels: 1, 3, 7, 12, and 16CH modes
- AC power: 100V-240V 50/60Hz Switching Power Supply
- Power Consumption: 100W max.
- Bar Size: 1170 x 160 x 60 mm
- Bar Weight: 7 kg
- Bar Bag Size: 1270 x 370 x 100 mm
- Bar Bag Weight: 10 kg
- Pedalboard Size: 380 x 60 x 200 mm
- Pedalboard Weight: 1.4 kg
- Tripod Height: 1240 mm (closed), 2240 mm (max.)



CODE	MSRP EUR	MSRP GBP
E261E	€368,14	£337.95

4LEDKIT-PARTY - Complete 4-PAR LED Lighting Kit

SOUNDSATION 4LEDKIT-PARTY brings you a complete light system including all accessories in only one package. It is the smartest solution for all musicians, DJs, and small rental companies. It comes complete with 4 compact LED spots. Each spot contains 81 LEDs (27 Red, 27 Green, 27 Blue) in order to create a complete color palette. The spots are mounted on a T-bar which has a built-in controller unit. The T-bar can be controlled by the included pedal-board or by DMX. In addition to RGB color adjustment of all four PARs independently, the unit features 12 auto running programs and 4 Audio Mode Options, to let your lighting kit create wonderful effects even without a DMX controller.

- 4 PARs with 81 high-brightness LED each (27R, 27G, 27B)
- T-Bar with internal controller and power unit (carrying bag included)
- 2.2m max Tripod Stand with carrying bag included
- Operation Modes: Auto, Sound, DMX, Footswitch modes
- 12 Internal Programs
- DMX: 15CH mode or 3CH basic mode (only RGB control on all PARs)
- 4 kinds of Audio Mode with internal Microphone and sensitivity adjustment
- Beam Angle: 16° (per PAR)
- Field Angle: 26° (per PAR)
- LED Display for easy navigation and programming
- Pedalboard with 2 footswitch

- LED per single PAR: 27 red 625nm/100mW, 27 green 525nm/120mW, 27 blue 465nm/120mW
- Beam angle: 16° (per PAR)
- Field angle: 26° (per PAR)
- DMX Channels: 3, 15CH
- AC power: 100V-240V 50/60Hz Switching Power Supply
- Power Consumption: 30W
- Fuse: 1.6A slow
- Power Linking: 30pcs @ 240V, 15pcs @ 110V
- Bar Size: 910x242x48 mm



CODE	MSRP EUR	MSRP GBP
E226E	€280,37	£257.38



OMEGA-850 PRO - 850mW Professional Graphic Laser with ILDA® and SD-Card

SOUNDSATION OMEGA-850 PRO is a professional Class 4 graphic laser projector based on latest scanning laser light technology. It features high-quality LED RGB laser emitters and fish-eye lens that produce bright laser beams with light angle of almost 180°. LCD control panel assures fast operation, making complex professional laser accessible to everyone. ILDA connection to PC and to other ILDA-standard laser units as well as the SD-Card slot open to users' creativity quite infinite possibilities of use. This laser light is the right choice for all those professionals, light designers and rental companies who need a reliable and versatile instrument for graphic laser effects.

- 850mW RGB graphic laser (200mW R, 150mW G, 500mW B) for complete color palette effects
- 20K scanner speed
- Built-in Fish-eye Lens for 180° emitting radiation Angle
- Lens Magnification: 0.23X
- 3-dimensional adjustment frame for maximum alignment of laser emitters
- Built-in 2 sets of programs and 2 sets of voice programs
- SD-Card reader for quick access to external ILDA libraries
- ILDA standard protocol for maximum compatibility with other ILDA software/hardware equipment
- Operation Modes: ILDA show in SD Card playing, Internal Program playing, Sound, DMX, Master/Slave
- DMX: 24CH mode
- 128x64 dot multi-function LCD display system for quick access to all parameters memory content
- Job wheel with switch for easy menu navigation and editing
- Wired Remote Control Connector for hard-blackout
- Key switch and safety eye for maximum safety of use and installation



- Laser Red: 638nm/200mw
- Laser Green: DPSS 532nm/150mw
- Laser Blue: 450nm/500mw
- Laser Type: Class 4 Laser
- Zoom angle: 1-36°
- Scanner Speed: 20K
- I/O Connectors: (DMX) 3-pin XLR / (ILDA) DB25
- S/D Connectors: Outlay SD card store programs
- DMX: 24CH

- Maximum External Temp: 104°F (40°C)
- Cooling System: Green TEC cooling
- Power Supply Type: Switching (internal)
- Power Range: 100-240V 50/60Hz
- Consumption: 30W
- Fuse: T1.6A 250V
- Unit Dimension (LxHxD): 316x89x154 mm
- Unit Net Weight: 4.26 kg

CODE	MSRP EUR	MSRP GBP
E229E	€918,99	£843.63

OMEGA-330 TEXT - 330mW Text Laser System with RGB Graphic Effects

SOUNDSATION OMEGA-330 TEXT is a new professional laser projector based on state-of-the-art technology. It features high-quality LED RGB laser emitters and 10K professional optical scanner, which produces bright laser beams and smooth patterns. LED panel menu, PS/2 QWERTY keyboard, and the handy remote control make this fixture extremely easy to program and convenient to use. Besides the built-in traditional patterns, there's many operation modes that can be edited. It is the right choice for all those musicians, DJs and small rental companies who need a reliable and versatile instrument for graphic and text-based effects.

- 300mW RGB graphic laser (150mW Red, 80mW Green, 100mW Blue)
- 10K scanner speed
- Operation Modes: Auto, Sound, DMX, Master/Slave, Keyboard modes
- 9 Auto Programs, 9 Sound Programs, 9 Text Programs, 9 Time Mode Programs, Countdown Mode
- DMX: 20CH mode
- QWERTY keyboard for quick text typing and unit control
- IR Remote Controller for quick control
- LED Display for easy navigation and programming
- Wired Remote Control Connector for hard-blackout
- Key switch and safety eye for maximum safety of use and installation



- Laser Class: Class-3B
- Red Laser: LD 650nm, 150mw
- Green Laser: DPSS 532nm, 80mw
- Blue Laser: LD 450nm, 100mw
- Scanner Speed: 10K
- Auto Shows: 9
- Sound Shows: 9

- DMX Channel Range: 1-20
- Mains: 100-240V - 50/60Hz
- Fuse: 250V 1.6 A Slow Blow
- Consumption: 15W
- Fixture Size (WxHxD): 236 x 188 x 194.5 mm
- Fixture Weight: 2.0 kg

CODE	MSRP EUR	MSRP GBP
E227E	€382,94	£351.54

OMEGA-300 RGB - Compact RGB Graphic Laser System

SOUNDSATION OMEGA-300 RGB is a new Class 3B professional graphic laser projector based on state-of-the-art technology. It features high-quality LED RGB laser emitters that produce bright laser beams and smooth patterns. LED panel menu, and the handy remote control make this fixture extremely easy to program and convenient to use. It is the right choice for all those musicians, DJs and small rental companies who need a reliable and versatile instrument for graphic laser effects.

- 300mW RGB graphic laser (150mW R, 50mW G, 100mW B) for complete color palette effects
- 32 Patterns
- 7 Auto Programs
- 7 Sound Programs with internal Microphone and sensitivity adjustment
- Operation Modes: Auto, Sound, DMX, Master/Slave
- DMX: 10CH mode
- IR Remote Controller for quick control
- Key switch and safety eye for maximum safety of use and installation



- Laser Class: Class-3B
- Red Laser: LD 650nm, 150mw
- Green Laser: DPSS 532nm, 50mw
- Blue Laser: LD 450nm, 100mw
- AUTO: Four Auto Shows
- SOUND: Four Sound Shows
- DMX Channel Range: 1-10
- Mains: 100-240V - 50/60Hz
- Fuse: 250V 1A Slow Blow (20mm Glass)
- Consumption: 20W
- Fixture Size (WxHxD): 200 x 80 x 145.5 mm
- Fixture Weight: 1.5 kg

CODE	MSRP EUR	MSRP GBP
E228E	€266,90	£245.01

LSR2 - 2 Color Mini Laser

Compact bi-color effect laser easy to use and lightweight to carry. It is perfect for DJ, club, private party or anniversary. The unit is able to project a dynamic set of points and lines through red and green moving laser beams thus creating amazing effects. Setting the SOUND mode the LSR2 will automatically work according to music of the ambience and dynamically adjusting effects. The onboard stroboflash function is available. It comes with a very useful mounting bracket and a tripod for desktop positioning.

- Laser power : Red 100mW (532nm), Green 50mW (650nm)
- Control mode : auto / sound mode with built-in microphone
- User adjustable stroboflash function
- It comes with mounting bracket and desktop tripod

- Power requirements : 5Vcc, power adaptor included
- Power adaptor: Input 110-240Vac / 50-60Hz - Output 5Vcc / 1A
- Unit dimension: 130 x 92 x 52 mm
- Unit net weight: 0,28 kg



CODE	MSRP EUR	MSRP GBP
L153L	€48,15	£44.20

ILDA100-5 - 5m extension cable for ILDA Devices

DB25 Male - DB25 Female, 5m extension cable for ILDA Devices

- Length: 5m
- Color: Black



CODE	MSRP EUR	MSRP GBP
E230E	€28,03	£25.73

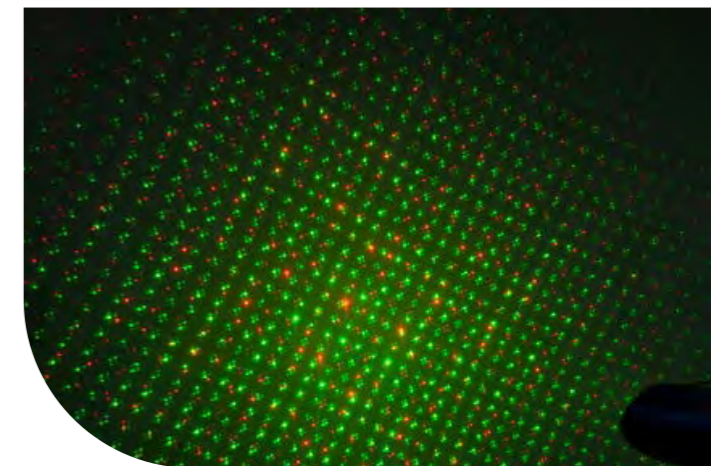

SC-30W-1 - 30W RGB COB LED scanner with 9+1 gobos

SC-30W-1 is a professional lightweight scanner able to create beautiful and powerful lighting effects thanks to the high-brightness, long-life 30W RGB COB LED and the 9 high-quality gobos. The 7CH or 9CH Master/Slave DMX control or the Auto and Sound modes allows the SC-30W-1 to be used in a wide range of different applications: disco dance halls, clubs, pubs, bars, mobile DJ, etc.

- LED source: 1pc high-brightness, long-life 30W RGB COB LED
- 9+1 gobos + RGB color + spot, colorful changeable effects
- Built-in Master/Slave, Sound Active modes and Show mode
- DMX Control: 7 / 9 CH modes
- LED display, easy to set up
- Control modes: Sound active, Auto run, Show Mode, DMX Master / Slave
- Eyelet for safety rope
- Suitable for disco dance hall, club, bar, party, mobile DJ and so on

- Voltage: AC100-240V, 50-60Hz
- Fuse: T3A - 250V
- Power consumption: 50W
- Fixture dimension (WxHxD): 375 x 175 x 150 mm (excl. bracket)
- Net weight: 3.4 kg



CODE	MSRP EUR	MSRP GBP
L415L	€246,52	£226.31

INDOOR LED BARS & WASHERS

CLUB LINER 93 RGB - 8pcs 3W RGB 3IN1 Mini LED Bar

CLUB LINER 93 RGB is a mini LED bar specifically designed for all applications where silence is required. It has a fanless cooling system that, while ensuring heat dissipation, reduces to zero noise emission. The bar, about 410mm long, comes with 8pcs 3W RGB 3in1 LEDs, 9CH and 4CH DMX control, and a longitudinal array bar system that allows you to build multiple-length arrays. Beam angle is 120°.

- Lighting Source: 8pcs 3W RGB 3in1 LEDs
- Beam Angle: 120°
- Operative Modes: DMX, Master/Slave, Sound, Auto
- DMX Control: 4CH/9CH
- Dimmer: 0~100% linear with 5 selectable curves
- Strobe: 0-20Hz

- Voltage: 110V ~ 240V (switching Power Supply)
- Power Consumption: 25W
- LED: 8x3W (RGB 3in 1)
- Beam Angle: 120° reflector
- Bar Size (LxHxD): 414.6x116.5x80mm
- Bar Size: 0.75kg



CODE	MSRP EUR	MSRP GBP
E257E	€74,25	£68.16

CLUB LINER 93 UV - 9pcs 3W UV Mini LED Bar

CLUB LINER 93 UV is a mini UV LED bar specifically designed for all applications where silence is required. It has a fanless cooling system that, while ensuring heat dissipation, reduces to zero noise emission. The bar, about 410mm long, comes with 9pcs 3W UV LEDs, 3CH and 1CH DMX control modes, and a longitudinal array bar system that allows you to build multiple-length arrays. Beam angle is 110°.

- Lighting Source: 9pcs 3W UV LEDs
- Beam Angle: 110°
- Operative Modes: DMX, Master/Slave, Sound, Auto
- DMX Control: 1CH/3CH

- Voltage: 110V ~ 240V (switching Power Supply)
- Power Consumption: 25W
- LED: 9x3W UV
- Life span: around 50,000 hours



CODE	MSRP EUR	MSRP GBP
E258E	€64,57	£59.28



MBL-5-18W-6IN1 - 5x18W RGBWA+UV 6IN1 LED Magic Ball

Evergreen queen of the 70s disco, unmatched by any other lighting effect in the history of lighting applied to entertainment, the Magic Ball is once more introduced with all the advantages of LED technology. MBL-5-18W-6IN1 is a rotating ball with remotely-controlled rotation speed and 5 x 18w LEDs with 6in1 technology, the combination of which allows you to create the typical atmospheres of the '70 clubs yet integrating the colorful effects of LEDs. DMX control is 3 or 11 channels. Control modes are Sound, DMX Master/Slave, and Automatic.

- Light source: 5pcs 18W RGBWA+UV 6in1 LEDs
- Built-in master-slave, sound control, and show mode.
- LED display, easy to control
- Suitable for indoor venues like disco, club, bar, party and DJ moving show
- DMX Channel Modes: 3CH and 11CH
- 4 Operation Mode: Sound test, Auto run, DMX and Master/slave

- Voltage: AC100-240V, 50/60Hz
- Power Consumption: 65W
- Fuse: F3A, L250V
- Light size (WxHxD): 30 x 30 x 38 cm
- Weight: 4.1 kg



CODE	MSRP EUR	MSRP GBP
L750L	€258,03	£236.87

SCENEMAKER SERIES

SCENEMAKER SERIES

SCENE MAKER 6 Compact 6-Channel DMX Controller

SCENEMAKER 6 is a professional 6-channel DMX controller with 6 faders to control DMX channels 1 to 6. There is also a master fader as overall level. It is very compact, portable, and easy to operate for users.

- Protocol: DMX-512 USITT
- DMX Channels: 1 to 6
- Data Output: Locking 3-pin XLR female socket
- Data Pin Configuration: Pin 1 shield, Pin 2 (-), Pin 3 (+)
- Power Supply: DC 9V-12V, 1000 mA min.
- Controller Size (WxHxD): 180x55x135 mm
- Net Weight 0.7 kg



CODE	MSRP EUR	MSRP GBP
E063E	€51,32	£47.11

SCENE MAKER 12/16 DMX512 Lighting Controller

SCENEMAKER 1216 is a universal intelligent lighting controller. It allows you to manage up to 12 fixtures composed of 16 channels each (192 channels in total), and up to 184 programmable scenes. Six chases can contain up to 184 steps composed by the saved scenes (the steps) and in any order. Programs can be triggered by music, MIDI, automatically or manually. Its control surface hosts various programming tools such as 8 universal channel sliders, quick access scanner and scene buttons, as well as a LED display for easier navigation of controls and menu functions.

- 12 Fixtures with 16 DMX Channels each; 192 Channels in total
- 23 banks of 8 programmable scenes, 184 scenes total
- 6 chases of 184 programmed scenes from 23 banks
- Execute multiple chases simultaneously
- 8 Sliders x 2 Pages for direct control of channels
- Auto Mode controlled by Speed and Fade Time
- 8-CH / 16-CH modes for Assigned or Reversed DMX channels
- Master Blackout
- Built-in microphone for music triggering
- USB connection for LED Goose-neck Lamp (Not included)
- LED Display for easy navigation of menus
- MIDI control over banks, chases and Blackout



- Power Supply: DC 9V-12V, 500mA min.
- USB Lamp (not included): 5V - 200 mA max
- Protocols: DMX-512 USITT
- Data Input: Locking 3-pin XLR male socket
- Data Output: Locking 3-pin XLR female socket
- Data Pin Configuration: Pin 1 shield, Pin 2 (-), Pin 3 (+)
- Controller Size (WxHxD): 482x82x133 mm
- Net Weight 2.0 kg

CODE	MSRP EUR	MSRP GBP
E064E	€85,46	£78.45

SCENE MAKER 24/16 24 Fixtures x 16 Channels DMX Intelligent Lighting Controller

SCENEMAKER 2416 is a universal intelligent lighting controller. It allows you to manage up to 24 fixtures composed of 16 channels each (384 channels in total), and up to 240 programmable scenes. 6 chases can contain up to 240 steps composed by the saved scenes (the steps) and in any order. Programs can be triggered by music, MIDI, automatically or manually. On the surface you will find various programming tools such as 16 universal channel sliders, quick access scanner and scene buttons, and a LED display indicator for easier navigation of controls and menu functions.

- 24 Fixtures with 16 DMX Channels each; 384 Channels in total
- 30 banks of 8 programmable scenes, 240 scenes total
- 6 chases of 240 programmed scenes from 30 bank
- Executes multiple chases simultaneously
- 16 Sliders for direct control of channels
- Auto Mode controlled by Speed and Fade Time
- Master Blackout
- Built-in microphone for Music triggering
- USB LED Goose-neck Lamp
- LED Display for easy navigation of menus
- MIDI control over banks, chases and Blackout
- Plastic end housing

- Power Supply: DC 9V-12V, 500mA min.
- USB Lamp: 5V - 200 mA max
- Protocols: DMX-512 USITT
- Data Input: locking 3-pin XLR male socket
- Data Output: locking 3-pin XLR female socket
- Data Pin Configuration: Pin 1 shield, Pin 2 (-), Pin 3 (+)
- Controller Size (WxHxD): 520 x 73 x 183 mm - Net Weight 2.7 kg



CODE	MSRP EUR	MSRP GBP
E066E	€200,51	£184.07

SCENE SPLIT 6 TRUSS

1 Input / 6 Outputs DMX Distributor

SCENESPLIT 6 TRUSS is a professional 1IN - 6OUTs DMX distributor whose housing design has been specifically made to be installed on trusses or other stage infrastructures. The quality of its components and internal circuitry makes it ideal for high-grade stage applications.

- Separate high voltage protection on each Outputs
- High quality power supply stage for maximum stability at wider range voltage input (from 88Ac to 256Vac)
- High quality Fairchild® optical coupler for maximum isolation
- Golden plated XLR Connector for improved conductivity

- Power Input: AC88 ~ 256Vac 50/60Hz
- Fuse: F1A - 250V
- Protocols: DMX-512
- Data Input/Outputs: 3-pin XLR male (In) female (out) sockets
- Data Pin Configuration: Pin 1 shield, Pin 2 (-), Pin 3 (+)
- Distributor Size (WxHxD): 186 x 124 x 128 mm
- Net Weight: 0.85 kg



CODE	MSRP EUR	MSRP GBP
E067E	€144,62	£132.76

SCENE SPLIT 8 RACK

1 Input / 8 Outputs DMX Distributor, 1 rack unit

SCENESPLIT 8 RACK is a professional 1IN - 8OUTs DMX distributor, 1 19" rack unit. The quality of its components and internal circuitry makes it ideal for high-grade stage applications.

- Separate high voltage protection on each Outputs
- High quality power supply stage for maximum stability at wider range voltage input (from 88Ac to 256Vac)
- High quality Fairchild® optical coupler for maximum isolation
- Golden plated XLR Connector for improved conductivity

- Power Input: AC88 ~ 256Vac 50/60Hz
- Fuse: F1A - 250V
- Protocols: DMX-512
- Data Input/Outputs: 3-pin XLR male (In) female (out) sockets
- Data Pin Configuration: Pin 1 shield, Pin 2 (-), Pin 3 (+)
- Distributor Size (WxHxD): 482 x 46 x 118 mm
- Net Weight: 1.35 kg



CODE	MSRP EUR	MSRP GBP
E068E	€162,71	£149.37

AIRCORN 126 - 2.4 GHz 126 Channel Wireless DMX Unit

Aircorn 126 transmits and receives standard DMX 512 protocol data by wireless way, which solve lighting control issues of wireless communication between lighting controllers and fixtures. It gets rid of relying on connecting cables completely, and also can ensure without any time delay when signal data is real time and reliable. It adopts global free 2.4GHz ISM frequency band and high effective GFSK modulation. Communication design is in 126 channels jumping frequency with high anti-jamming ability. The product is therefore applied in many contexts, such as stage lighting disco hall, gymnasium lighting, portable stage performance, conference centers, theme parks, bar lighting, and so on. In short, a really useful tool to solve DMX connection problems quickly.

- Both Transmitting and Receiving operation within same unit
- One transmitter can manage more receivers at the same time
- 7 groups ID code set table, User can use 7 groups individual wireless nets without any interfere each other in the same place
- Each net contains 512 DMX channels
- 126 channels jumping frequency (7 groups x 16 channel frequencies) to avoid interferences

- High anti-jamming ability to ensure working reliability
- Work frequency range: 2.4 GHz ISM band (no license needed)
- Communication distance: 300 m
- Tricolor LED displaying for easy setup
- High quality power supply stage for maximum stability at wider range voltage input

- Frequency Band: 2.4 GHz ISM
- Modulation Type: GFSK Modulation
- Frequency range: 24,000 ~ 24,835 GHz
- Channel Frequencies: 126 jumping frequencies
- Communication Distance: 300 m
- Receiver Sensibility: -106 dBm
- Transmission Power: 20 dBm
- Antenna: 100 mm helical SMA antenna
- Protocols: DMX512
- Number of DMX Channels: 512 Channels within each ID
- Power Input: AC88 ~ 256 Vac - 50/60 Hz
- Data Input/Outputs: 3-pin XLR male (In) female (out) sockets
- Data Pin Configuration: Pin 1 shield, Pin 2 (-), Pin 3 (+)
- Unit Size (WxHxD): 150x50x76 mm
- Unit Net Weight 0.27 kg

CODE	MSRP EUR	MSRP GBP
E089E	€88,74	£81.46



SPBX-4X3M - RJ45 DMX Split Box with 4 Male XLR channels multi-core system

SPBX-4X3M is a DMX split box with RJ45 EtherCON connector and 4 multi-core system XLR channels. It requires shielded SFTP CAT5e/CAT6 as a connection cable, to ensure optimal conductor insulation. The 4 channels share the same ground. It can also be used for transmitting analogue or AES/EBU audio signals.

- RJ45 socket: Neutrik EtherCON NE8FAH
- 4 Male XLR connectors
- Audio Transmission: analogue or AES/EBU
- Required Connection Cable: SFTP CAT5e/CAT6

CODE	MSRP EUR	MSRP GBP
L875L	€29,90	£27.45



SPBX-4X3F - RJ45 DMX Split Box with 4 Female XLR channels multi-core system

SPBX-4X3M is a DMX split box with RJ45 EtherCON connector and 4 multi-core system XLR channels. It requires shielded SFTP CAT5e/CAT6 as a connection cable, to ensure optimal conductor insulation. The 4 channels share the same ground. It can also be used for transmitting analogue or AES/EBU audio signals.

- RJ45 socket: Neutrik EtherCON NE8FAH
- 4 Female XLR connectors
- Audio Transmission: analogue or AES/EBU
- Required Connection Cable: SFTP CAT5e/CAT6

CODE	MSRP EUR	MSRP GBP
L876L	€30,43	£27.93



ZEPHIRO 2000ST HAZE - Powerful Haze Machine with adjustable output and speed, DMX control and Onboard LCD Display.

ZEPHIRO 2000ST HAZE is a powerful 2000 Watt haze machine with DMX interface. This device, with its continuous haze emission, is a good support for lighting. It can be used in many fields of application to create subtle atmospheres and to improve the visual effects of light beams on dance floors, in concerts and more.

- 280m³/Minute haze output fills up a very large sized room quickly.
- Continuous haze output after a minimal warm-up time.
- Adjustable Haze output, blower speed and DMX channels.
- Easy setting of internal parameters by using the control panel and LCD display.
- Bundled sturdy Flight-case to help the transport and installation.

- Heating element: 2000 Watt
- Warm-up time: Approximately 1,5 Min
- Tank capacity: 5 Liters
- Haze Output: 280m³/Min
- Liquid consumption: 320 Min/L (30%) - 200 Min/L (100%)
- Control Panel: Yes (6 buttons with LCD display 2x8 Characters)
- DMX connectivity: YES(3/5 pin)
- DMX controls: 2 Channels (Fan Speed, Output Haze Volume)
- Flight-case: Included
- Power requirements: 220V AC, 50Hz
- Internal fuse: 10A 250V fast blow 20mm glass
- Dimensions: 600 x 390 x 280 mm - Weight: 16 Kg



CODE	MSRP EUR	MSRP GBP
E409E	€855,98	£785.79

ZEPHIRO 1000ST HAZE - Powerful Haze Machine with adjustable output and speed, DMX control and Onboard LCD Display.

ZEPHIRO 1000ST HAZE is a powerful 2000 Watt haze machine with DMX interface. This device, with its continuous haze emission, is a good support for lighting. It can be used in many fields of application to create subtle atmospheres and to improve the visual effects of light beams on dance floors, in concerts and more.

- 170m³/Minute haze output fills up a very large sized room quickly.
- Continuous haze output after a minimal warm-up time.
- Adjustable Haze output, blower speed and DMX channels.
- Easy setting of internal parameters by using the control panel and LCD display.
- Bundled sturdy Flight-case to help the transport and installation.

- Heating element: 1000 Watt
- Warm-up time: Approximately 1,5 Min
- Tank capacity: 2 Liters
- Haze Output: 170m³/Min
- Liquid consumption: 200 Min/L (30%) - 120 Min/L (100%)
- Control Panel: Yes (6 buttons with LCD display 2x8 Characters)
- DMX connectivity: YES (3/5 pin)
- DMX controls: 2 Channels (Fan Speed, Output Haze Volume)
- Flight-case: Included
- Power requirements: 220V AC, 50Hz
- Internal fuse: 10A 250V fast blow 20mm glass
- Dimensions: 440 x 215 x 395 mm - Weight: 12 Kg



CODE	MSRP EUR	MSRP GBP
E411E	€503,32	£462.05

ZEPHIRO 3000 FOG - Powerful smoke machine with DMX interface, wired and wireless controllers.

ZEPHIRO 3000 FOG is a professional smoke machine, suitable for big size environments as discos, theatre, indoor events where a powerful ambient effect with great fogging volume is required.

- 710m³/Minute smoke output fills up a medium sized room quickly.
- Continuous smoke output after a minimal warm-up time.
- One Selectable DMX Channel to control smoke volume emission.
- Wired Controller to manage Timer, Duration Fog Emission and Volume Fog Emission.
- Remote controller to start and stop the smoke emission.

- Heating Element: 3000 Watt
- Output distance: 8-10 meters
- Warm-up time: Approximately 4 Minutes
- Tank capacity: 10 Liters
- Fog output: 710m³/Min
- Fuel Consumption: about 2L/hour (depending on liquid density)
- Ready-indicator inside tank: Yes (Dual color LED)
- Wireless remote controller included: Yes - 433,92 MHz (Max 10 Meters)
- Wired remote controller included: Yes (Timer, Manual smoke, Continuous fog)
- DMX Control: Yes (One Channel)
- Mounting bracket included: Yes
- Power requirements: 220V AC, 50Hz
- Internal fuse: 10A 250V fast blow 20mm glass
- Dimensions: 680 x 250 x 330 mm

CODE	MSRP EUR	MSRP GBP
E412E	€328,69	£301.74



ZEPHIRO 1500MA FOG - Powerful Fog machine with adjustable output, DMX interface, wired control and remote control.

ZEPHIRO 1500MA FOG is a professional Fog machine with a manually adjustable output, suitable for middle size environments as discos, theatre, indoor events where a powerful ambient effect with great fogging volume is required.

- 566m³/Minute Fog output fills up a medium sized room quickly.
- Continuous fog output after a minimal warm-up time.
- Manually adjustable fog output angle of 180°
- One Selectable DMX Channel to control fog volume emission.
- Wired Controller to manage Timer, Duration Fog Emission and Volume Fog Emission.



- Heating Element: 1500 Watt
- Output distance: 4-5 meters
- Warm-up time: Approximately 3 Minutes
- Tank capacity: 2,5 Liters
- Fog output: 566m³/Min
- Orientation Angle: 180°
- Ready-indicator inside tank: Yes (Dual color LED)
- Wireless remote controller included: Yes - 433,92 MHz (Max 10 Meters)
- Wired remote controller included: Yes (Timer, Manual fog, Continuous fog)
- DMX Control: Yes (One Channel)
- Mounting bracket included: Yes
- Power requirements: 220V AC, 50Hz
- Internal fuse: 10A - 250V fast blow 20mm glass
- Dimensions: 550 x 310 x 290 mm - Weight: 7,3Kg

CODE	MSRP EUR	MSRP GBP
E413E	€264,64	£242.94

ZEPHIRO 1500 FOG - Powerful Fog machine with DMX interface, wired and wireless controllers.

ZEPHIRO 1500 FOG is a professional Fog machine, suitable for middle size environments as discos, theatre, indoor events where a powerful ambient effect with great fogging volume is required.

- 566m³/Minute Fog output fills up a medium sized room quickly.
- Continuous fog output after a minimal warm-up time.
- One Selectable DMX Channel to control fog volume emission.
- Wired Controller to manage Timer, Duration Fog Emission and Volume Fog Emission.
- Remote controller to start and stop the fog emission.



- Heating Element: 1500 Watt
- Output distance: 4-5 meters
- Warm-up time: Approximately 3 Minutes
- Tank capacity: 2,5 Liters
- Fog output: 566m³/Min
- Ready-indicator inside tank: Yes (Dual color LED)
- Wireless remote controller included: Yes - 433,92 MHz (Max 10 Meters)
- Wired remote controller included: Yes (Timer, Manual fog, Continuous fog)
- DMX Control: Yes (One Channel)
- Mounting bracket included: Yes
- Power requirements: 220V AC, 50Hz
- Internal fuse: 10A 250V fast blow 20mm glass
- Dimensions: 470 x 255 x 190 mm - Weight: 5,5Kg

CODE	MSRP EUR	MSRP GBP
E414E	€168,29	£154.49

ZEPHIRO 1200 FOG - Powerful Fog machine with wired and wireless controllers.

ZEPHIRO 1200 FOG is a compact and lightweight fog machine, suitable for medium-sized environments where a fog effect is required to enhance any light show.

- 453m³/Minute Fog output fills up a medium sized room quickly.
- Continuous fog output after a minimal warm-up time.
- Wired Controller to start and stop the fog emission.
- Remote controller to start and stop the fog emission without connection cables.



- Heating Element: 1200 Watt
- Output distance: 4-5 meters
- Warm-up time: Approximately 3 Minutes
- Tank capacity: 2,5 Liters
- Fog output: 453m³/Min
- Wireless remote controller included: Yes - 433,92 MHz (Max 10 Meters)
- Wired remote controller included: Yes (START/STOP Switch)
- Mounting bracket included: Yes
- Power requirements: 220V AC, 50Hz
- Internal fuse: 10A 250V fast blow 20mm glass
- Dimensions: 470 x 255 x 190 mm - Weight: 5,5Kg

CODE	MSRP EUR	MSRP GBP
E415E	€101,28	£92,98

ZEPHIRO 400 FOG - Compact and lightweight fog machine with wired and wireless controllers.

ZEPHIRO 400 FOG is a compact and lightweight fog machine, suitable for small sized environments where a fog effect is required to enhance any light show.

- 30m³/Minute Fog output fills up a small sized room quickly.
- Continuous fog output after a minimal warm-up time.
- Wired Controller to start and stop the fog emission.
- Remote controller to start and stop the fog emission without connection cables.

- Heating Element: 400 Watt
- Output distance: 1-2 meters
- Warm-up time: Approximately 3 Minutes
- Tank capacity: 0,25 Liters
- Fog output: 30m³/Min
- Wireless remote controller included: Yes - 433,92 MHz (Max 10 Meters)
- Wired remote controller included: Yes (START/STOP Switch)
- Mounting bracket included: Yes
- Power requirements: 220V AC, 50Hz
- Internal fuse: 10A 250V fast blow 20mm glass
- Dimensions: 240 x 159,5 x 120 mm - Weight: 1,5Kg

CODE	MSRP EUR	MSRP GBP
E418E	€46,49	£42,68



ZEPHIRO 900 FOG - Compact and lightweight fog machine with wired and wireless controllers.

ZEPHIRO 900 FOG is a compact and lightweight fog machine, suitable for medium-small sized environments where a fog effect is required to enhance any light show.

- 140m³/Minute Fog output fills up a medium-small sized room quickly.
- Continuous fog output after a minimal warm-up time.
- Wired Controller to start and stop the fog emission.
- Remote controller to start and stop the fog emission without connection cables.



- Heating Element: 900 Watt
- Output distance: 2-3 meters
- Warm-up time: Approximately 3 Minutes
- Tank capacity: 1 Liter
- Fog output: 140m³/Min
- Wireless remote controller included: Yes - 433,92 MHz (Max 10 Meters)
- Wired remote controller included: Yes (START/STOP Switch)
- Mounting bracket included: Yes
- Power requirements: 220V AC, 50Hz
- Internal fuse: 10A 250V fast blow 20mm glass
- Dimensions: 345 x 205 x 185 mm - Weight: 3,4Kg

CODE	MSRP EUR	MSRP GBP
E416E	€77,31	£70,97

ZEPHIRO 400 FLAME - ZEPHIRO 400 FLAME - 400 Watt Fog Machine with 4 amber LEDs and wireless control

ZEPHIRO 400FLAME is a powerful 400 Watt mini smoke machine with amber LED light that creates an impressive and unique flame effect during smoke output. It can be operated by a supplied manual controller and there is also an external receiver bundled to operate the machine remotely, free from connection cables, via a small remote control. It can be placed on a shelf or on the floor and also on trusses through the supplied mounting bracket that allows it to be fixed. ZEPHIRO 400FLAME is able to generate a smoke volume of 30 m³ /min thanks to its 400 Watt heating system, pump and a tank (0,25L)

- 30m³/Minute Fog output fills up a small sized room quickly.
- Continuous fog output after a minimal warm-up time.
- 4 Amber LEDs light that creates an impressive and unique flame effect during smoke output.
- Wired Controller to start and stop the fog emission.
- Remote controller to start and stop the fog emission without connection cables.

- Heating element: 400 Watt
- LEDs: 4 Amber x 1W
- Output distance: 1-2 meters
- Warm-up time: Approximately 3 Minutes
- Tank capacity: 0,25 Liters
- Fog output: 30 m³ per minute
- Wireless remote controller included: Yes - 433,92 MHz (Max 10 Meters)
- Wired remote controller included: Yes (START/STOP Switch)
- Mounting bracket included: Yes
- Power requirements 220V AC, 50Hz
- Internal fuse: 10A 250V fast blow 20mm glass
- Dimensions(WxDxH): 240 x 159,5 x 120 mm - Weight: 1.5 kg



CODE	MSRP EUR	MSRP GBP
E866E	€60,95	£55,95

ZEPHIRO 1500 LOW FOG - Powerful machine for ground fog effect with DMX interface and wireless controller.

ZEPHIRO 1500 FOG is a professional Ground Fog machine suitable for enhancing dance floors, stages and other environments where the ground fog effect is required.



- 283m³/Minute Fog output fills up a 60m² area quickly.
- Continuous fog output after a minimal warm-up time.
- One Selectable DMX Channel to control fog volume emission.
- Remote controller to start and stop the fog emission.

- Heating Element: 1500 Watt
- Warm-up time: Approximately 4 Minutes
- Tank capacity: 2,3 Liters
- Fog output: 283m³/Min
- Coverage Area: 60m²
- Wireless remote controller included: Yes - 433,92 MHz (Max 10 Meters)
- DMX Control: Yes (One Channel)
- Power requirements: 220V AC, 50Hz
- Internal fuse: 10A 250V fast blow 20mm glass
- Dimensions: 765 x 395 x 415 mm - Weight: 17,4 Kg

CODE	MSRP EUR	MSRP GBP
E419E	€327,26	£300,42

ZEPHIRO 700 LOW FOG - Compact machine for ground fog effect with wired and wireless controllers.

ZEPHIRO 700 FOG is a professional Ground Fog machine suitable for enhancing dance floors, stages and other environments where the ground fog effect is required.



- 170m³/Minute Fog output fills up a 30m² area quickly.
- Continuous fog output after a minimal warm-up time.
- Wired remote controller included: Yes (Timer, Manual fog, Continuous fog)
- Remote controller to start and stop the fog emission.

- Heating Element: 700 Watt
- Warm-up time: Approximately 3 Minutes
- Tank capacity: 1 Liter
- Fog output: 170m³/Min
- Coverage Area: 30m²
- Wired remote controller included: Yes (Timer, Manual fog, Continuous fog)
- Wireless remote controller included: Yes - 433,92 MHz (Max 10 Meters)
- Power requirements: 220V AC, 50Hz
- Internal fuse: 10A 250V fast blow 20mm glass
- Dimensions: 515 x 335 x 270 mm - Weight: 9 Kg

CODE	MSRP EUR	MSRP GBP
E420E	€205,43	£188,58

ZEPHIRO 300 BUBBLE - Professional two-wheeled bubble machine with wireless control

ZEPHIRO 300 BUBBLE is a professional bubble machine that covers small to medium environments with this fun effect.

- A bubbles emission of 2400 bubbles/minute allows the coverage of medium-small size environments.
- Double front and rear fan.
- Double wheel with bubble wands.
- Remote controller to start and stop the bubbles emission.



- Consumption: 300 Watt Bubbles quantity: 2400 per minute
- Coverage Area: 40m²
- Tank Capacity: 2 Liters
- Wireless remote controller included: Yes - 433,92 MHz (Max 10 Meters)
- Power Requirements: 220V AC, 50Hz
- Internal Fuse: 10A 250V fast blow 20mm glass
- Dimensions: 390 x 447 x 470 mm
- Weight: 9,7 Kg - Packing Size: 410 x 450 x 470 mm

CODE	MSRP EUR	MSRP GBP
E421E	€109,56	£100.58

ZEPHIRO 600 SNOW - High efficiency Snow Machine with wired controller.

ZEPHIRO 600 SNOW is a high efficiency snow machine able to cover a medium-sized environment with the snowflakes effect.

- Continuous snowflakes emission able to cover an area of over 30m²
- Wired Controller to start and stop the snow emission.

- Power Consumption: 600 Watt
- Tank Capacity: 1 Liter
- Coverage Area: 30m²
- Wired remote controller included: Yes (START/STOP Switch)
- Mounting Bracket included: YES
- Power requirements: 220V AC, 50Hz
- Internal Fuse: 10A 250V fast blow 20mm glass
- Dimensions: 405 x 245 x 225 mm - Weight: 3,1 Kg

CODE	MSRP EUR	MSRP GBP
E424E	€82,17	£75.43



ZEPHIRO 100 BUBBLE - Compact and lightweight bubbles machine with wireless control

ZEPHIRO 100 BUBBLE is a compact and lightweight bubbles machine that covers small environments with this fun effect.

- A bubbles emission of 500 bubbles/minute allows the coverage of small size environments.
- One wheel with bubble wands.
- Remote controller to start and stop the bubbles emission.



- Consumption: 60 Watt Bubbles quantity:
- Coverage Area: 25m²
- Tank Capacity: 0,75 Liters
- Wireless remote controller included: Yes - 433,92 MHz (Max 10 Meters)
- Power Requirements: 220V AC, 50Hz
- Internal Fuse: 10A 250V fast blow 20mm glass
- Dimensions: 250 x 230 x 230 mm
- Weight: 1,26 Kg - Packing Size: 250 x 240 x 250 mm

CODE	MSRP EUR	MSRP GBP
E422E	€33,28	£30.55

ZEPHIRO 1250 SNOW - 1250 Watt Snow Machine with wired and wireless control

ZEPHIRO 1250 SNOW is a powerful 1250 Watt snow machine that can be operated by a supplied manual or remote controller. It can be placed on a shelf or on the floor and also on trusses through the supplied mounting bracket that allows it to be fixed. It is an excellent choice for use in large disco clubs, professional stage performances etc. ZEPHIRO 1250 SNOW is able to generate snow effect to cover an area of 50/60m² thanks its 1250 Watt power system including a powerful pump.

- Power consumption: 1250 Watt
- Tank capacity: 5 Liter
- Coverage Area: 50-60 m²
- Wired remote controller included
- Wireless remote controller included
- Mounting bracket included

- Power consumption: 1250 Watt
- Tank capacity: 5 Liter
- Coverage Area: 50-60 m²
- Wired remote controller: START/STOP Switch / Snow Flow Control Knob
- Wireless remote controller: START / STOP / Increase Snow Flow / Decrease Snow Flow
- Mounting bracket included
- Power requirements: 220V AC, 50Hz
- Internal fuse: 10A - 250V fast blow 20mm glass
- Dimensions: 520 x 250x 280 mm
- Weight: 7,2 kg
- Packing Size: 580 x 330 x 350 mm
- Packing Weight: 8,7 kg

CODE	MSRP EUR	MSRP GBP
E423E	€130,80	£120.07



SFLD05L - Light Density Smoke Fluid

SOUNDSATION SFLD05L Low Density Fluid is a water-based smoke fluid compatible with any smoke machine equipped with a heater block. Its density is light and the dissipation is rapid. It is designed to create an extremely light but enveloping smoke. The pale blue color is pleasant and leaves no traces of any kind on clothes or surfaces, while the smoke produced is light white. The scent is neutral and pleasant, and leaves no trace after the dissolution. You can also add one of the many SOUNDSATION fragrances to recreate atmospheres that can range from tropical fruits, flowers and fragrant plants. The SFLD05L is made according to strict production processes and strict controls during all its phases, and meets all the European regulatory requirements. It is available in 5L tanks.

- Dispersion: Quick
- Density: Low
- Color: Pale Blue
- For Bright White
- Scent: Neutral
- Package: 5L Tank

CODE	MSRP EUR	MSRP GBP
E824E	€10,98	£10.08



SFMD05L - Medium Density Smoke Fluid

SOUNDSATION SFMD05L Medium Density Fluid is a universal water-based smoke fluid made to be used with most of the smoke machines equipped with heater block. Its density and dissipation are set up to assure a perfect result in all standard applications. The pale blue color is pleasant and leaves no traces of any kind on clothes or surfaces, while the smoke produced is white. The scent is neutral and pleasant, and leaves no trace after the dissolution. It is also possible to add one of the many SOUNDSATION fragrances to recreate sweetness that range from tropical fruit to flowers and fragrant plants. The SFMD05L is made according to strict process of production and a permanent control during the whole manufacturing, and complies with all the European regulatory requirements. It is available in 5L tanks.

- Dispersion: Medium Disperion
- Density: Medium
- Color: Bright Blue
- For White
- Scent: Neutral
- Package: 5L Tank

CODE	MSRP EUR	MSRP GBP
E825E	€13,82	£12.69



SFHD05L - High Density Smoke Fluid

SOUNDSATION SFHD05L High Density Fluid is a water-based smoke fluid suitable for any smoke machine equipped with a heater block. Its density is definitely high; the dispersion is slow, and its stability is very good. It is a product ideal for creating a dense smoke, and designed for effects with considerable persistence. The dark blue color is pleasant and leaves no traces of any kind on clothes or surfaces, while the smoke produced is deep white. The scent is neutral and pleasant, and leaves no trace after the dissolution. You can also add one of the many SOUNDSATION fragrances to recreate atmospheres that can range from tropical fruits, flowers and fragrant plants. The SFHD05L is made according to strict production processes and strict controls during all its phases, and meets all the European regulatory requirements. It is available in 5L tanks.

- Dispersion: Slow
- Density: Alta
- Color: Dark Blue
- For Deep White
- Scent: Neutral
- Package: 5L Tank

CODE	MSRP EUR	MSRP GBP
E826E	€17,03	£15.63



LFSD05L - Medium Density Low-Fog Fluid

SOUNDSATION LFSD05L Low Smoke Fluid is a water-based fluid suitable for any type of low-smoke machine. Its special formulation is designed to be a thick and heavy smoke. It makes the typical “thriller” effect - characteristic of horror films - or of marine and lake environments where the heat transfer at night creates low-smoke effects. Stability is good and persistent. The pale purple color is pleasant and leaves no traces of any kind on clothes or surfaces while the smoke is opaque white. No trace after the dissolution. SOUNDSATION fragrances to recreate atmospheres from tropical fruits, flowers and fragrant plants. The LFSD05L is manufactured according to strict production processes and strict controls during all its phases, and meets the European regulatory requirements. It is available in 5 liter tanks.

- Dispersion: Slow
- Density: Medium
- Color: Pale Purple
- For Opaque White
- Scent: Neutral
- Package: 5L Tank

CODE	MSRP EUR	MSRP GBP
E828E	€19,23	£17.65



SFFD05L - Fast Dissipating Smoke Fluid

SOUNDSATION SFFD05L Fast Dissipating Fluid is a water-based smoke fluid suitable for all types of smoke machines equipped with a heater block. Its special formulation is designed to provide a well visible smoke soon after it is emitted, but of rapid dispersion after a few seconds. Its stability is good but not very durable. It is a product suitable to create smoke effects that have a good initial persistence, but which require a quick dissipation. The pale green color is pleasant and leaves no traces of any kind on clothes or surfaces while the smoke is white. The scent is neutral and pleasant, and leaves no trace after the dissipation. You can also add one of the many SOUNDSATION fragrances to recreate atmospheres that can range from tropical fruits, flowers and fragrant plants. The SFFD05L is made according to strict production processes and strict controls during all its phases, and meets all the European regulatory requirements. It is available in 5L tanks.

- Dispersion: Quick
- Density: Low
- Color: Pale Green
- For White
- Scent: Neutral
- Package: 5L Tank

CODE	MSRP EUR	MSRP GBP
E827E	€18,39	£16.88



HFWB05L - Medium Density Hazer Fluid

SOUNDSATION HFWB05L Medium Density Hazer Fluid is a water-based fluid suitable for any hazer machine equipped with a heater block. Its density is much lower than a normal smoke liquid; the dispersion is extremely slow with excellent stability. It is a product suitable to create a light but persistent fog able to enhance the light beams of any fixtures and other lighting effects in movie and entertainment contexts. The dark blue color is pleasant and leaves no traces of any kind on clothes or surfaces while the smoke produced is light white. The scent is neutral and pleasant and leaves no trace after the dissolution. You can also add one of the many SOUNDSATION fragrances to recreate atmospheres that can range from tropical fruits, flowers and fragrant plants. The HFWB05L is manufactured according to strict production processes and strict controls during all its phases, and meets all the European regulatory requirements. It is available in 5L tanks.

- Dispersion: Quite Long
- Density: Soft Atmosphere
- Color: Dark Purple
- For Clear White
- Scent: Neutral
- Package: 5L Tank

CODE	MSRP EUR	MSRP GBP
E829E	€19,90	£18.27



BFSD05L - Ready-to-Use Bubble Fluid

SOUNDSATION BFSD05L Bubble Fluid is a water-based fluid with non-ionic surfactant for Bubble Machine, specially designed to produce a large volume of soap bubbles in all those entertainment applications on stages or in clubs, aimed at creating environmental effects with a wonderful atmosphere. It is ready to use, has a good persistence of bubbles and a very high efficiency. The color is neutral and in case of contact with fabrics or other surfaces, it is you just need to wash with water. The perfume is neutral and pleasant and leaves no trace after the dissolution. The BFSD05L is manufactured according to strict production processes and strict controls during all its phases and meets all the European regulatory requirements. It is available in 5-liter tanks.

- Bubble Stability: Good
- Efficiency: Very Good
- Concentration: Ready to Use Liquid
- Neutral / Colorless
- Scent: Neutral
- Package: 5L Tank

CODE	MSRP EUR	MSRP GBP
E830E	€14,67	£13.47



SNFSD05L - Ready-to-Use Snowflake Fluid

SOUNDSATION SNFSD05L Snow Fluid is a water-based fluid and non-ionic surfactants for Snow Machine specially designed to produce a large volume of snowflakes in all of the entertainment applications on stages or in clubs, aimed at creating environmental effects, with a wonderful atmosphere. It is ready to use, has a good persistence of snowflakes and a very high efficiency. The color is neutral and in case of contact with fabrics or other surfaces, it is sufficient to wash with water. The scent is neutral and pleasant and leaves no trace after the dissolution. The SNFSD05L is manufactured according to strict production processes and strict controls during all its phases and meets all the European regulatory requirements. It is available in 5-liter tanks.

- Product Base: Surfactant
- Colour of fluid: Neutral - colourless
- Stability of artificial snow: Good
- Output: Good - efficient and dense snow
- Concentration of product: Ready to use
- Comfort: No smell, Biodegradable

CODE	MSRP EUR	MSRP GBP
E831E	€21,85	£20.06



Blend of essences

Composition designed to be diluted in liquid for artificial smoke and artificial fog liquid, in order to produce perfumed effects in entertainment events, shows, clubs, theaters - For professional use.

- Package: 20ml Bottle
- Dilution: 1x 20ml Bottle in 5l of Smoke/Haze liquid

CODE	MSRP EUR	MSRP GBP	MSRP EUR	MSRP GBP
E832E	FF20ML-APPLE	Blend of Essences - Apple Flavour	€5,01	£4.60
E833E	FF20ML-BANANA	Blend of Essences - Banana Flavour	€5,01	£4.60
E834E	FF20ML-CHERRY	Blend of Essences - Cherry Flavour	€5,01	£4.60
E835E	FF20ML-CHOCOLATE	Blend of Essences - Chocolate Flavour	€5,01	£4.60
E836E	FF20ML-COCONUT	Blend of Essences - Coconut Flavour	€5,01	£4.60
E837E	FF20ML-COFFEE	Blend of Essences - Coffee Flavour	€5,01	£4.60
E838E	FF20ML-COTTONDANDY	Blend of Essences - Cottoncandy Flavour	€5,01	£4.60
E841E	FF20ML-GRAPES	Blend of Essences - Grapes Flavour	€5,01	£4.60
E842E	FF20ML-JASMIN	Blend of Essences - Jasmin Flavour	€5,01	£4.60
E845E	FF20ML-LEMON	Blend of Essences - Lemon Flavour	€5,01	£4.60
E847E	FF20ML-MINT	Blend of Essences - Mint Flavour	€5,01	£4.60
E848E	FF20ML-MUSK	Blend of Essences - Musk Flavour	€5,01	£4.60
E849E	FF20ML-ORANGE	Blend of Essences - Orange Flavour	€5,01	£4.60
E850E	FF20ML-PASSION	Blend of Essences - Passione Flavour	€5,01	£4.60
E851E	FF20ML-PIN	Blend of Essences - Pin Flavour	€5,01	£4.60
E852E	FF20ML-RASPBERRY	Blend of Essences - Raspberry Flavour	€5,01	£4.60
E853E	FF20ML-REENERGY	Blend of Essences - Red Energy Flavour	€5,01	£4.60
E854E	FF20ML-STRAWBERRY	Blend of Essences - Strawberry Flavour	€5,01	£4.60
E855E	FF20ML-TUTTIFRUTTI	Blend of Essences - Tutti Frutti Flavour	€5,01	£4.60
E856E	FF20ML-VANILA	Blend of Essences - Vanila Flavour	€5,01	£4.60
E839E	FF20ML-FLOWER	Blend of Essences - Flower Flavour	€5,01	£4.60
E840E	FF20ML-GRAPEFRUIT	Blend of Essences - Grapefruit Flavour	€5,01	£4.60
E843E	FF20ML-KIWI	Blend of Essences - Kiwi Flavour	€5,01	£4.60
E844E	FF20ML-LAVANDER	Blend of Essences - Lavande Flavour	€5,01	£4.60



LS-200-BR - Set of two lighting stand and 3m truss

The perfect kit for live music, piano bar and DJ sets. It can fit up to 10 pars or effects to a max height of 3,30 meters. Easy to carry, includes mounting accessories.

- Complete set for live music, piano bar and DJ sets
- 3 meters truss to hold up to 10 par or effects
- Pair of stands up to 3,30 mt height
- Easy to carry and setup
- Sturdy steel construction with maximum load capacity of 100 Kg
- Matching hooks: Soundsation SLH001,SLH002,SLH006,SLH009

- Total truss length: 3 meters
- Truss triangular section dimensions: 251x251x251 mm
- Truss Main tubes diameter: 38 mm
- Stand maximum height: 3,3 mt
- Material: black painted steel
- Total weight: 38 Kg

CODE	MSRP EUR	MSRP GBP
D886D	€212,18	£194.78

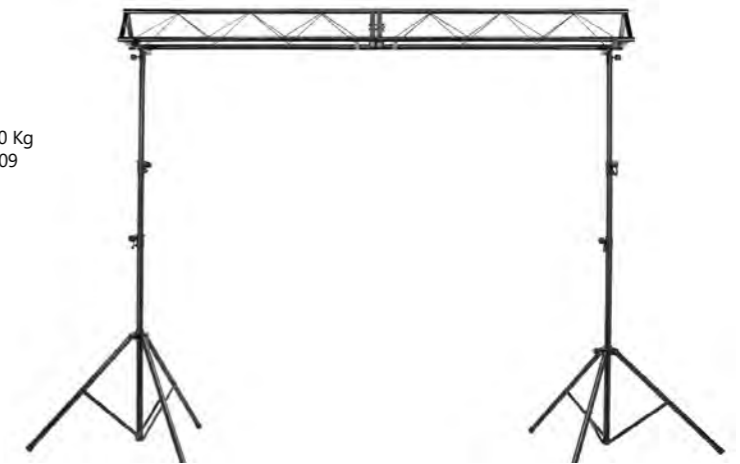

LS-300-TR - Black anodized aluminium structure for lighting

Black anodized aluminium structure for lighting featuring 2 LS-200 professional stand w/T-bar and 2 horizontal bars for 8 par cans. The snap lock holder on height adjustment collar prevents the safety pin from scratching the tubes finish during transportation.

- Height: 1.45 - 3.25mt
- Arm length: 1.5 - 4.0mt
- Arm diameter: 38mm
- Load capacity: 100kg
- Material: anodized aluminium nero
- Snap lock holder on height adjustment collar prevents scratching on the tubes finish during transportation
- Weight: 20kg

CODE	MSRP EUR	MSRP GBP
D725D	€269,14	£247.07

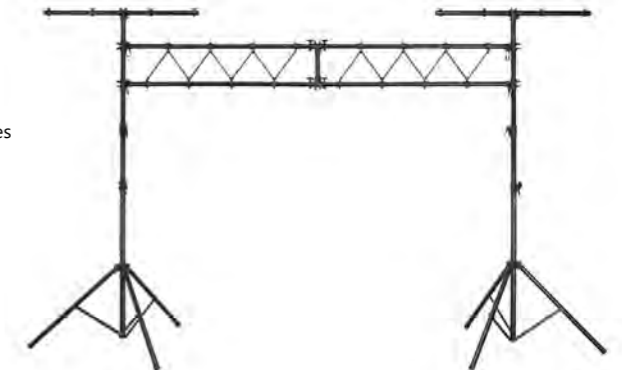

LSA-400 - Wind up heavy duty lighting stand

LSA-400 wind up lighting stand is built to offer stability and reliability. Equipped with windup system. allows to lift up to 85 Kg at 4 meters height. Built in painted black steel, is equipped with security pins. Coming with a rugged packing which can be used for easy carrying.

- Lighting stand for trusses with windup lifting system
- Load capacity of 85Kg max
- 4 Meter maximum height
- Heavy duty construction in black painted steel
- Double braced heavy duty base
- Security pins on the base and on the wind up mechanism
- 35mm pole mount allow to use it as a speaker stand

- Load capacity: 85 Kg
- Height (min-max): 175-400 cm
- Base leg height: 160 cm
- Base diameter: 220 cm
- Weight: 25 kg
- Terminal pole diameter: 35 mm
- Material: steel
- Painting: black

CODE	MSRP EUR	MSRP GBP
D879D	€276,74	£254.05



LS-100 - Steel light stand w/ T-bar

T-bar light stand built in steel to provide maximum reliability and strength, featuring foldable tripod for easy transportation. The snap lock holder on height adjustment collar prevents the safety pin from scratching the tubes finish during transportation.

- Height: 110 - 250 cm
- Arm length: 95 cm
- Arm diameter: 25x25mm
- Load capacity: 30kg
- Material: steel
- Snap lock holder on height adjustment collar prevents scratching on the tubes finish during transportation



CODE	MSRP EUR	MSRP GBP
D723D	€37,78	£34.68

LS-200 - Black anodized aluminium light stand w/ T-bar

Professional T-bar light stand built in anodized aluminium to provide maximum lightness and strength, featuring foldable tripod for easy transportation. The snap lock holder on height adjustment collar prevents the safety pin from scratching the tubes finish during transportation.

- Height: 1.45 - 3.25mt
- Arm length: 1.22mt
- Arm diameter: 38x38mm
- Load capacity: 50kg
- Material: black anodized aluminium
- Snap lock holder on height adjustment collar prevents scratching on the tubes finish during transportation



CODE	MSRP EUR	MSRP GBP
D724D	€78,46	£72.03

LS-10A - Adjustable aluminium stand

Adjustable aluminium stand, ultra light, maximum load 25 kgs. Black finish.

- Aluminium frame (3 parts)
- pole mount diameter: 38mm
- Finish: black
- Max load: 25kgs
- Height: 1.45-3.22m
- Pole mount diameter: 38 mm
- Weight: 5kg



CODE	MSRP EUR	MSRP GBP
I242I	€66,03	£60.62

LSA-300T - Wind up lighting stand with T-BAR

LSA-300T wind up lighting stand is built to offer stability and reliability. Equipped with windup system. allows to lift up to 30 Kg at 3,3 meters height. Including T-BAR to fit up to 4 pars or effects Built in painted black steel.

- Lighting stand for trusses with windup lifting system
- Including T-BAR which can host 4 pars or effects
- Load capacity of 50Kg max
- 3,30 Meter maximum height
- Heavy duty construction in black painted steel
- Double braced heavy duty base
- Equipped with height mark for a quick setup
- Load capacity: 50 Kg
- Height (max): 330 cm
- Base diameter: 220 cm
- T-BAR (H x D x L): 40x20x1200 mm
- Weight: 11 kg
- Material: steel
- Painting: black



CODE	MSRP EUR	MSRP GBP
D880D	€167,87	£154.10

LSA-300 - Wind up lighting stand

LSA-300 wind up lighting stand is built to offer stability and reliability. Equipped with windup system. allows to lift up to 30 Kg at 3,30 meters height. The 35mm pole mount allow to use it a speaker stand. Built in painted black steel.

- Lighting stand for trusses with windup lifting system
- Load capacity of 50Kg max
- 3,30 Meter maximum height
- Heavy duty construction in black painted steel
- Double braced heavy duty base
- Equipped with height mark for a quick setup
- 35mm pole allow to use it as a speaker stand
- Load capacity: 50 Kg
- Height (max): 330 cm
- Base diameter: 220 cm
- Terminal pole diameter: 35 mm
- Weight: 11 kg
- Material: steel
- Painting: black



CODE	MSRP EUR	MSRP GBP
D882D	€150,83	£138.46

LTR-150-STR - Linear 1,5mt truss with triangular section

Perfect to fit pars or other lighting effects, the truss can be attached and lifted with Soundsation LSA series stands thanks to the LTRH-100 adapter (sold separately). Sturdy construction in black painted steel.

- Linear 1,5mt truss with triangular section
- Sturdy construction in in steel with main tubes of
- Used with the adaptor LTRH-100 (not included), can be lifted with Soundsation LSA stands.
- Two trusses can be attached for a total lenght of 3m
- Assembly and par attachment screws included
- Matching hooks: Soundsation SLH001,SLH002,SLH006,SLH009

- Lenght: 1,5 mt
- Triangular section dimensions: 251x251x251 mm
- Main tubes diameter: 38 mm
- Inner tubes diameter: 6 mm



CODE	MSRP EUR	MSRP GBP
D883D	€92,36	£84.79

LST-120 - T-bar for 4 lighting effects or par

Steel T-BAR to 4 pars or lighting effects. Equipped with 36mm pole mount, fits most stands.

- Steel T-BAR
- Fits 4 par or lighting effects
- Lenght: 120 Cm
- Load capacity: 30 Kg
- 36mm pole mount fits most stands

- Dimensions (LxDxH): 120 x 2 x 4 cm
- Pole mount: 36mm
- Load capacity: 30 Kg
- Material: steel



CODE	MSRP EUR	MSRP GBP
D881D	€20,86	£19.15

LTRH-100 - Steel truss adaptor

LTRH-100 is a useful accessory to install trusses on lighting stand with 35 mm pole mount. Compatible with Soundsation LTR-150-STR steel truss. Including mounting screws.

- 35mm pole mount
- Lenght: 20 cm
- Compatible with Soundsation LTR-150-STR truss
- Mounting screws included



CODE	MSRP EUR	MSRP GBP
D884D	€17,24	£15.83

SLH50-500DA

- Width: 50 mm
- Safe working load: 500 kg (TÜV Certified)
- Fit tube Dimeter: Ø38-51 mm
- Material: Aluminum Alloy 6061-T6
- Accessories: M12 eyelet bolt, Flat washer & Wing nut
- Surface Treatment: Polishing
- Color: Aluminum
- Notes: Free swivel movement in 360°



CODE	MSRP EUR	MSRP GBP
E510E	€35,31	£32.41

SQCLH50-150A

- Width: 30 mm
- Safe working load: 150 kg (TÜV Certified)
- Fit tube Dimeter: Ø38-51 mm
- Material: Aluminum Alloy 6061-T6
- Accessories: 1/2" eyelet bolt (12.7mm)
- Surface Treatment: Polishing
- Color: Aluminum



CODE	MSRP EUR	MSRP GBP
E512E	€20,18	£18.53

SLH50-500A

- Width: 50 mm
- Safe working load: 500 kg (TÜV Certified)
- Fit tube Dimeter: Ø38-51 mm
- Material: Aluminum Alloy 6061-T6
- Accessories: M12 eyelet bolt, Flat washer & Wing nut
- Surface Treatment: Polishing
- Color: Aluminum



CODE	MSRP EUR	MSRP GBP
E508E	€17,49	£16.06

SLH10-60A

- Thickness: 3 mm
- Safe working load: 60 kg
- Fit tube Dimeter: Ø30-51 mm
- Material: Steel
- Accessories: M8x60 Plastic bolt, M8x70 hexagon bolt, Double flat washer, Double spring washer, Double hexagon nut
- Surface Treatment: Baking paint
- Color: Black



CODE	MSRP EUR	MSRP GBP
E518E	€5,72	£5.25

SLH50-300DA

- Width: 30 mm
- Safe working load: 300 kg (TÜV Certified)
- Fit tube Dimeter: Ø38-51 mm
- Material: Aluminum Alloy 6061-T6
- Accessories: M12 eyelet bolt, Flat washer & Wing nut
- Surface Treatment: Polishing
- Color: Aluminum
- Notes: Free swivel movement in 360°



CODE	MSRP EUR	MSRP GBP
E511E	€26,90	£24.69

SQLH50-150A

- Width: 28 mm
- Safe working load: 150 kg (TÜV Certified)
- Fit tube Dimeter: Ø48-51 mm
- Material: Aluminum Alloy 6061-T6
- Accessories: 1/2" eyelet bolt (12.7mm), Flat washer, Die casting "S" knob
- Surface Treatment: Polishing
- Color: Aluminum



CODE	MSRP EUR	MSRP GBP
E513E	€19,51	£17.91

SLH30-200A

- Safe working load: 200 kg
- Fit tube Dimeter: Ø25-51 mm
- Material: Aluminum
- Accessories: M10x75 wing bolt with a claw
- Surface Treatment: Polishing
- Color: Aluminum



CODE	MSRP EUR	MSRP GBP
E514E	€11,43	£10.49

SLH010

- Locking Type: Screw
- SWL (Safe Working Load): 80 kg
- Pipe Diameter: From 40 to 60 mm (from 1.57 to 2.36 in)



CODE	MSRP EUR	MSRP GBP
L182L	€17,95	£16.48

SLH006

- Locking Type: Screw
- SWL (Safe Working Load): 35 kg
- Pipe Diameter: From 32 mm (1.26") to 42 mm (1.65")



CODE	MSRP EUR	MSRP GBP
L181L	€17,95	£16.48

General sales terms

Scope of application: unless differently provided by written agreement between the Parties, these general terms and conditions of sale shall govern any and all offers, proposals, purchase orders and contracts entered into by FRENEXPORT S.p.A. (hereinafter “FRENEXPORT”) with the Customer. General terms and conditions of purchase issued by the Customer shall not be valid and enforceable between the Parties.

Offers - Orders - Order confirmations: offers made by FRENEXPORT shall, unless otherwise specified in writing in the same, be valid for 30 days from the date of transmission to Customer. All purchase orders from Customers (hereinafter “Orders”) shall be formalized in writing and sent by fax or email to FRENEXPORT head office. For Orders for less than £500.00, FRENEXPORT shall charge Customer with the additional sum of £10.00 as administrative charges. The contract shall be deemed entered into between the Parties as of the date of receipt by Customer of the written Order Confirmation by FRENEXPORT.

Order Cancellations -In exceptional circumstances and solely at the discretion of FRENEXPORT, cancellations may be accepted.

Verbal cancellations will only be valid if they are confirmed in writing by the customer and sent to FRENEXPORT by recorded delivery post, facsimile transmission or e-mail.

Special Orders in specific sizes and or finishes will be supplied by FRENEXPORT wherever possible, subject to an acceptance by the customs that the order cannot be cancelled, or the goods returned and all sizes and specifications are provided to FRENEXPORT by the customer in writing. In certain instances, and before acceptance of such special orders, FRENEXPORT will require a deposit of 50% of the total purchase price.

Documents - Price List: all information and data indicated in FRENEXPORT’s catalogues, leaflets, price lists and other informative documentation (hereinafter “Documentation”) shall be deemed purely indicative and may be subject to change at any time and prior to further notice. Customer is expressly forbidden to reproduce the Documentation by any means whatsoever and disclose its contents to any third party.

Delivery: Terms of delivery, where agreed, are purely indicative. Any delays in delivery shall not entitle Customer to termination of contract and to compensation for any direct or indirect damage, except in case of malice or gross negligence by FRENEXPORT, holding the obligation towards the client to pack the goods adequately and to protect them in such manner that they are able to reach the destination in good condition using standard transportation. The client is responsible for adequate transport insurance. Products will be delivered Ex works (EXW) our warehouse in Porto Recanati (Italy), and will be considered as delivered when materially collected by the Customer or a carrier. Delivery, if requested, will be made on behalf of the Customer and at Customer’s risk and cost.

FRENEXPORT shall have no liability whatsoever for any damage to or losses of Products occurring during transport, therefore the related risk shall remain exclusively with Customer. Customer shall, on pain of forfeiture, verify the integrity of packaging and check the quantity of Products upon their receipt, making the appropriate written reserves with the carrier and promptly notifying FRENEXPORT.

Prices - terms of payment: The Prices of the products and services shall be those stated in the corresponding Order Confirmation. Prices are indicated net of: (i) VAT and any other applicable tax; (ii) packaging expenses; (iii) shipping and transport costs.

Payments may be made by credit titles only if this mode of payment has been specifically agreed, and acceptance of said credit titles by FRENEXPORT shall always be deemed subject to final payment. Any covenant to the contrary is expressly excluded.

Customer may in no event and on no account delay, suspend or omit any payments due. Any claim or title Customer may have shall be enforced by a separate action, it being expressly understood that Customer shall not be entitled to set off any sums due by the same against any of its credits or claims.

In case of failure by Customer to pay any amount due by the same within the agreed deadlines, FRENEXPORT shall be entitled to:

- Suspend performance of the corresponding contract and/or any other contracts in place with Customer, including any warranty obligations;
- Immediate payment of all sums payable by Customer, on any ground, even under other contracts, all such sums becoming immediately due;
- A refund of the expenses sustained to recover the sums not promptly paid by Customer;
- Compensation for any further damage.

In any case, any and all sums payable by Customer shall become immediately due whenever one of the following circumstances occurs:

- Customer becomes insolvent;
- The guarantees provided are diminished;
- The promised guarantees are not provided.

Where Customer has several debts to FRENEXPORT, the latter may decide from time to time to which debt any payment by Customer is to be allocated.

Title to Goods: Property in the goods and services shall not pass to Customer until Customer has discharged all outstanding indebtedness to FRENEXPORT whatsoever. Customer will store the goods supplied by FRENEXPORT in a way which makes them clearly identifiable as FRENEXPORT’s property or maintains records of goods owned by FRENEXPORT and shall identify them to FRENEXPORT on demand. Failing such identification, all goods supplied by FRENEXPORT in Customer’s possession shall be deemed to belong to FRENEXPORT. Any products of identical type supplied by the FRENEXPORT to Customer over a period of time and on a number of different invoices, any stock remaining unsold at any time will be taken as relating to that supplied on the most recent invoice(s). If unpaid for goods are sold to a third party by Customer, then title to the goods remains with FRENEXPORT until such time as Customer pays FRENEXPORT for such goods.

If Customer fails to make payments when due, enters into bankruptcy, liquidation, has a receiver or manager appointed over any of its assets or becomes insolvent, or if FRENEXPORT has a reasonable cause to believe that any of these events may occur, FRENEXPORT shall have the right, without prejudice to any other remedy of FRENEXPORT to repossess the goods without prior notice and the customer will permit FRENEXPORT, or its agents to enter any premises for the purpose of such possession.

Warranty and Return: Warranty against defects shall have a maximum validity of one year from the date of delivery of the products.

Any apparent defects of the products shall be reported by Customer in writing, on pain of forfeiture, within eight (8) days of receipt of the products. Any hidden defects of the products shall be reported by Customer in writing, on pain of forfeiture, within eight (8) days of their discovery.

FRENEXPORT’s warranty against defects shall no longer be effective whenever:

- Customer or any third party make any repair or change to the products without the prior written consent of the latter;
- Customer or any third party alter or misuse the products;
- Customer does not allow FRENEXPORT or its authorized agents to carry out any and all reasonable control on the products declared to be defective;
- Customer fails to promptly return the defective products to FRENEXPORT, where so required by the latter.

Subject to FRENEXPORT prior written authorization, defective or non-complying products may be returned by Customer who shall send them to FRENEXPORT designated country Service Centre. In any such event, returned products shall be accompanied by the return authorization form duly issued by FRENEXPORT or his designated agent as well as by a specific description of the products and of the defects encountered in the same, with the specification of the indicative number of products as well as the date of the relative sale invoice.

If, upon due verification of the products returned, FRENEXPORT establishes the existence of the alleged defects and applicability of the warranty, FRENEXPORT, at its sole discretion shall either repair the products at its own charge and expense; or replace the defective products. It is expressly understood that repair or substitution of defective products shall be the sole remedies available in relation to the warranty obligations provided above.

